



USER MANUAL

INDUSTRY Modbus

Wind Sensors



Contents

1	Warranty	3
2	Benefits of the INDUSTRY wind sensors	3
3	Initial operation	3
4	Selecting the place of installation	3
5	Principles of installation	4
6	Setting up the north direction for the wind vane	5
7	Electrical connections	5
8	Heating	6
9	Maintenance	6
10	Wiring diagram	7
11	Dimensioned drawings	8
12	Modbus data protocols	9
12.1	General	9
12.2	Data encoding	9
12.3	Standard configuration - Default	9
12.4	Available Modbus commands	10
12.5	Instantaneous values / realtime values (Input Register)	10
12.6	Period data - Average, maximum and minimum (Input Register)	10
12.7	Descriptive sensor parameter registers (Holding Register)	11
12.8	Configuration registers (Holding Register)	12
13	Autoconfiguration	12
14	Disposal	12
15	Technical data	13

1 Warranty

Please note the loss of warranty and non-liability by unauthorized manipulation of the system. You need a written permission of the LAMBRECHT meteo GmbH for changes of system components. These activities must be operated by a qualified technician.

The warranty does not cover:

1. Mechanical damages caused by external impacts (e. g. icefall, rockfall, vandalism).
2. Impacts or damages caused by over-voltages or electromagnetic fields which are beyond the standards and specifications in the technical data.
3. Damages caused by improper handling, e. g. by wrong tools, incorrect installation, incorrect electrical installation (false polarity) etc.
4. Damages which are caused by using the device beyond the specified operation conditions.

2 Benefits of the INDUSTRY wind sensors

The INDUSTRY Modbus wind sensors are very economical to purchase. The sensors also impress with their high accuracy, simple mounting principles and seawater-resistant, very robust materials. The thermal decoupling of the housing shaft enables optimum heating of the sensor head and minimum power requirement of the system.

- Proven sensor technology
- Very good starting values
- Large measuring and temperature application ranges
- Easy mast mounting
- Optimal heating concept

3 Initial operation

Wind can be represented by a vector quantity. A complete description requires the specification of speed and direction. Both components are subject to spatial and temporal fluctuations so that, strictly speaking, they only apply to the location where the measuring device is installed. The choice of installation location is therefore particularly important.

4 Selecting the place of installation

Generally, wind measuring instruments should not measure the specific wind conditions of a limited area, but indicate the typical wind conditions of a wider area. The values measured at different places must be comparable. Thus, when installing the sensor you should make sure the place of installation is not under the lee of great obstacles. The distance between the obstacles and the sensor should be 10 times the height of the obstacles (this corresponds to the definition of an undisturbed terrain).

If there is no *undisturbed terrain*, the sensor must be set up at a height that exceeds the height of the obstacle by at least 5 m.

If the sensor must be installed on a roof top the place of installation must be in the middle of the roof to avoid predominant wind directions.

If you want to measure both wind direction and wind speed, install the sensors at the same measuring point, if possible, and make sure to avoid any mutual influence of the sensors. A wind sensor pair easily meets this requirement since the sensors are set up side by side. Their horizontal distance should be approximately 1.5 m. The two sensors must be staggered vertically so that the lower edge of the upper wind speed sensor is 0.1 to 0.5 m above the upper edge of the lower wind direction sensor.

5 Principles of installation



Attention! Because the installation takes place in a dangerous height, the assembly personal must follow the rules for prevention of accidents.

I. TRAVERSE WITH BORE (E.G. ID 32.14627.010000)

Material thickness for installation of the sensor between the nuts may be max. 10 mm.

1. The sensor is led without cable into the bore and fastened by the opposite side with the loose nut.
2. Attach the sensor with the flat side of detached nut from the lower side. Tighten with a suitable tool (wrench size 36), until a twisting safety of the sensor aligned to the north is given.

II. MAST OR PIPE MOUNTING



Make sure the device is easily accessible so that you can set up the north direction for the wind direction sensor and perform any maintenance work. To reach the sensors use a ladder of the appropriate length or a telescoping working platform of the appropriate height.



Ladders or other climbing aids must be in perfect working order and guarantee a secure hold! Observe the accident prevention regulations of the employers' liability insurance associations.

Mount the sensors at the top of grounded tube with an outer diameter of 48-50 mm. The mast adapter (see accessories) is obligatory.

1. Remove both thread nut from the sensor.
2. The sensor is inserted without cable into the bore (\varnothing 30 mm) of the adapter and locked from the opposite side with a loose nut in the direction of the adapter.
3. Finally we recommend to lock the second nut with its plane side ahead against the first nut (see drawing).

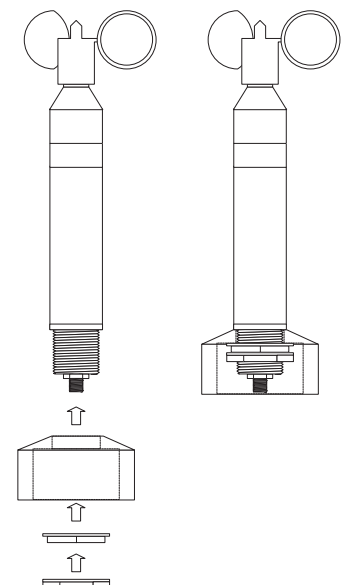

If wind speed and wind direction are measured at the same time, the measurement generally takes place not only at the top of a mast but also at the ends of a cross arm. The arms must stay torsion-free and vibration-proof even at high wind speeds and they must be accessible for you to perform mounting and maintenance work.



When installing the connecting cables make sure not to excessively shorten the cable leading to the connector in the lower part of the sensor casing so that you can later maintain or dismounting the sensor. Also place a cable loop under the sensor as a water trap.

Tip: Mount the sensors on the ground on the traverse and align the wind vane parallel to the traverse. Then climb up to align the sensors on the traverse with the help of a partner on the ground.

6 Setting up the north direction for the wind vane

For wind direction measurements the north mark on the sensor must be aligned with the geographical north direction. You have to turn the marking exactly over the marking at the sensor shaft. When you have aligned the marks, you may fix the wind vane with e.g. a piece of adhesive tape. When you have fixed the wind vane this way you can locate the reference point by aiming at it over the axis. Now you must turn the sensor casing on the mounting tube until the tip of the wind vane points to the reference point in the north. To set up the sensor's north orientation select a landmark which is as far as possible up north with regard to the final position of the wind direction sensor. The reference point can be selected using a topographical map (1:25000). The exact position of the reference point is determined using an amplitude compass that can be adjusted horizontally on a stand.



Please make sure there is no magnetic deviation of the compass.

Once the wind direction sensor is aligned, you can mount it as described under "Mounting". The adhesive strips must be removed. A functional test on three directions offset by 90° is recommended. If the local conditions do not allow the reference point to be set up in the north direction, the procedure can be applied analogously to a southern reference point. Note that the north mark on the sensor then does not point to the reference point, but in the opposite direction.

7 Electrical connections

INDUSTRY wind sensors are connected to a data measuring system via the open cable end. The sensors have a cable plug-plug connection to the cable. The connecting cable is suitably led along the mast between the data evaluation device (indicating instrument or data acquisition system) and the sensor. The cable must be fastened using appropriate cable ties (their length depends on the mast diameter).



Tip: Lead the cable in a wide curve from the mast to the bottom of the casing so that you can later easily dismount the cable.

Please note that the cable on the data processing side is protected against moisture, e.g. by using suitable cable glands. If the mast is prepared accordingly, the connection cable can also be laid completely in the pipe sections of a mast.



To reduce the risk of inductive interference the sensor must be properly grounded (screening on both sides).

8 Heating

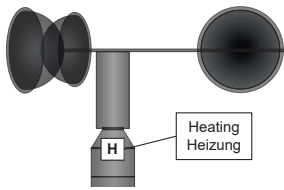

The sensor has an electronically controlled 18 watt heating system in the sensor head. The heating is supplied together with the electronics of the sensor. The heating prevents the moving parts from blocking under most climatic conditions (see illustration). The cup rotor or the vane are not heated. If icing or ice formation forms on the movable sensor element, the function is restricted for the duration of the icing.

9 Maintenance

The design of the sensors ensures maintenance-free operation over a long period of time. We recommend a regular visual inspection of the alignment of the wind direction sensor and calibration of both sensor types every two years. If problems occur during the checks that you cannot solve, please contact the LAMBRECHT meteo service at:

Tel: +49-(0)551-4958-0

Email: support@lambrecht.net

10 Wiring diagram

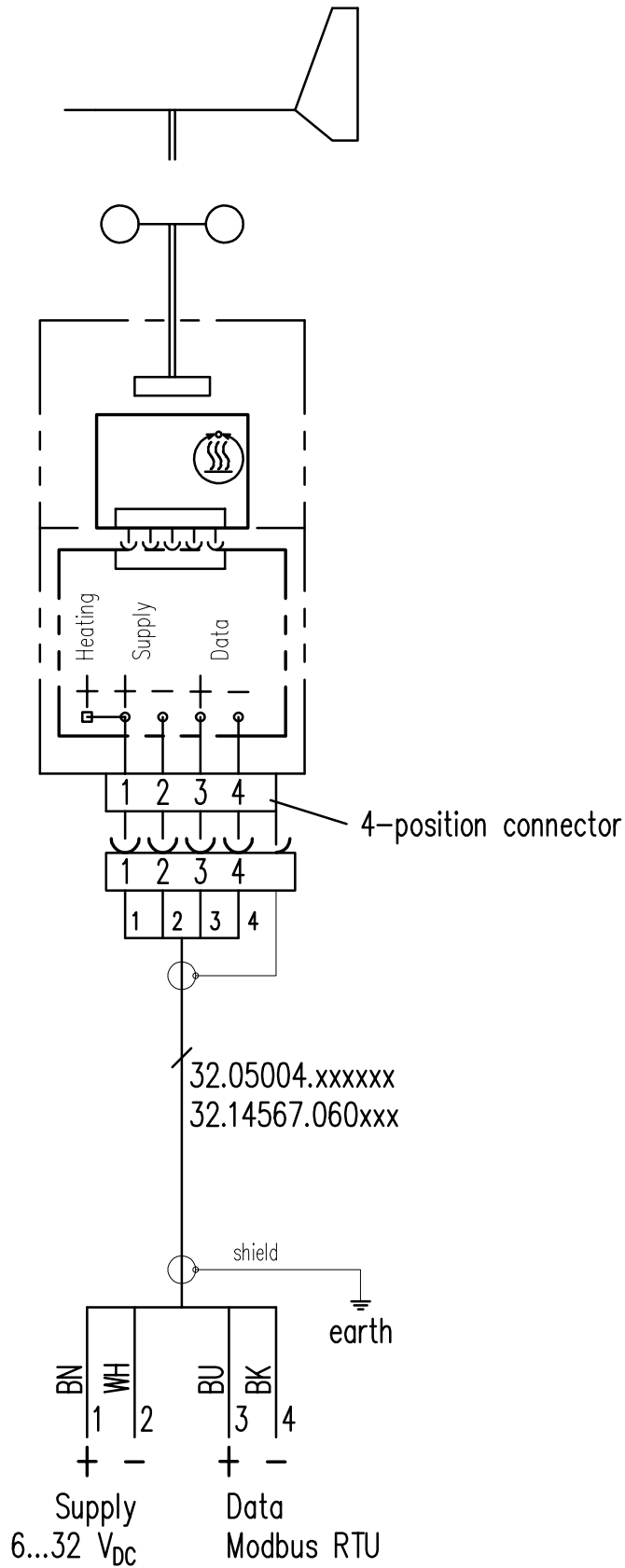

11 Dimensioned drawings

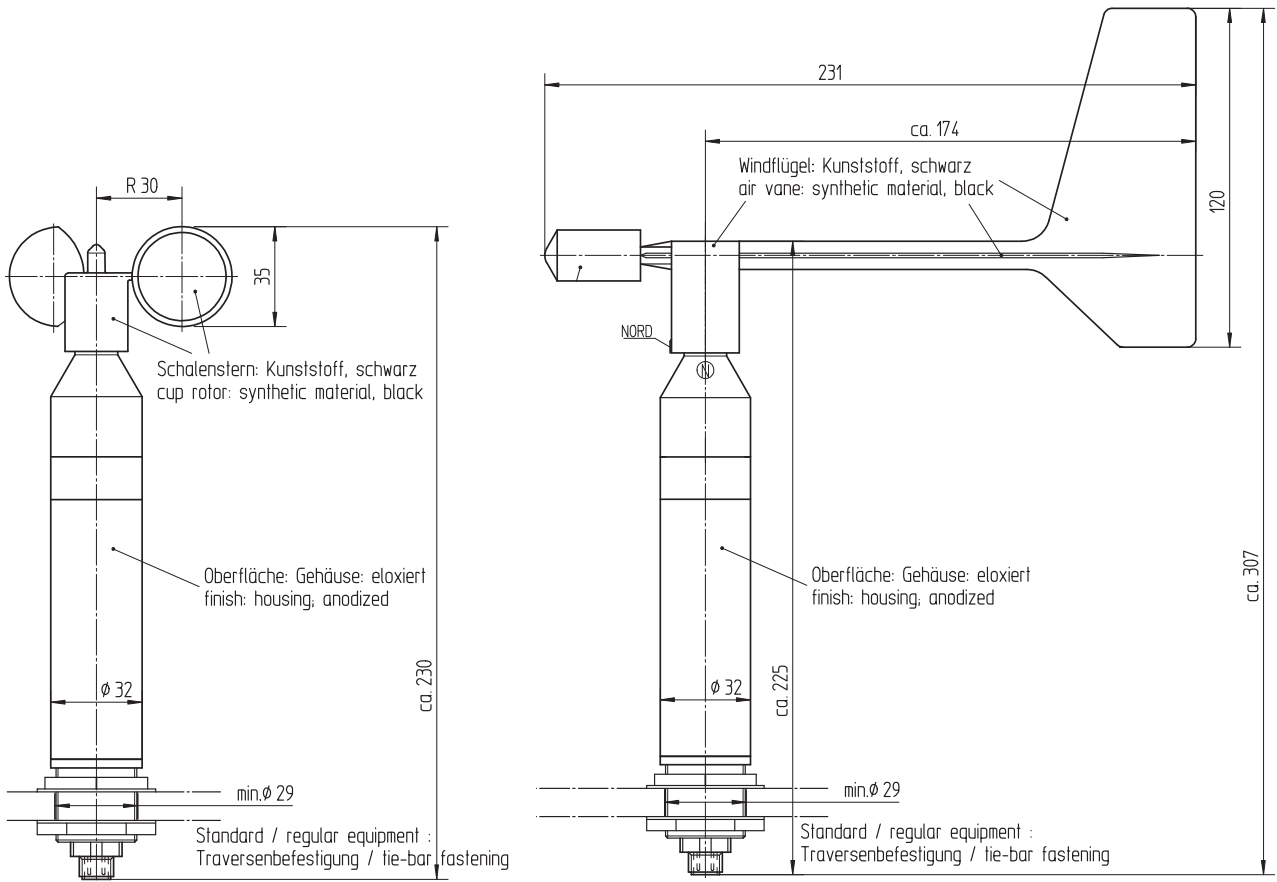

Accessory (optional):

Mast adapter

ID 32.14567.006000

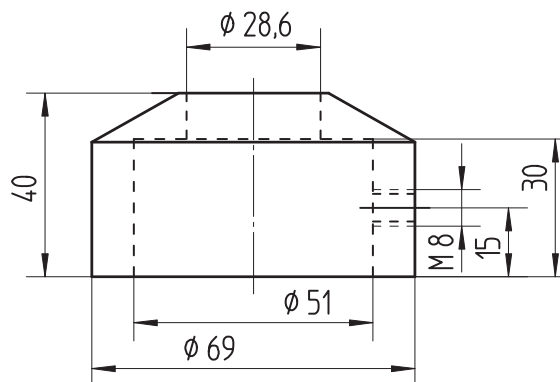

12 Modbus data protocols

12.1 General

The LAMBRECHT meteo Modbus sensors follow the specification of the Modbus organization: "MODBUS APPLICATION PROTOCOL SPECIFICATION V1.1b3" (see www.modbus.org).

12.2 Data encoding

MODBUS uses the "Big-Endian" format for addresses and data. This means that if a value is transmitted with a number format which is larger than a single byte, that the "most significant byte" is sent first.

Example Big-Endian:

Register size value 16 - bits

0x1234 is transmitted in the sequence: 0x12 0x34

To obtain the real measuring value, divide the received register value by the divisor.

Values of -9999 indicate an internal sensor error.

12.3 Standard configuration - Default

Baud rate: 19200 Baud
 Byte frame: 8E1 (1 start bit, 8 data bits, 1 parity bit (even parity), 1 stop bit)
 RTU Sensor address: (1) Wind speed sensor
 (2) Wind direction sensor

DEFAULT ADDRESSES OF THE LAMBRECHT SENSORS

Address	Sensor
1	Wind speed
2	Wind direction
3	Precipitation rain[e]
4	THP
5	EOLOS IND; u[sonic]WS6
6	com[b]
7	PREOS
8	ARCO
9	u[sonic]
10	Pyranometer 2nd Class
11	Secondary standard Pyranometer
12	PT100 to Modbus converter (temperature)
13	u[sonic]WS7

12.4 Available Modbus commands

The LAMBRECHT Modbus sensors support the following commands:

- “Read Holding Register” command: 0x03 (descriptive sensor data registers)
- “Read Input Register” command: 0x04 (measured values registers)
(every measured value is to be requested individually)
- “Write Multiple Register” command: 0x10 (write to configuration registers)

12.5 Instantaneous values / realtime values (Input Register)

The following measured values are provided:

Register address	Parameter name	Unit	Divisor	Quantity of registers	Access type
30001	Wind speed	m/s	10	1	Read only
30201	Wind direction	°	10	1	Read only

Example: Retrieve wind speed

0D 04 75 31 00 01 7A C5 0D 04 02 00 1F E8 F9

LEN 6	Transmission Query =>	Source Master	Dest Slave 13	Function Read Input Register (4)	Func Desk Address=30001, Quantity of Register=1	Checksum OK:C57A
LEN 5	Transmission Response <=	Source Slave 13	Dest Master	Function Read Input Register (4)	Func Desk Byte count=2	Data 00 1F Checksum OK:F9E8

12.6 Period data - Average, maximum and minimum (Input Register)

Register	Parameter name	Unit	Divisor	Quantity of registers	Access type
30002	Wind speed average	m/s	10	1	Read only
30003	Wind speed maximum	m/s	10	1	Read only
30004	Wind speed minimum	m/s	10	1	Read only
30202	Wind direction average	°	10	1	Read only
30203	Wind direction maximum	°	10	1	Read only
30204	Wind direction minimum	°	10	1	Read only

The data are valid for the period between the current request and the previous request. The maximum range of a period is 1 hour. Recalling the average value of a minimum, maximum and average group will erase the appropriate registers.

Retrieve the values of a group in the sequence minimum, maximum, average.

Use command: 0x03

Example: Retrieve wind speed (min. max. avr.) and delete the register content

01	04	75	34	00	01	6A	08	01	04	02	00	00	B9	30	01
04	75	33	00	01	DB	C9	01	04	02	00	D6	38	AE	01	04
75	32	00	01	8A	09	01	04	02	00	14	B9	3F			

LEN 6	Transmission Query =>	Source Master	Dest Slave 1	Function Read Input Register (4)	Func Desk Address=30004, Quantity of Register=1	Checksum OK:86A
LEN 5	Transmission Response <=	Source Slave 1	Dest Master	Function Read Input Register (4)	Func Desk Byte count=2	Data 00 00 Checksum OK:30B9
LEN 6	Transmission Query =>	Source Master	Dest Slave 1	Function Read Input Register (4)	Func Desk Address=30003, Quantity of Register=1	Checksum OK:C9DB
LEN 5	Transmission Response <=	Source Slave 1	Dest Master	Function Read Input Register (4)	Func Desk Byte count=2	Data 00 D6 Checksum OK:AE38
LEN 6	Transmission Query =>	Source Master	Dest Slave 1	Function Read Input Register (4)	Func Desk Address=30002, Quantity of Register=1	Checksum OK:98A
LEN 5	Transmission Response <=	Source Slave 1	Dest Master	Function Read Input Register (4)	Func Desk Byte count=2	Data 00 14 Checksum OK:3FB9

12.7 Descriptive sensor parameter registers (Holding Register)

Register	Parameter name	Quantity of registers	Remark	Access type
40050	Device identification number (15 characters)	8 (2 characters in each register)	The returned data are in form of a 16 byte null terminated string	Read only
40100	Serial number (11 characters)	6 (2 characters in each register)	The returned data are in form of a 12 byte null terminated string	Read only
40150	Firmware version (up to 25 characters)	13 (2 characters in each register)	The returned data are in form of a 26 byte null terminated string	Read only

Example: Retrieve the device identification number (the identification number shown in the example is sensor-dependent. It is only used here for demonstration purposes)

0D	03	9C	72	00	08	CA	8B	0D	03	10	30	30	2E	31	36	□□□□□□□□□□□□□□
34	38	30	2E	30	30	31	31	33	30	00	E8	6B				00.16480.000130□□□□

LEN 6	Transmission Query =>	Source Master	Dest Slave 13	Function Read Holding Register (3)	Func Desk Address=40050, Quantity of Register=8	Checksum OK:8BCA
LEN 19	Transmission Response <=	Source Slave 13	Dest Master	Function Read Holding Register (3)	Func Desk Byte count=16	Data 30 30 2E 31 36 34 38 30 2E 30 30 31 31 33 30 00 Checksum OK:6BE8

12.8 Configuration registers (Holding Register)

Register	Parameter name	Allowed values	Quantity of registers	Access type
40001	Modbus device address		1	Write only
40200	Baud rate	96 = 9600 192 = 19200 384 = 38400	1	Write only
40201	Parity	1 = even 0 = none	1	Write only

The device must be restarted after each change of a setting!

Example: Change the RTU address from 4 to 1

05	10	9C	41	00	01	02	00	01	06	48	05	10	9C	41	00
01	7E	09													

LEN 9	Transmission Query =>	Source Master	Dest Slave 5	Function Write Multiple Register (16)	Func Desk Address=40001, Quantity=1	Byte count 2	Register values 00 01	Checksum OK:4806
LEN 6	Transmission Response <=	Source Slave 5	Dest Master	Function Write Multiple Register (16)	Func Desk Address=40001, Quantity=1	Checksum OK:097E		

13 Autoconfiguration

All LAMBRECHT Modbus sensors offer experienced users the option of implementing an auto-configuration in their Modbus master based on additional information stored in the sensor. The necessary information can be found in the document “Lambrecht_Modbus_Autoconfiguration”.

14 Disposal

LAMBRECHT meteo GmbH is listed and registered at the Stiftung Elektro-Altgeräte Register ear under:

WEEE-Reg.-Nr. DE 45445814

In the category of monitoring and control instruments, device type: “Monitoring and control instruments for exclusively commercial use”.

Within the EU



The device has to be disposed according to the European Directives 2002/96/EC and 2003/108/EC (Waste Electrical and Electronic Equipment). Do not dispose the old device in the household waste! For an environmentally friendly recycling and disposal of your old device, contact a certified disposal company for electronic waste.

Outside the EU

Please follow the regulations in your country regarding the appropriate disposal of waste electronic equipment.

15 Technical data

Measuring principle	Hall Sensor Array, non-contact
Range of application	temperatures -30...+70 °C (heated) *; wind speed 0...60 m/s
Heating	18 W heating; electronically controlled The heating within the sensor head prevents blocking of the moving parts under most climatological conditions.
Supply voltage	24 VDC (6...32 VDC)
Current consumption	max. 800 mA at 24 VDC and max. heating; 13 mA at 24 VDC and inactive heating (Note: The heating can be deactivated via software tool. This allows the current consumption to be reduced to 8.5 mA at 24 VDC.)
Housing	seawater-resistant Aluminium; anodized; IP 55; shaft-Ø 32 mm; for mounting-bore Ø 30 mm at max. 10 mm material thickness
Dimensions	see dimensioned drawings
Included in delivery	1 sensor (without cable)
For connection to (not included in delivery)	LAMBRECHT data processing systems; power supplies; user specific evaluation systems
Accessory (please order separately)	ID 32.14567.060000 Sensor cable with M12 plug connector, 4-pin; length: 12 m

Parameters	Wind direction sensor ID 00.14567.110030	Wind speed sensor ID 00.14577.110030
Measuring elements	wind vane, stably; fibre-reinforced plastics	3-armed cup rotor; fail-safe plastics
Measuring ranges	0...360°	0.7...50 m/s
Accuracy	± 2°	0.5 m/s at 0.7...5 m/s and 2 % FS at 5.02...50 m/s
Resolution	1°	< 0.02 m/s
Starting value	< 0.7 m/s	< 0.7 m/s
Interface	RS485	RS485
Protocol	Modbus RTU	Modbus RTU
Weight	0.35 kg	0.25 kg
Measured values	instantaneous value; average value; max. value of the average value; min. value of the average value	



*) Note: In the event of possible icing and ice formation on the moving sensor element, the function is limited for the duration of the icing.

We offer specially heated sensors for use in locations with acute icing hazards.