

USER MANUAL

PRO-Modbus

Wind Sensors



Contents

1	PRO-Modbus overview	3
2	Warranty	3
3	Initial operation	4
4	Maintenance	5
5	Principles of installation	5
6	Setting up the north direction for the wind direction sensor	6
7	Electrical connection	6
8	Heating	6
9	Wiring diagram	7
10	Dimensioned drawings	8
11	Modbus protocol	9
11.1	Data encoding	9
11.2	Device address	9
11.3	Standard configuration - Default	9
11.4	Modbus command set	10
11.5	Measured value and parameter registers	10
11.6	Sensor parameters / Configuration parameters	11
11.7	Mapping register for autoconfiguration	11
11.8	Autoconfiguration	11
11.9	Mapping register	13
12	Disposal	13
13	Technical data - Cable	13
14	Technical data - Sensors	14

1 PRO-Modbus overview

BENEFITS

- Wear-free, precise data acquisition
- High reliability and longevity
- Cup rotor made of seawater-resistant aluminium
- For highest capacity
- Simple installation for mast, flange and bore
- Practical cable plug connection

FEATURES

- Outstanding protection against electrostatic discharge for operation in lightning-prone regions
- Wide range of operating for all-year application in most climatic zones due to integrated, regulated heating
- Especially robust due to reinforced axis
- Very wide measuring range
- Low starting values of
- High resolution of measuring values
- Very low needs of maintenance

STANDARDS

- EMC acc. to EN 61000-6-2, EN 61000-6-4,
- EN 61000-4-2, -3, -4, -5, -6, -11,
- Namur NE-21
- VDE 0100
- WMO No. 8
- VDI 3786 part 2

2 Warranty

Please note the loss of warranty and non-liability by unauthorized manipulation of the system. You need a written permission of the LAMBRECHT meteo GmbH for changes of system components. These activities must be operated by a qualified technician.

The warranty does not cover:

1. Mechanical damages caused by external impacts (e. g. icefall, rockfall, vandalism).
2. Impacts or damages caused by over-voltages or electromagnetic fields which are beyond the standards and specifications in the technical data.
3. Damages caused by improper handling, e. g. by wrong tools, incorrect installation, incorrect electrical installation (false polarity) etc.
4. Damages which are caused by using the device beyond the specified operation conditions.

3 Initial operation

The wind can be represented by a vector quantity. For a complete description of the wind it is necessary to specify its speed and direction. The two components are subject to spatial and temporal variations; thus, strictly speaking, they are valid only for the site where the measuring instrument is put up. We therefore recommend to select the place of installation very carefully.

SELECTING THE PLACE OF INSTALLATION

Generally, wind measuring instruments should not measure the specific wind conditions of a limited area, but indicate the typical wind conditions of a wider area. The values measured at different places must be comparable. Thus, when installing the sensor you should make sure the place of installation is not under the lee of great obstacles. The distance between the obstacles and the sensor should be 10 times the height of the obstacles (this corresponds to the definition of an undisturbed terrain).

If an undisturbed terrain of this kind does not exist the sensor must be put up at a height of at least 5 m above the obstacle height. If the sensor must be installed on a roof top the place of installation must be in the middle of the roof to avoid predominant wind directions.

If you want to measure both wind direction and wind speed, install the sensors at the same measuring point, if possible, and make sure to avoid any mutual influence of the sensors. A wind sensor pair easily meets this requirement since the sensors are set up side by side. Their horizontal distance should be approximately 1.5 m. The two sensors must be staggered vertically so that the lower edge of the upper wind speed sensor is 0.1 to 0.5 m above the upper edge of the lower wind direction sensor.

MOUNTING OF THE CUP ROTOR AND THE WIND VANE AT THE SENSOR

The bores at the cup rotor and the wind vane are attached in such a way that they can only be installed in a certain clear position. All 3 screws must be used to fasten the cup rotor resp. the wind vane. Thus the correct direction of rotation is guaranteed. The necessary wrench is included in delivery.

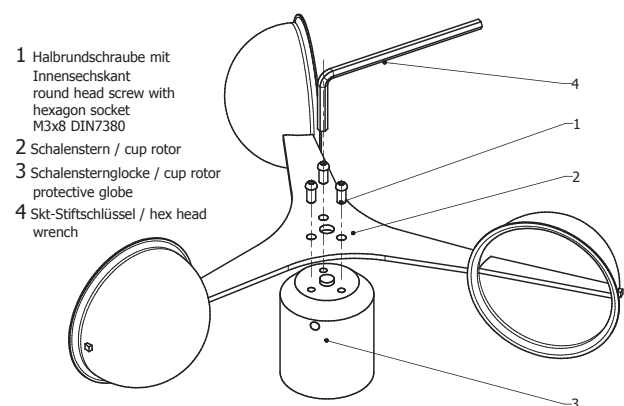
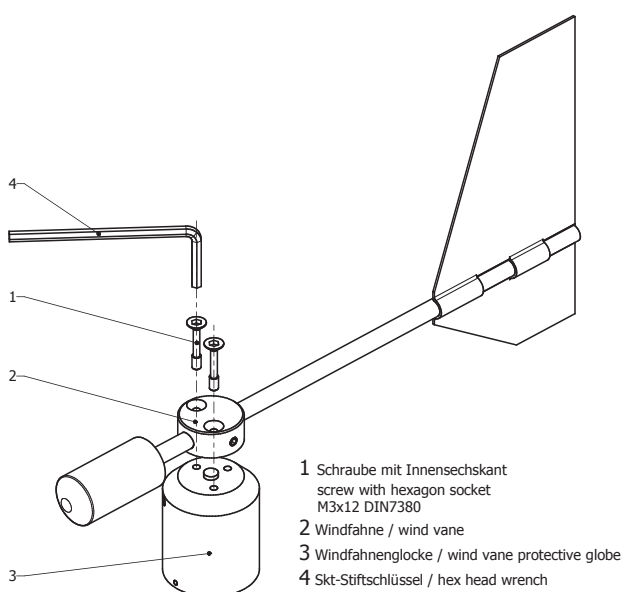

4 Maintenance

The sensor design permits long periods of maintenance-free operation. We recommend a regular visual verification and functional test of the wind sensors as well as a sensor calibration of both sensor types at intervals of 2 years.

With problems, which you cannot solve, do not hesitate to contact our LAMBRECHT meteo service under:

Tel: +49-(0)551-4958-0

Email: support@lambrecht.net

5 Principles of installation



Because the installation take place in a dangerous height, the assembly personal must follow the rules for prevention of accidents.

I. TRAVERSE WITH SLOTTED BORES

(ID 32.14567.010000)

At the traverse at each end are bores with a slot and with a \varnothing 30 mm.

1. Remove the nut from the sensor.
2. Put a sensor with assembled cable sidewise into the bore.
3. Attach the sensor with the flat side of detached nut from the lower side.
Tighten with a suitable tool (wrench size 40), until a twisting safety of the sensor aligned to the north is given.

II. Mounting into bores

Material thickness for installation of the sensor between the nuts may be max. 10 mm.

1. Remove the thread nut from the sensor.
2. The sensor with cable-plug connection is led without cable into the bore and fastened by the opposite side with the loose nut as under I.3.



When you install the connecting cables make sure not to excessively shorten the cable leading to the connector in the lower part of the sensor casing so that you can later maintain or dismantling the sensor. Put further a cable loop as sensor protection against water under the sensor.



Tip: Install the sensors on ground to the traverse and align you the wind vane parallel to the traverse. You go only then upward, in order to accordingly align the sensors with traverse under assistance of a partner on ground.

6 Setting up the north direction for the wind direction sensor

For wind direction measurements the north mark on the sensor must be aligned with the geographical north direction. You have to turn the marking exactly over the marking at the sensor shaft. When you have aligned the marks, you may fix the wind vane with e.g. a piece of adhesive tape. When you have fixed the wind vane this way you can locate the reference point by aiming at it over the axis. Now you must turn the sensor casing on the mounting tube until the tip of the wind vane points to the reference point in the north.

To set up the sensor's north orientation select a landmark which is as far as possible up north with regard to the final position of the wind direction sensor. The reference point can be selected using a topographical map (1:25000). The exact position of the reference point is determined using an amplitude compass that can be adjusted horizontally on a stand.



Please make sure there is no magnetic deviation of the compass.

When the north direction is set up for the wind direction sensor, you can mounting it as under point "Principle of installation". Remove any adhesive tape.

If you cannot select a northern reference point owing to local conditions, you can proceed analogously using a reference point in the south. In this case, however, you have to make sure the north mark on the sensor does not point to the reference point but in the opposite direction.

7 Electrical connection

PRO-Modbus sensors are connected to a data measuring system via the open cable end. The sensors have a cable-plug connection to the cable. The connecting cable is suitably led along the mast between the data evaluation device (indicating instrument or data acquisition system) and the sensor. The cable must be fastened using appropriate cable ties (their length depends on the mast diameter).



Lead the cable in a wide curve from the mast to the bottom of the casing so that you can later easily dismount the cable.

Please note that the cable on the data processing side is protected against moisture, e.g. by using suitable cable glands. If the mast is prepared accordingly, the connection cable can also be laid completely in the pipe sections of a mast.



To reduce the risk of inductive interference the sensor must be properly grounded (screening on both sides).

8 Heating

The sensor has an electronically controlled 18 W heating within the sensor head. The heating is supplied together with the sensor electronics. (On request a separate supply of the sensor electronics and the heating by a fixed cable is possible.)



Under most climatological conditions the heating prevents blocking of the moving sensor parts (see illustration). The cup rotor or the wind vane are not heated. In case of icing or formation of ice at the moving sensor element the function is restricted for the period of icing.

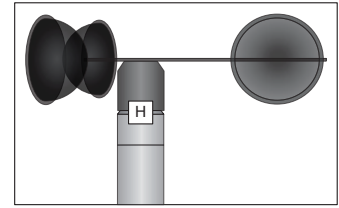

9 Wiring diagram

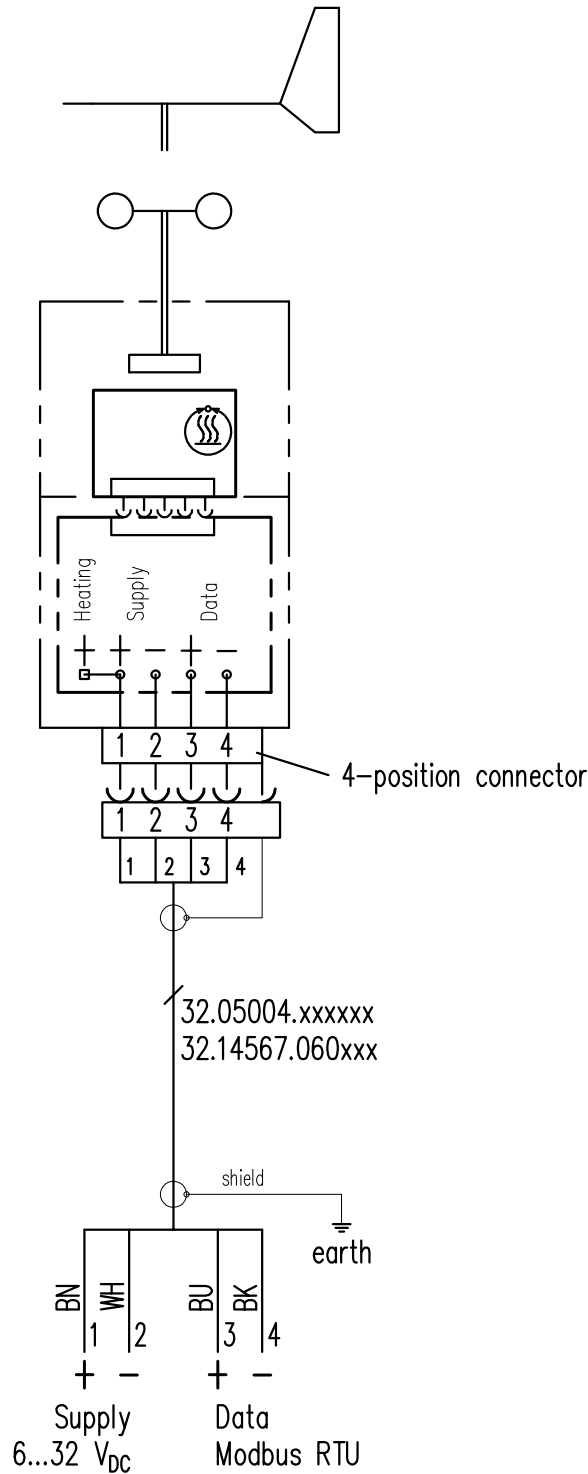

10 Dimensioned drawings

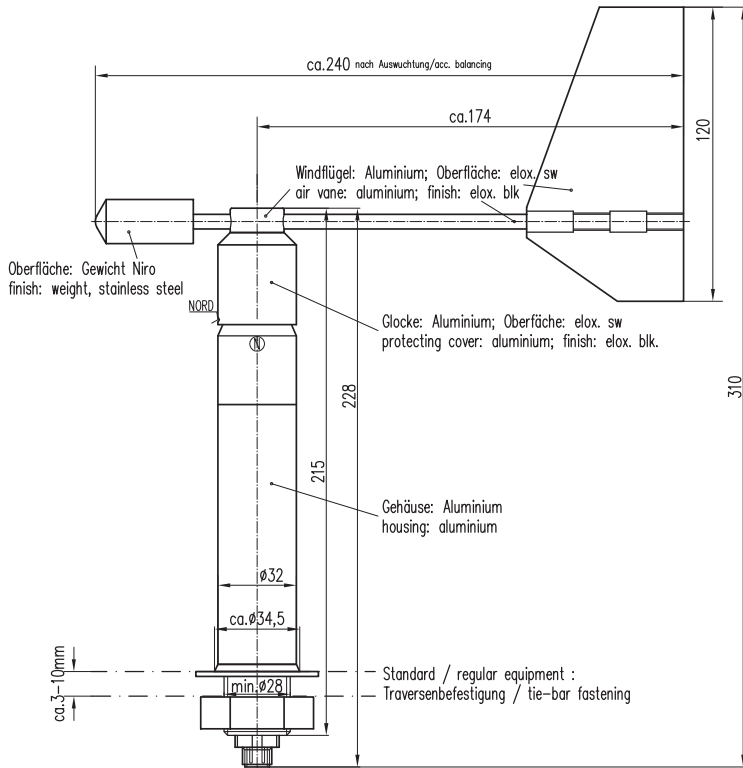

Accessory (optional):

Mast adapter
ID 32.14567.008000

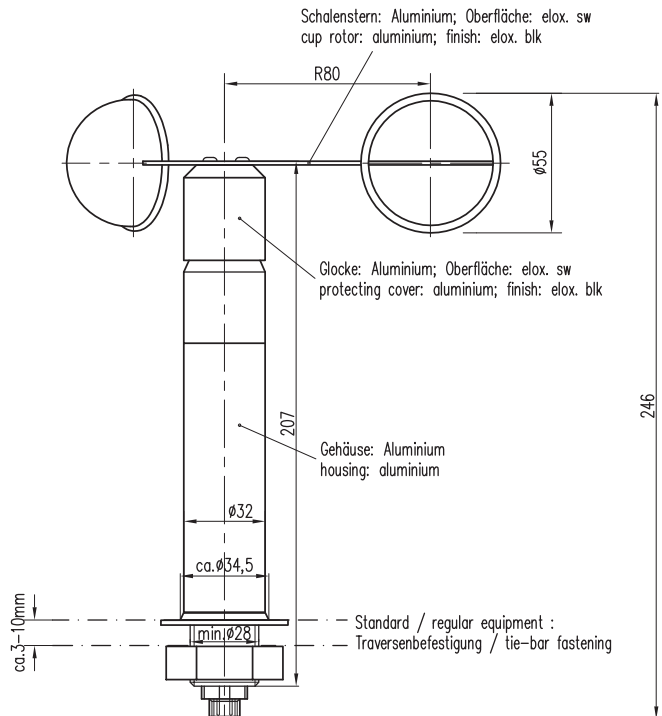
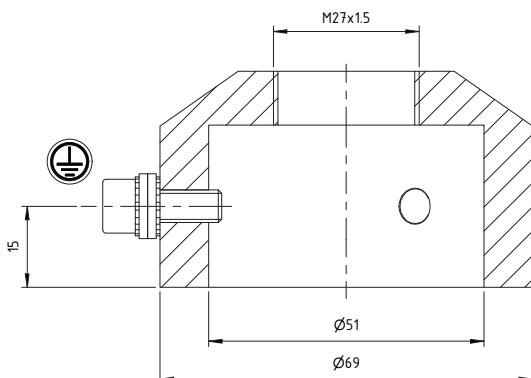

11 Modbus protocol

The LAMBRECHT meteo Modbus sensors and the met[LOG] follow the specification of the Modbus organization: "MODBUS APPLICATION PROTOCOL SPECIFICATION V1.1b3" (see www.modbus.org).

11.1 Data encoding

MODBUS uses the "big-endian" format for addresses and data. This means that if a value is transmitted with a number format that is larger than a single byte, the "most significant byte" is sent first. For values that go beyond one register (e.g. 32 bit) this is not clearly specified for the Modbus. In these cases (32 bit or 64 bit) the LAMBRECHT Modbus sensors follow the big-endian number format.

Example Big-Endian:

Register size value

16 - bits 0x1234 is transmitted in the order: 0x12 0x34.

Example Big-Endian (32 bit or 64 bit):

Register size value

32 - bits 0x12345678 is transmitted in the order: 0x12 0x34 0x56 0x78.

11.2 Device address

The addresses 1...247 are permitted for Modbus.

11.3 Standard configuration - Default

Baud rate: 19200 Baud

Address: Each sensor type (or family) has its own default address.

DEFAULT ADDRESSES OF THE LAMBRECHT SENSORS

Address	Sensor
1	Wind speed
2	Wind direction
3	Precipitation rain[e]
4	THP
5	EOLOS IND
6	com[b]
7	PREOS
8	ARCO
9	u[sonic]
10	Pyranometer 2nd Class
11	Secondary standard Pyranometer
12	PT100 to Modbus converter (temperature)

Byte frame according to MODBUS standard for RTU mode:

8E1 (1 start bit, 8 data bits, 1 parity bit (even parity), 1 stop bit)

11.4 Modbus command set

The LAMBRECHT Modbus sensors support the following commands:

- "Read Input Register" command: 0x04 (measured data)
- "Write Multiple Register" command: 0x10 (write sensor data)

11.5 Measured value and parameter registers

The register range 30001 to 35000 of the LAMBRECHT sensors is intended for measured values.

REGISTER FOR THE WIND SPEED SENSOR 00.14524.101030

Register address	Parameter name	Unit	Factor	Description	
30001	Wind speed instantaneous value	m/s	10	1 decimal place	INT
30002	Wind speed average value since last retrieval	m/s	10	1 decimal place	INT
30003	Wind speed maximum value	m/s	10	1 decimal place	INT
30004	Wind speed minimum value	m/s	10	1 decimal place	INT

Note: The values from the registers with the maximum values and minimum values are automatically reset as soon as the register with the average values has been read out.

REGISTER FOR THE WIND DIRECTION SENSOR 00.14523.131030

Register address	Parameter name	Unit	Factor	Description	
30201	Wind direction instantaneous value	°	10	1 decimal place	INT
30202	Wind direction average value since last retrieval	°	10	1 decimal place	INT
30203	Wind direction maximum value	°	10	1 decimal place	INT
30204	Wind direction minimum value	°	10	1 decimal place	INT

Note: The values from the registers with the maximum values and minimum values are automatically reset as soon as the register with the average values has been read out.

The registers addresses 30001 to 35000 apply to all LAMBRECHT meteo Modbus sensors, but are only available or valid if the respective sensor supports the corresponding values (e.g. a pure temperature sensor does not provide any wind speed)..

The LAMBRECHT sensors give 0xD8F1= 9999(16bit) as error code or invalid value.



11.6 Sensor parameters / Configuration parameters

Register address 40001 to 46000 contains the configuration parameter of the sensor.

Register address	Parameter name	Unit	Divisor	Description	
40001	Modbus device address		1	The addresses 1...247 are allowed.	
40200	Baud rate		0,01	96=9600 192=19200 384=38400	
46000	Number of mapping registers		1	Contains the number of occupied mapping registers for the autoconfiguration	INT

11.7 Mapping register for autoconfiguration

Registers address 46001–49000 containing for each sensor the available registers with measured values and sensor data from the range 30001–35000.



The registers can only be read out as a block! The length of the block or the number of available mapping registers is in holding register 46000.

For example, in the PRO-Modbus wind speed sensor registers 46001 to 46004 contain valid addresses. The holding register 46000 contains the number of registers 4. All 4 registers must be read out in the block with the instruction **0x04**. Too many registers or too few lead to an error message.

11.8 Autoconfiguration

The Modbus sensors from LAMBRECHT meteo offer the possibility of autoconfiguration. This is supported e.g. by the data logger met[LOG]. For the autoconfiguration, the register addresses of the measured values and sensor data available in the register range 30001 to 35000 are listed as consecutive values in the LAMBRECHT sensors in register range 46001 to 49000. Registers 46001 to 49000 can only be read out as a block! The length of the block or the number of available mapping registers is in holding register 46000.

Since the addresses from the range 30001 to 35000 apply to all LAMBRECHT sensors, an address from this range is also representative of a measured value type. For example, register 30401 always contains the current value of the air temperature. If this register address is not included in the list in register range 46001 to 49000, the connected Modbus sensor does not supply an air temperature.

If the autoconfiguration is started with the data logger met[LOG], it queries the available mapping registers on each COM interface in the device address range 1...25. For this purpose, the number of mapping registers is read from register 46000 and the register range from 46001 is read out as a block.

The following table contains the assignment of the configuration to the individual (possible) instantaneous value registers of the sensors. Some sensors deliver registers with mean, minimum and maximum values or additional values beyond this specification. Unknown register addresses (or registers that are not required) must therefore be ignored during autoconfiguration.

Register address	Parameter name	Unit	Factor	Description	Data type	Function code	Storage type >16 bit
30001	Wind speed instantaneous value	m/s	10	1 decimal place	INT	0x04	Big-Endian WORD
30201	Wind direction instantaneous value	°	10	1 decimal place	INT	0x04	Big-Endian WORD
30401	Air temperature instantaneous value	°C	10	1 decimal place	INT	0x04	Big-Endian WORD
30601	Humidity instantaneous value	% r.F.	10	1 decimal place	INT	0x04	Big-Endian WORD
30701	Dew point instantaneous value	°C	10	1 decimal place	INT	0x04	Big-Endian WORD
30801	Air pressure instantaneous value	hPa	10	1 decimal place	INT	0x04	Big-Endian WORD
31001	Precipitation amount total	mm	10	1 decimal place	INT	0x04	Big-Endian WORD
31101	Precipitation amount total (High-WORD)	mm	1000	3 decimal places Registers 31101 and 31102 can only be read out together (function code 0x04)	uLONG	0x04	Big-Endian WORD
31102	Precipitation amount total (Low-WORD)					0x04	Big-Endian WORD
31201	Precipitation intensity 1-minute (sliding)	mm/min	1000	= average (1-min.) 3 decimal places Time base = 1 min. Measuring rate = 6x per min.	INT	0x04	Big-Endian WORD
31401	Global radiation instantaneous value	W/m ²	10	1 decimal place	INT	0x04	Big-Endian WORD
31501	Global radiation instantaneous values (High-WORD) (temperature compensated)	W/m ²	100	2 decimal places Registers 31501 and 31502 can only be read out together (function code 0x04)	LONG	0x04	Big-Endian WORD
31502	Global radiation instantaneous values (Low-WORD) (temperature compensated)					0x04	Big-Endian WORD
31591	Global radiation instantaneous values (High-WORD) (uncompensated)	W/m ²	100	2 decimal places Registers 31591 and 31592 can only be read out together (function code 0x04)	LONG	0x04	Big-Endian WORD
31592	Global radiation instantaneous values (Low-WORD) (uncompensated)					0x04	Big-Endian WORD

11.9 Mapping register

Register address	Register value	Unit	Factor	Description	
46001	30001	Register address	1	Wind speed instantaneous value	INT
46002	30002	Register address	1	Wind speed average value since last retrieval	INT
46003	30003	Register address	1	Wind speed maximum value	INT
46004	30004	Register address	1	Wind speed minimum value	INT
46005	30201	Register address	1	Wind direction instantaneous value	INT
46006	30202	Register address	1	Wind direction average value since last retrieval	INT
46007	30203	Register address	1	Wind direction maximum value	INT
46008	30204	Register address	1	Wind direction minimum value	INT

12 Disposal

LAMBRECHT meteo GmbH is recorded and registered at the Stiftung Elektro-Altgeräte Register ear under:

WEEE reg. no. DE 45445814

In the monitoring and control instrument category, type of device: "Monitoring and control instruments for exclusively commercial use."

Within the EU



The device must be disposed of in accordance with European directives 2002/96/EC and 2003/108/EC (waste electrical and electronic devices). Waste devices must not be disposed of with household garbage! For environmentally friendly recycling and disposal of your waste device, please contact a certified disposal company for electronic waste.

Outside the EU

Please observe the regulations applicable to the proper disposal of waste electronic devices in each country.

13 Technical data - Cable

ID 32.14567.060010

Structure: 4-pole; shielded
 Flame resistance: acc. to UL Style 20549
 Length: 15m

DIMENSIONED DRAWING - CABLE

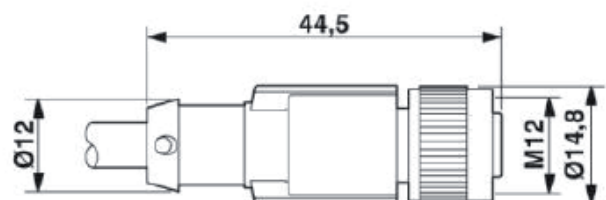

14 Technical data - Sensors

Measuring principle	Hall Sensor Array, non-contact
Range of application	temperatures -40...+70 °C (heated) *; wind speed max. gusts 100 m/s; humidity 0...100 % r. h
Heating	8 W heating; electronically controlled (The heating within the sensor head prevents blocking of the moving parts under most climatological conditions.)
Supply voltage	24 VDC (6...32 VDC)
Current consumption	max. 800 mA at 24 VDC and max. heating • 13 mA at 24 VDC and inactive heating (The heating can be deactivated via software tool. This allows the current consumption to be reduced to 8.5 mA at 24 VDC.)
Housing	seawater-resistant aluminium; IP 65 in upright position; M12 cable-plug connection; stainless steel nut and lock washer
Dimensions	see dimensioned drawings
Scope of delivery	1 sensor (without cable)
For connection to (not included in scope of delivery)	LAMBRECHT meteo data loggers; power supply units; user specific evaluation systems (not included in delivery)
Accessories (please order separately)	ID 32.14565.017000 Traverse (only with 50 mm adapter ID 32.14567.008000) ID 32.14567.010000 Traverse ID 32.14565.019000 Lightning rod

Parameter	Wind direction sensor ID 00.14523.131030	Wind speed sensor ID 00.14524.101030
Measuring element	wind vane; Aluminum; specially coated	3-armed cup rotor; Aluminum; specially coated
Measuring range	0...360°	0.5...75 m/s
Accuracy	± 2°	± 0.3 m/s ≤ 10 m/s; ± 0.5 m/s...60 m/s
Resolution	< 1°	< 0.1 m/s
Starting value	< 0.5 m/s	< 0.5 m/s
Interface	RS485	RS485
Protocol	Modbus RTU	Modbus RTU
Weight	0.4 kg	0.35 kg
Measured values	current value; average value; max. value of the average value; min. value of the average value	



*) Remark: In case of icing and formation of ice at the movable sensor measuring element the function is restricted for the period of icing.
For installation sites with high risk of icing LAMBRECHT provides for specially heated sensors.

Copyright © 2024 LAMBRECHT meteo GmbH. All rights reserved.
Information in this document subject to change without notice.
Photo copyright: © Udo Kroener - Adobe stock

1452x_PRO_Modbus_b-de.indd 20.24

LAMBRECHT meteo GmbH
Friedländer Weg 65
37085 Göttingen
Germany

Tel +49-(0)551-4958-0
Fax +49-(0)551-4958-312
E-Mail info-lambrecht@aem.eco
Internet www.lambrecht.net