



USER MANUAL

u[sonic]

Ultrasonic Wind Sensor



Contents

1	u[sonic] - Benefits at a glance	3
2	Warranty	3
3	Introduction	3
4	Start-up	4
4.1	Installation conditions	4
4.1.1	General	4
4.2	Tools and installation material	5
4.3	Unpacking the sensor	5
4.4	Incoming inspection	5
4.5	Energy supply	6
4.5.1	Current consumption	6
4.6	Installation work (short description)	6
4.7	Mounting the sensor	6
4.7.1	Sensor northing	6
4.7.2	Power supply and signal cables	7
4.7.3	Safety regulations	7
4.7.4	Heating control	8
4.7.5	Download of updates	8
5	Maintenance	9
5.1	Regular maintenance and calibrations	9
5.2	Visual inspections and cleaning	9
6	Transports	9
7	Disposal	9
8	Pin assignment	10
9	Dimensional drawing and side view male connector	11
10	Wiring diagrams	12
10.1	Wiring diagram RS-485	12
10.2	Wiring diagram RS-422	13
10.3	Wiring diagram SDI-12	14
11.	Grounding	15
12	NMEA data protocols	16
13	Modbus protocol	17
13.1	General	17
13.2	Data encoding	17
13.3	Standard configuration - Default	17
13.4	Available Modbus commands	18
13.5	Instantaneous values / real-time values (Input Registers)	18
13.6	Period data - Average, maximum and minimum (Input Registers)	19
13.7	Descriptive sensor parameter registers (Holding Registers)	20
13.8	Configuration registers (Holding Registers)	20
13.9	Autoconfiguration	21
14	SDI-12 Interface	22
15	Technical data	29

1 u[sonic] – Benefits at a glance

The ultrasonic wind sensor u[sonic] was specially designed for extreme environmental conditions. It comes without any moving measuring elements and is ideal for high wind speeds. The extreme robust, compact sensor has a high-quality, pollutant-resistant housing made of hard anodized aluminium and stainless steel.

- Three parameters in one device: Wind direction, wind speed, virtual temperature
- No moving measuring elements
- No mechanical wear, low maintenance requirements
- Standard RS-485 interface with ESD protection
- ASCII data protocol according to NMEA 0183
- Operating voltage (without heating): 6...60 VDC or 12...42 VAC
- Operating voltage (with heating): 24 V AC/DC \pm 20 %
- Easy, space-saving installation on a 50 mm standard pipe
- Analog output: 0...20 mA, 4...20 mA, 0...5 V, or 0...10 V for wind speed and wind direction
- Heating power: 60 W, 120 W, 240 W (standard)

2 Warranty

Please note the loss of warranty and non-liability by unauthorized manipulation of the system. You need a written permission of the LAMBRECHT meteo GmbH for changes of system components. These activities must be operated by a qualified technician.

The warranty does not cover:

1. Mechanical damages caused by external impacts (e. g. icefall, rockfall, vandalism).
2. Impacts or damages caused by over-voltages or electromagnetic fields which are beyond the standards and specifications in the technical data.
3. Damages caused by improper handling, e.g. by wrong tools, incorrect installation, incorrect electrical installation (e.g. false polarity) etc.
4. Damages which are caused by using the device beyond the specified operation conditions.

3 Introduction

The wind sensor u[sonic] is very robust, compact and extremely reliable. When developing this sensor particular consideration has been given to highest quality for fulfilment of meteorological requirements. The system acquires the horizontal air flow and processes the measuring data to the meteorological parameters wind speed and wind direction. The sensor is mounted in a splash water- and dust proof metal housing (IP66 and IP67) and can be immersed temporarily.

The measuring data are automatically transmitted via serial interface RS-485 in talker mode, when power supply is switched on. Due to their shock- and vibration proof construction the sensor u[sonic] is particularly qualified for use under severe environmental conditions. The housing is made of anodized seawater-resistant aluminium and stainless steel. An electronically controlled heating device enables the sensor to operate in between the wide range of -40 up to 70 °C.

ADVANTAGES OF THE STATIC MEASURING PRINCIPLE

The sensor u[sonic] is a modern system to carry out precise and reliable measurements under hardest application and environmental conditions. The wind measurements take place according to the principle “ultrasonic run-time measurement”, i. e. static, without moving parts.

Static measuring principle for wind measurements means:

- Determination of data works without moving measuring elements, i.e. none abrasion and least maintenance.
- The wind parameter can be measured also in winter time accurate and precise, because of the electronic controlled heating for the immovable measuring elements. This heating is particularly effective against ice and snow in all climatic zones.
- The measuring principle enables very low threshold values, distance- and attenuation constants as well as a very high repetition accuracy.

ADVANTAGES OF THE SENSOR

- The built-in test function of the station, enabled by the tight integration of the meteorological sensors into the enclosure, can perform cyclic self-testing and notify the user of erroneous data or failure.
- The compact design of the sensor u[sonic] with three meteorological parameters is eliminating the installation work significantly.

4 Start-up

Wind can be represented by a vector quantity. For a complete description of the wind it is necessary to specify its speed and direction. The two components are subject to spatial and temporal variations; thus, strictly speaking, they are valid only for the site where the measuring instrument is installed. We therefore recommend selecting the place of installation very carefully.

4.1 Installation conditions

4.1.1 General

For professional wind measurements location and height of the wind sensor are important for accurate, correct results and representative wind conditions. Ideally, the sensor should be installed in 10 m above the ground on a mast. This may be buildings, trees, tall towers, lifting cranes, moving vehicles, aircrafts, helicopters and other obstructions.



In case of mobile measurements at vehicles often above mentioned conditions are not practicable. Then you have to find compromises.

Generally, wind measuring instruments should not measure the specific wind conditions of a limited area, but indicate the typical wind conditions of a wider area. The values measured at different places must be comparable. Thus, when installing the sensor you should make sure the place of installation is not under the lee of great obstacles. The distance between the obstacles and the sensor should be 10 times the height of the obstacles (this corresponds to the definition of an undisturbed terrain). If an undisturbed terrain of this kind does not exist the sensor must be put up at a height of at least 6 m above the obstacle height.

If the sensor must be installed on a roof top the place of installation must be in the middle of the roof to avoid predominant wind directions. If you want to measure both wind direction and wind speed, the sensors should be avoided. The sensor u[sonic] easily meets this requirement.



The place of installation should not be in the operation fields of radar devices (radar scanners or radar transmitters), generators or antennas. We recommend a minimum distance of 2 m to these installations. Furthermore a minimum distance of 5 m to MF-/HF- and Satcom- (e. g. Inmatsat, VSat) antennas has to be kept. The maximum electric field intensity may not exceed 10 V/m (tested according to EMC standard). When indicated a greater distance should be kept.

4.2 Tools and installation material

There are no special tools or materials required for the installation works. All work can be carried out with standard tools, e.g. Allen key size 4.

4.3 Unpacking the sensor

The sensor is delivered in separate packaging, carefully protected against mechanical impact, to avoid damage during transport.

The package contains the following items:

- Sensor u[sonic]
- User manual

Accessories: (depending on the scope of delivery, packed separately if necessary)

Connection cable with cable plug

4.4 Incoming inspection

Please check the scope of delivery for completeness and possible transport damage. Please report any complaints immediately to us in writing.



4.5 Energy supply

The sensor requires at the input connector a 6...60 VDC or 12...42 VAC nominal power source for operation. For heating mode a 24 VAC/DC power supply is needed.

4.5.1 Current consumption

The power input of the u[sonic] is around approx. 50 mA at 24 VDC. The following table shows the maximum power input according to configured heating power.

Heating power	Max. current consumption at 24 VDC
60 W	2.5 A
120 W	5 A
240 W (standard)	10 A

By default, the maximum heating power is set to 240 W. The other heating power levels can be factory-set upon request.

4.6 Installation work (short description)

The sensor is installed in three steps:

1. Mounting the cable at the sensor and if necessary draw the cable through the mast.
2. Mounting the sensor at the mast, but before tightening the screws you must align the sensor to the north.
3. Attaching the cable to the power supply and the signal acquisition system.

4.7 Mounting the sensor

The sensor can be installed on a standard pipe with an outer diameter of 50 mm and an inner diameter of maximum 40 mm. Before tightening the two 8 mm-socket screws and attaching the sensor you have to draw the cable through the pipe and align the sensor into driving direction. For this purpose the housing is marked accordingly (see drawing). Before the screws of the sensor are tightened, the sensor is adjusted to north. In addition the sensor has a pin for the north direction. You can put this pin into the nick at the mast (if available). If needed you can turn in or unscrew the pin by means of Allen key.



Please pay attention to a firm mounting of the sensor at the mast!

4.7.1 Sensor northing

For wind direction measurements the north mark on the sensor must be aligned with the geographical north direction. To adjust the wind sensor in a firm and correct manner into the north direction this item is equipped with an



integrated mounting aid. Inside the inner bottom of the sensor a small bolt pointing to the north is integrated to be set into a corresponding slot of the mounting pipe (if available). Thus, the sensor is securely attached. If needed, you can tighten or loosen the pin using an Allen key

To set up the sensor's north orientation select a landmark which is as far as possible up north with regard to the final position of the wind direction sensor. The reference point can be selected using a topographical map (1:25000). The exact position of the reference point is determined using an amplitude compass that can be adjusted horizontally on a stand.



Compass declination has to be considered!

To align the sensor ahead (on ships) locate a point outside the ship in the landscape which is located in the ship ahead direction respectively in the centre line or in case of the sensor is mounted far away from the middle line a line parallel to the centre line. Once the sensor is adjusted, it can be fixed with the two hexagon socket screws. Finally the earth screw has to be connected to the ship's ground. Acid-free contact grease is recommended to protect contact surfaces against corrosion.



Follow all safety instructions while setting up the sensor onto a mast.

4.7.2 Power supply and signal cables

An 8-pin M16 cable connector is required for the electrical connection of the sensor. The cable shield must be clamped to the protective earth (PE) at both ends



The warranty for the device is excluded if damage occurs due to improper handling. This particularly includes the absence of proper grounding. Correct grounding according to DIN VDI/VDE 0100 is essential for the safety and functionality of the device. If you have any questions regarding installation, please contact us.

The external connection is via central connector which is located in housing base. For further details about electrical connection please see chapter "Connecting diagrams". If the sensor is mounted in correct manner and connected with the right cable (accessory), you can attach the wires to power supply and signal outputs to data acquisition equipment (computer).

The typical power supply requirements of the u[sonic] sensors are 24 VDC with a typical current drain of 50 mA. The input range is 6...60 VDC or 12...42 VAC. The heater of the u[sonic] has to be supplied with 24 V AC/DC. In standard configuration the heating power is 240 W with a current drain of 10 A at 24 VDC. The signal output of the sensors is conform to the requirements of RS-422 standard in talker mode. The line drivers are capable of transmitting data over cable lengths up to 1,220 meters (4,000 feet). This maximum distance will vary depending on the quality of the used cables. When the power supply of the sensor is switched on, after 2 seconds the sensor cyclically starts sending data protocols.

4.7.3 Safety regulations



Because the wind sensor often is mounted on exposed locations in dangerous heights the installation personnel has to pay attention to the relevant safety regulations for such works. During the electrical installation and termination works the external circuit-breaker must be switched off. It is not permitted to open those housings by unauthorized persons!

4.7.4 Heating control

The integrated, intelligent heating of the u[sonic] also ensures that the sensor is kept free of ice and snow during winter operation and in locations with critical ambient conditions.

On default, the heating status of the sensor is set to “On” and “Control PIN No Function”.

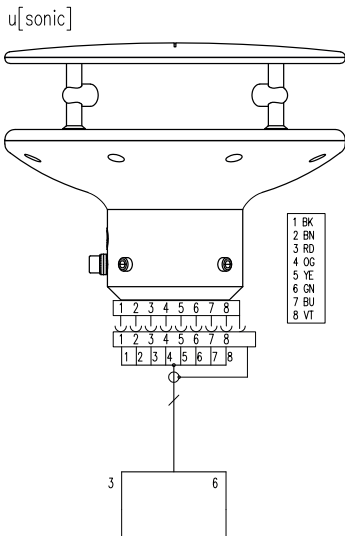

		Heating <A> when 			
		Activ low		Activ high	
<A>					
On	3				
	6				
Off	3				
	6				

Different operating modes are available for controlling and monitoring the heating under moderate temperature conditions. The respective function can be set in the “u[sonic] Commander” configuration software.

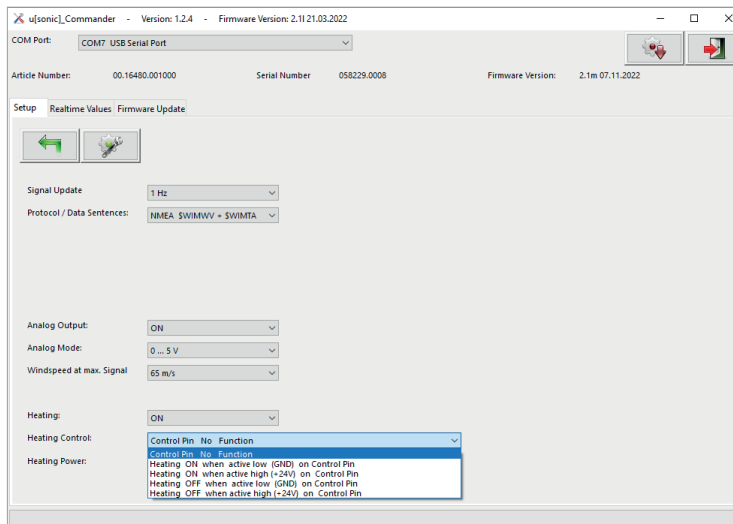

4.7.5 Download of updates

On our website (<https://www.lambrecht.net>), the **Free Software Tools & Firmware** category can be found under **Service** in the **Resources** section. There you can easily download the latest firmware and software tools for your product and benefit from ongoing improvements and new features.

5 Maintenance

5.1 Regular maintenance and calibrations

The sensor u[sonic] is service reduced and designed for a very long lifetime. Recommended is a regular visual check regarding dirt of surface caused by the weather and if so, to clean up.



If reference measurements should be necessary stringently must be noted that a comparability of the measured values is given only if the measurements take place under same conditions. I.e. the reference equipment must be used very close to the sensor!

The sensor is a measuring instrument and thus apply user specific standards regarding period of recalibration. Recommendation: 2 years.

5.2 Visual inspections and cleaning

The use of the sensor under the respective environmental conditions requires certain steps. It is thus recommendable to clean the outside of the housing within specific intervals. The intervals are dependant on the environmental conditions and the degree of soiling. We recommend a regular sight check. In case you should be faced with any specific problems please contact the LAMBRECHT service under:

Tel: +49 (0)551 49580 or E-Mail: support-lambrecht@aem.eco

6 Transports

In case the sensor should be shipped or transported by you, it has to be packed securely to avoid mechanical impact or other damages.

7 Disposal

LAMBRECHT meteo GmbH is listed and registered at the Stiftung Elektro-Altgeräte Register ear under:

WEEE-Reg.-Nr. DE 45445814

In the category of monitoring and control instruments, device type: "Monitoring and control instruments for exclusively commercial use".

Within the EU



The device has to be disposed according to the European Directives 2002/96/EC and 2003/108/EC (Waste Electrical and Electronic Equipment). Do not dispose the old device in the household waste! For an environmentally friendly recycling and disposal of your old device, contact a certified disposal company for electronic waste.

Outside the EU

Please follow the regulations in your country regarding the appropriate disposal of waste electronic equipment.

8 Pinassignment

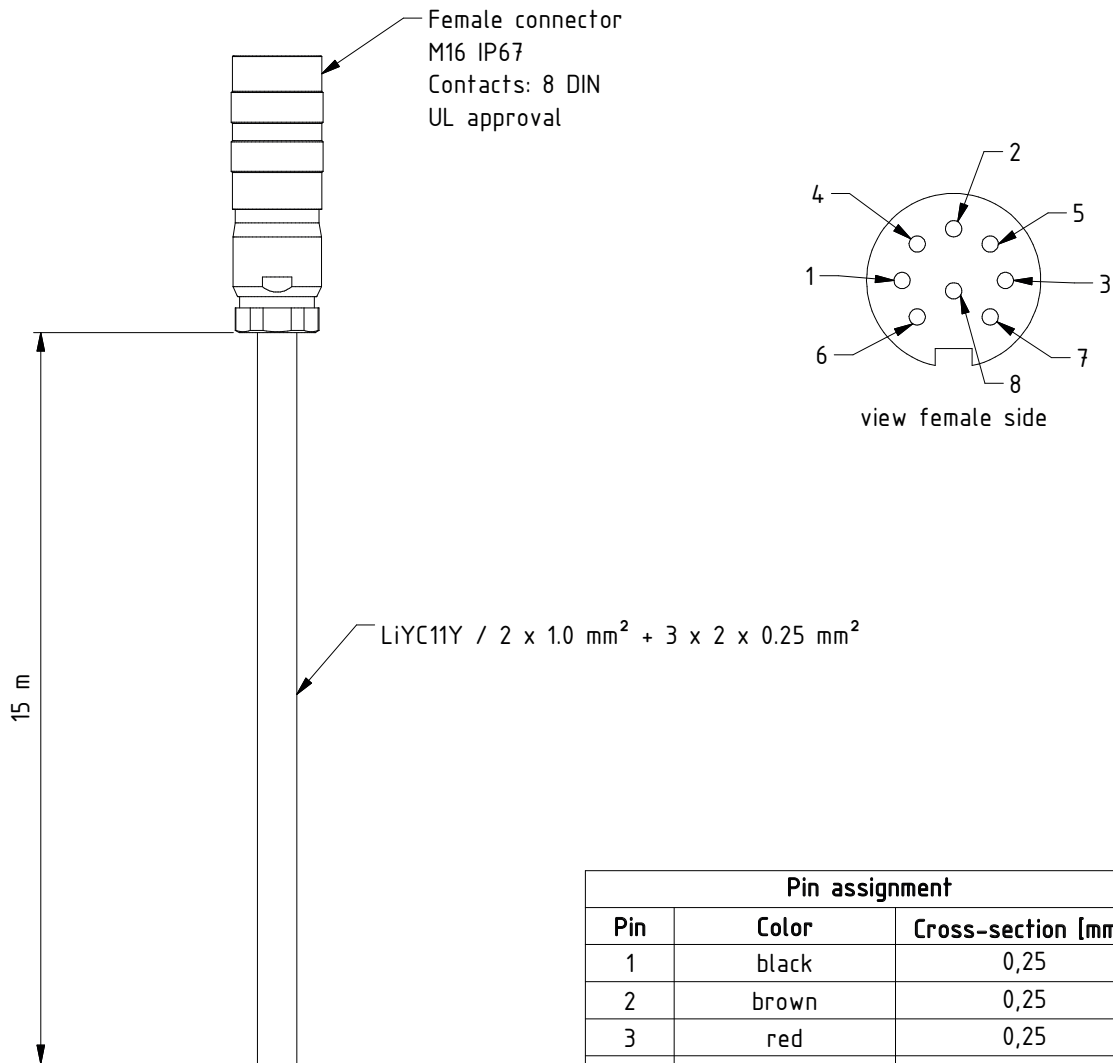

Pin assignment		
Pin	Color	Cross-section [mm ²]
1	black	0,25
2	brown	0,25
3	red	0,25
4	orange	0,25
5	yellow	0,25
6	green	0,25
7	blue	1
8	violet	1



For use in environments with high electromagnetic interference (e.g. caused by motors/generators, frequency converters, or high-voltage power lines), the use of a galvanically isolated DC/DC converter (24 V DC → 24 V DC)* in combination with the u[sonic] is recommended in order to further ensure interference-free operation of the u[sonic].

*) **Note:** As an example reference, a galvanically isolated DC/DC converter from a third-party manufacturer may be used, e.g. **Orion-Tr Smart 24/24-12 by Victron Energy (MPN ORI242428120)**.

The product reference is provided for information purposes only and does not constitute an approval, recommendation, or warranty. The selection, suitability assessment, and responsibility for the use of the third-party product rest solely with the user.

9 Dimensional drawing and side view male connector

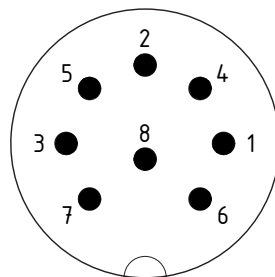
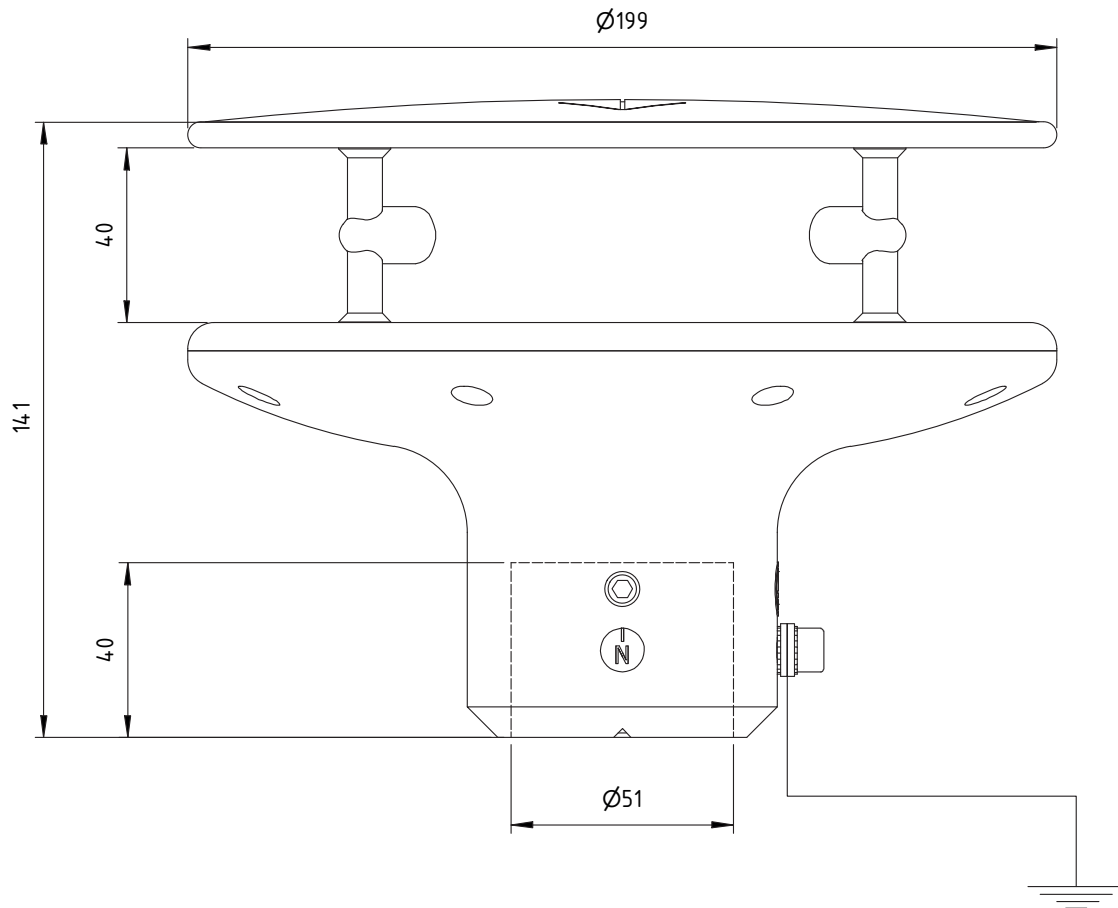

Ansicht Steckerseite
view male side

10 Wiring diagrams

10.1 Wiring diagram RS-485

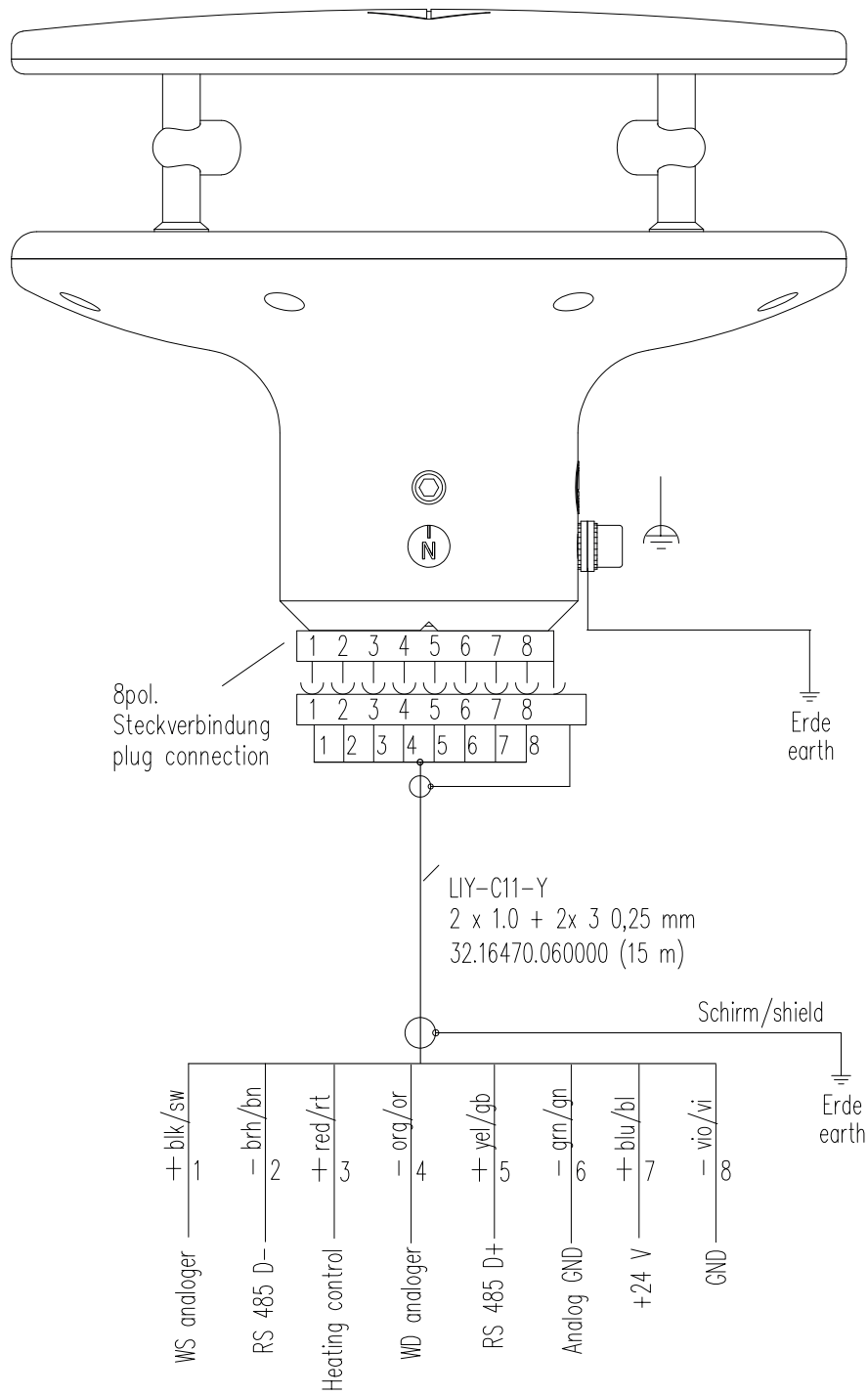

10.2 Wiring diagram RS-422

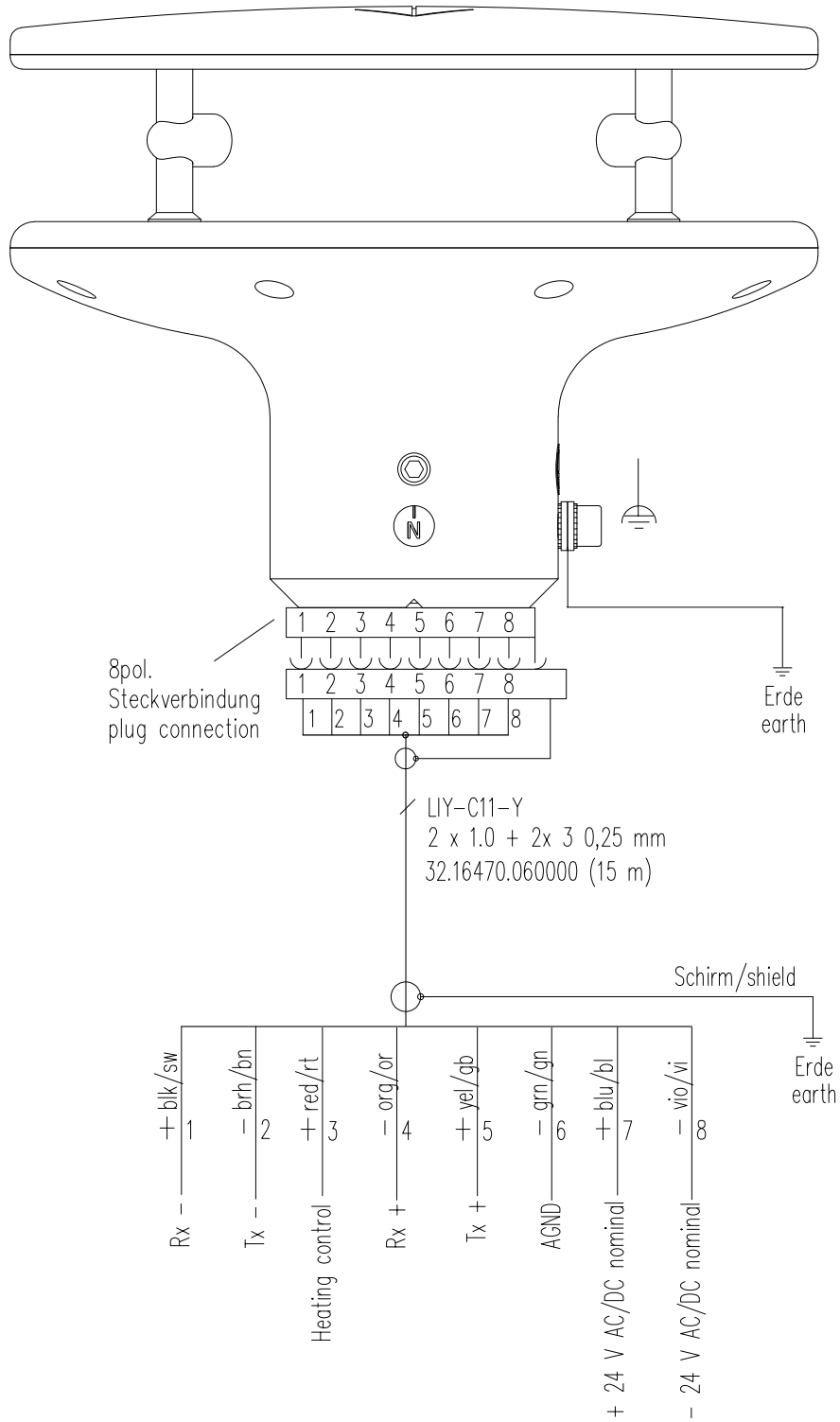

10.3 Wiring diagram SDI-12

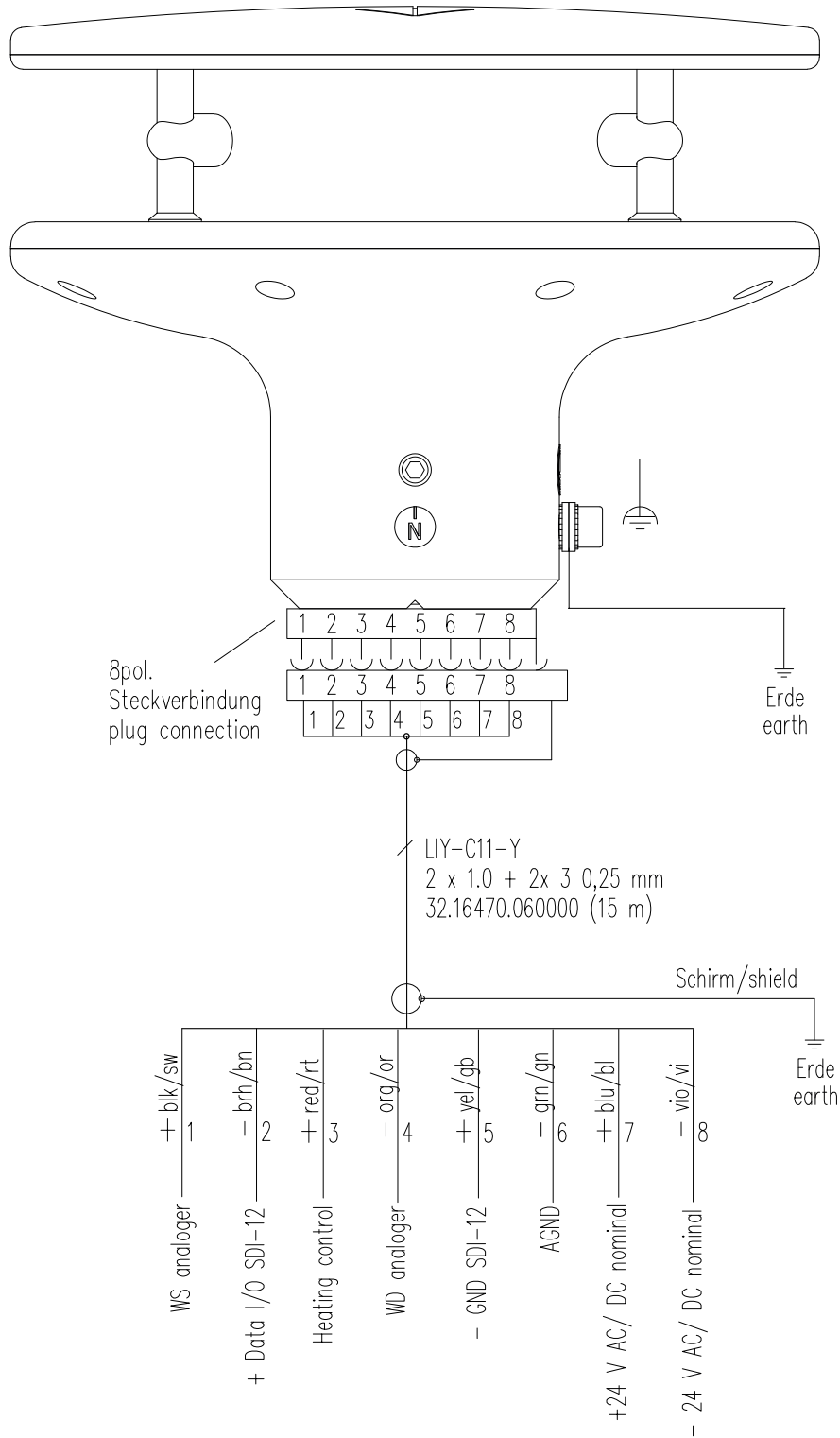

11. Grounding

To ensure the functional operating safety of the sensor, it must be grounded through the integrated grounding screw. This is especially important in areas with:

- Strong electrical fields (e.g., near high-voltage power lines)
- High electrostatic charge
- Increased lightning risk



The warranty for the device is excluded if damage occurs due to improper handling. This particularly includes the absence of proper grounding. Correct grounding according to DIN VDI/VDE 0100 is essential for the safety and functionality of the device. If you have any questions regarding installation, please contact us.

The following figure shows the sequence for installing a grounding wire with a lug through the grounding screw on the sensor.

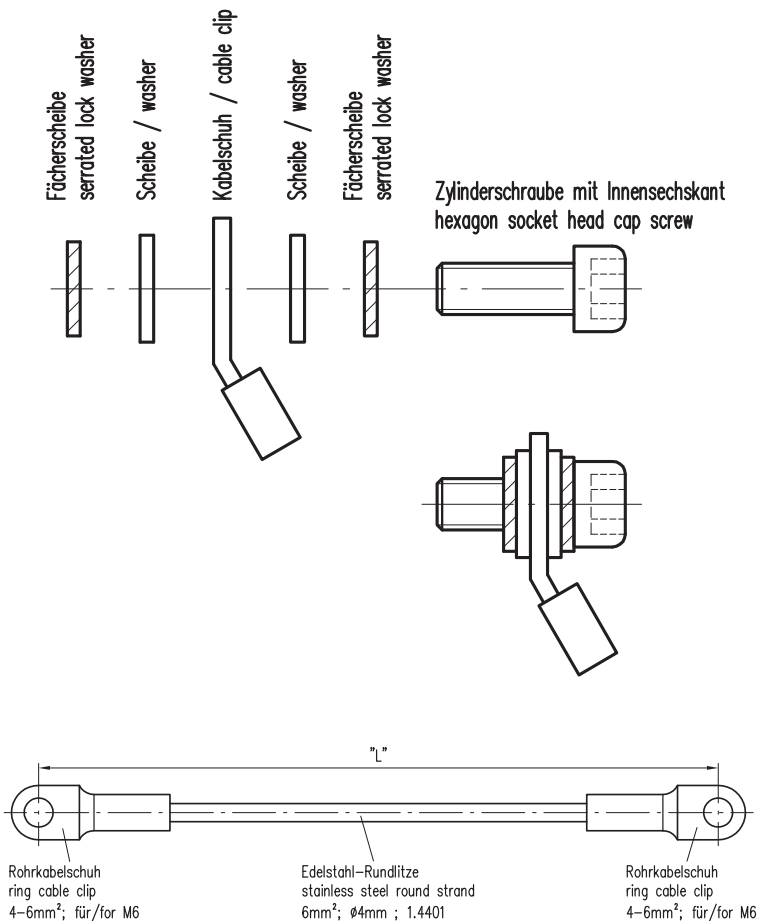

Figure: Example of an grounding cable

12 NMEA data protocols

NMEA COMMUNICATION PARAMETERS

Baud rate: 4800 Baud
 Data Bits: 8
 Parity Bit: None (none)
 Stop Bits: 1 (or more)
 Handshake: without

WIND DIRECTION AND WIND SPEED

Example of data sequence with comma separated fields: \$WIMWV,357.0,R,5.2,M,A*CS<CR><LF>

field delimiter: , (comma)

header: \$WIMWV

wind direction: 0.0...360.0

R: relative wind direction

wind speed: 0.1...85.0

M metric units m/s

status A (valid) / V (not valid)

stop delimiters: <CR> <LF>

error code: WD 999.9

error code: WS 999.9

MESSAGE STRING WIMTA AIR TEMPERATURE

Example of data sequence with comma separated fields: \$WIMTA,-25.0,C*CS<CR><LF>

field delimiter: , (comma)

header: \$WIMTA

temperature: -40.0...+70.0

C: °C

stop limiters: <CR> <LF>

error code: 999.9

REMARK

The development of a NMEA decoder should not be proceeded from firm field lengths. The NMEA definition proceeds from a variable field length. The comma character (',') serves as field disconnecting switch. Numeric values in a field can be represented differently.

In case a field is not sent, it has a length of 0 characters (,,).

The check sum "CS" is covered to two ASCII characters hexadecimal value. "CS" calculated by XOR operation of each characters in the Sentence between "\$" and "*", but excluding "\$" and "*".

<CR> carriage return (hex 0D)

<LF> linefeed (hex 0A)

Further protocols available on request.



13 Modbus protocol

Note: Modbus must be configured in default.

This manual covers the general Modbus specification common to all Modbus sensors from LAMBRECHT meteo. The manual allows easy operation of all LAMBRECHT meteo Modbus sensors. Some sensors of the Modbus family offer additional registers and functions, which are described in separate documents via the registers and functions described here. The registers and functions described in this manual are sufficient for general operation of Modbus sensors in a weather station or PLC.

13.1 General

The LAMBRECHT meteo Modbus sensors follow the specification of the Modbus organization: "MODBUS APPLICATION PROTOCOL SPECIFICATION V1.1b3" (see www.modbus.org).

13.2 Data encoding

MODBUS uses the "Big-Endian" format for addresses and data. This means that if a value is transmitted with a number format which is larger than a single byte, that the "most significant byte" is sent first.

Example Big-Endian:

Register size value 16 - bits

0x1234 is transmitted in the sequence: 0x12 0x34.

To obtain the real measuring value, divide the received register value by the divisor.

Values of -9999 indicate an internal sensor error.

13.3 Standard configuration - Default

Baud rate:	19200 Baud
Byte frame:	8E1 (1 start bit, 8 data bits, 1 parity bit (even parity), 1 stop bit)
RTU Sensor address:	9

DEFAULT ADDRESSES OF THE LAMBRECHT SENSORS

Address	Sensor
1	Wind speed
2	Wind direction
3	Precipitation rain[e]
4	THP
5	EOLOSIND; u[sonic]WS6
6	com[b]
7	PREOS
8	ARCO
9	u[sonic]
10	Pyranometer 2nd Class
11	Secondary standard Pyranometer
12	PT100 ot Modbus converter (temperature)
13	u[sonic]WS7

13.4 Available Modbus commands

The LAMBRECHT Modbus sensors support the following commands:

- “Read Holding Register” command: 0x03 (descriptive sensor data registers)
- “Read Input Register” command: 0x04 (measured values registers)
(every measured value is to be requested individually)
- “Write Multiple Register” command: 0x10 (Write to configuration registers)

13.5 Instantaneous values / real-time values (Input Registers)

The following measured values are provided by the LAMBRECHT meteo sensors.

Register address	Parameter name	Unit	Divisor	Quantity of registers	Access type
30001	Wind speed	m/s	10	1	Read only
30201	Wind direction	°	10	1	Read only

Example: Retrieving the wind speed

0D	04	75	31	00	01	7A	C5	0D	04	02	00	1F	E8	F9
----	----	----	----	----	----	----	----	----	----	----	----	----	----	----

LEN	Transmission Query =>	Source Master	Dest Slave 13	Function Read Input Register (4)	Func Desk Address=30001, Quantity of Register=1	Checksum OK:C57A
LEN	Transmission Response <=	Source Slave 13	Dest Master	Function Read Input Register (4)	Func Desk Byte count=2	Data 00 1F Checksum OK:F9E8

13.6 Period data - Average, maximum and minimum (Input Registers)

Register	Parameter name	Unit	Divisor	Quantity of registers	Access type
30002	Wind speed average	m/s	10	1	Read only
30003	Wind speed maximum	m/s	10	1	Read only
30004	Wind speed minimum	m/s	10	1	Read only
30202	Wind direction average	°	10	1	Read only
30203	Wind direction maximum	°	10	1	Read only
30204	Wind direction minimum	°	10	1	Read only

The data are valid for the period between the current request and the previous request. The maximum range of a period is 1 hour. Recalling the average value of a minimum, maximum and average group will erase the appropriate registers.

Retrieve the values of a group in the sequence minimum, maximum, average.
Use command: 0x03

Example: Retrieve wind speed (min. max. avr.) and erase the register content

01	04	75	34	00	01	6A	08	01	04	02	00	00	B9	30	01
04	75	33	00	01	DB	C9	01	04	02	00	D6	38	AE	01	04
75	32	00	01	8A	09	01	04	02	00	14	B9	3F			

LEN 6	Transmission Query =>	Source Master	Dest Slave 1	Function Read Input Register (4)	Func Desk Address=30004, Quantity of Register=1	Checksum OK:86A
LEN 5	Transmission Response <=	Source Slave 1	Dest Master	Function Read Input Register (4)	Func Desk Byte count=2	Data 00 00 Checksum OK:30B9
LEN 6	Transmission Query =>	Source Master	Dest Slave 1	Function Read Input Register (4)	Func Desk Address=30003, Quantity of Register=1	Checksum OK:C9DB
LEN 5	Transmission Response <=	Source Slave 1	Dest Master	Function Read Input Register (4)	Func Desk Byte count=2	Data 00 D6 Checksum OK:AE38
LEN 6	Transmission Query =>	Source Master	Dest Slave 1	Function Read Input Register (4)	Func Desk Address=30002, Quantity of Register=1	Checksum OK:98A
LEN 5	Transmission Response <=	Source Slave 1	Dest Master	Function Read Input Register (4)	Func Desk Byte count=2	Data 00 14 Checksum OK:3FB9

13.7 Descriptive sensor parameter registers (Holding Registers)

Register	Parameter name	Quantity of registers	Remark	Access type
40050	Device identification number (15 characters)	8 (2 characters in each register)	The returned data are in form of a 16 byte null terminated string	Read only
40100	Serial number (11 characters)	6 (2 characters in each register)	The returned data are in form of a 12 byte null terminated string	Read only
40150	Firmware version (up to 25 characters)	13 (2 characters in each register)	The returned data are in form of a 26 byte null terminated string	Read only

Example: Retrieve the device identification number

(The identification number shown in the example is sensor-dependent. It is only used here for demonstration purposes).

0D	03	9C	72	00	08	CA	8B	0D	03	10	30	30	2E	31	36	□□□□□□□□□□□□□□
34	38	30	2E	30	30	31	31	33	30	00	E8	6B				00.16480.000130□□□□

LEN	Transmission	Source	Dest	Function	Func Desk	Checksum	
6	Query =>	Master	Slave 13	Read Holding Register (3)	Address=40050, Quantity of Register=8	OK:8BCA	
LEN	Transmission	Source	Dest	Function	Func Desk	Data	Checksum
19	Response <=	Slave 13	Master	Read Holding Register (3)	Byte count=16	30 30 2E 31 36 34 38 30 2E 30 30 31 31 33 30 00	OK:6BE8

13.8 Configuration registers (Holding Registers)

Register	Parameter name	Allowed values	Quantity of registers	Access type
40001	Modbus device address		1	Write only
40200	Baud rate	96 = 9600 192 = 19200 384 = 38400	1	Write only
40201	Parity	1 = even 0 = none	1	Write only

The device must be restarted after each change of a setting!

Example: Changing the RTU address from 4 to 1

05	10	9C	41	00	01	02	00	01	06	48	05	10	9C	41	00
01	7E	09													

LEN 9	Transmission Query =>	Source Master	Dest Slave 5	Function Write Multiple Register (16)	Func Desk Address=40001, Quantity=1	Byte count 2	Register values 00 01	Checksum OK:4806
LEN 6	Transmission Response <=	Source Slave 5	Dest Master	Function Write Multiple Register (16)	Func Desk Address=40001, Quantity=1	Checksum OK:097E		

13.9 Autoconfiguration

All LAMBRECHT Modbus sensors offer the experienced user the possibility to implement an auto-configuration in his Modbus master based on additional information stored in the sensor. The necessary information can be found in the document “Lambrecht_Modbus_Autoconfiguration”.

14 SDI-12 Interface



SDI-12 has to be preconfigured ex works.

Please specify when ordering: Id-No. 97.16470.000002 Configuration SDI-12

The communication using SDI-12 protocol via SDI-12 interface is based on the 'SDI-12 A Serial-Digital Interface Standard for Microprocessor-Based Sensors, Version 1.4, 2017'. The u[sonic] can be used in bus mode parallel to other u[sonic].

The following subset of SDI-12 commands were implemented into the u[sonic].

For more information on the SDI-12 protocol, please refer to the standard documentation mentioned above or the website www.SDI-12.org.

IMPLEMENTED SDI-12 COMMANDS

Command	Function	Sensor response
a!	Acknowledge Active	a<CR><LF>
al!	Send Identification	allccccccmmmmmmvvx...xx<CR><LF>
aAb!	Change Address	b<CR><LF>
aM!	Start Measurement	atttn<CR><LF>
aMC!	Start Measurement and Request CRC	atttn<CR><LF>
aC!	Start Concurrent Measurement	atttnn<CR><LF>
aCC!	Start Concurrent Measurement and Request CRC checksum	atttnn<CR><LF>
aDO!	Send Data (Buffer 0)	a<Werte><CR><LF> a<Werte><CRC><CR><LF>
aV!	Start Verification	atttn<CR><LF>
aX!	Resetting the Addresses	a<CR><LF>

a = Address of the corresponding sensor

Standard sensor addresses = 0

SDI-12 commands always start with the address of the appropriate sensor. Therefore all other sensors on the same bus will ignore these commands. SDI-12 commands end with '!'. All answers from sensors start with its address, too, but end with the ASCII characters 'Carriage Return' <CR> and 'Line Feed' <LF>.

The SDI-12 protocol is based on the ASCII character set. The baud rate of the SDI-12 protocol is 1200 Bd and has the byte frame format:

- 1 start bit
- 7 data bits (least significant bit transmitted first)
- 1 parity bit (even parity)
- 1 stop bit

Acknowledge Active - a!

This command ensures that the sensor responds to requests. Basically it asks the sensor to confirm that it is connected to the bus.

The sensor returns its address and <CR><LF>.



Syntax

Command	Answer
a! a – Sensor address ! – End of command	a<CR><LF> a – Sensor address <CR><LF> – End of answer

Example:

Command	Answer
0!	0<CR><LF>
1!	1<CR><LF>

Send Identification – a!

The command **a!** is used to ask the sensor for its model number and firmware version.

Syntax

Command	Answer
a! a – Sensor address ! – Command “Send Identification” ! – End of command	a14LMGmbH151647011.1<CR><LF> a – Sensor address a14LMGmbH151647011.1 14 – 2 characters SDI-12 version no. 14 = version 1.4 LMGmbH15 – 8 characters manufacturer’s name (= Lambrecht meteo GmbH) 164701 – 6 characters sensor type 1.1 – Firmware version <CR><LF> – End of answer

Example:

Command	Answer
0!	014LMGmbH1514582S1.1<CR><LF>
1!	114LMGmbH1514582D1.1<CR><LF>

Change address – aAb!

The factory setting for the address is “0”. If there are several sensors connected to one bus, the sensor address can be changed with the command “aAb!”. The address is always a single ASCII character. Standard for addresses are the ASCII characters “0” to “9” (decimal 48 to 57). If there are more than 10 sensors connected to one bus, using the characters “A” to “Z” (decimal 65 to 90) and “a” to “z” (decimal 97 to 122) is allowed. The sensor answers with its new address and <CR><LF>. After the address is changed, one should not send further commands to the sensor for a period of one second (see also “SDI-12 Standard, Version 1.4, 2017”).

Syntax

Command	Answer
aAb! a – Old sensor address A – Command “Change Address” b – New sensor address ! – End of command	b<CR><LF> b – New sensor address <CR><LF> – End of answer

Example:

Command	Answer
0A1!	1<CR><LF>

Start Measurement – aM!

The command **aM!** requests that the sensor processes the returning string and provide the available measured data. In contrast to standard sensors described in the SDI-12 documentation the [u]sonic measures continuously. Thus the measured values from the continuous measurement are stored in a buffer while the string is being processed. These values are processed after the string processing. Therefore the [u]sonic always responds with “**a000**”. This is also the reason why the [u]sonic does not send a “**Service Request**” and ignores signals to interrupt the measurement. Prior to the returned waiting time the data logger must not send further commands. After expiration of the waiting time the data can be requested with the commands **aD0!** and **aD1!** (see “**Send Data**”). The data will not be overwritten until the next **C**, **M**, or **V** command and can be read several times until then.

Syntax

Command	Answer
aM! a – Sensor address M – Command “Start Measurement” ! – End of command	a0003<CR><LF> a – Sensor address 000 – Seconds the sensor needs until the measured data can be returned 3 – Number of provided measured data <CR><LF> – End of answer

Example:

Command	Answer
1M!	10003<CR><LF>

The measured data can be requested with the commands **aD0!** and **aD1!** (see “**Send Data**”).

Start Measurement and Request CRC – aMC!

Same command as **aM!** but in addition to the generated data the sensor returns a 3-digit CRC checksum. For information on how the CRC checksum is generated, please consult “SDI-12 Standard, Version 1.3, 2012, chapter 4.4.12”.



Syntax

Command	Answer
aMC! a – Sensor address M – Command “Start Measurement and Request CRC” C – Request for transmission of the CRC checksum ! – End of command	a0003<CR><LF> a – Sensor address 000 – Seconds the sensor needs until the measured data can be returned 3 – Number of provided measured data <CR><LF> – End of answer

Example:

Command	Answer
2MC!	20003<CR><LF>

Start Concurrent Measurement – aC!

The “Concurrent Measurement” enables the data logger to measure simultaneously with multiple sensors on the same bus. The “**aC!**” command requests the sensor to process the available measurement data and write them to an output string. Unlike the standard sensors described in the SDI-12 documentation, the u[sonic] measures continuously. This is why the u[sonic] always responds with “**a000**”. The data is therefore immediately available. This is also the reason why the u[sonic] does not send a “service request” and ignores measurement interruption commands. The data can be retrieved with the command “**aDO!**” (see under “**Send Data**”). The data is not overwritten until the next “**C**” or “**M**” command and can be retrieved several times.

Syntax

Command	Answer
aC! a – Sensor address C – Command “Start Concurrent Measurement” ! – End of command	a00014<CR><LF> a – Sensor address 000 – Seconds the sensor needs until the measured data can be returned (= 0 s – Data immediately available) 14 – Number of provided measured data <CR><LF> – End of answer

Example:

Command	Answer
1C!	100014<CR><LF>

The measured data can be requested with the command “**aDO!**” (see “**Send Data**”).

Start Concurrent Measurement with CRC – aCC!

Same command as “**aC!**” but in addition to the generated data the sensor returns a 3-digit checksum. For information on how the CRC checksum gets generated, please consult ‘SDI-12 Standard Version 1.4, 2017, chapter 4.4.12’.

Syntax

Command	Answer
aCC! a – Sensor address C – Command “Start Concurrent Measurement” C – Request to send a CRC checksum ! – End of command	a00014<CR><LF> a – Sensor address 000 – Seconds the sensor needs until the measured data can be returned with “CRC” (= 0s – Data immediately available) 14 – Number of provided measured data <CR><LF> – End of answer

Example:

Command	Answer
1CC!	100014<CR><LF>

Send Data – aDO!

The data requested by the sensor with the commands “**C**” or “**M**” can be retrieved with the command “**aDO!**”. The sensor uses the corresponding signs (“+” or “-”) as field separators. If the data was requested with a “**CC**” or “**MC**” command, a CRC checksum is also returned. For more information on how to generate this CRC checksum, please see “SDI-12 Standard, Version 1.4, 2017, chapter 4.4.12”.

After the measurement, the data is stored in the buffer “**DO**” and retrieved with the command “**aDO!**”.

Command	Answer
aDO! a – Sensor address D – Command “Send Data” 0 – Request for the data in buffer 0 or 1 = buffer 1 2 = buffer 2 ! – End of command	a<values><CR><LF> a – Sensor address <values> – Requested data separated by respective sign (“+” or “-”) <CR><LF> – End of answer

Example:

Command	Answer
0C!	000004<CR><LF>
0D0!	0+0.1+0.1+0.1+0.1<CR><LF>

Syntax for measurements with aCC! or aMC!

Command	Answer
aDO! a – Sensor address D – Command “Send Data” 0 – Request for the data in buffer 0 or 1 = buffer 1 ! – End of command	a<values><CRC><CR><LF> a – Sensor address <values> – Requested data separated by respective sign (“+” or “-”) <CRC> – 3-digit CRC checksum <CR><LF> – End of answer



Definition SDI-12 u[sonic] C! and CC!

	Nr.	Parameter	Description	Unit
DO!	1	Wind speed	Instantaneous value	m/s
	2	Wind speed	Minimum value	m/s
	3	Wind speed	Maximum value	m/s
	4	Wind speed	Average value	m/s
	5	Wind direction	Instantaneous value	deg
	6	Wind direction	Minimum value	deg
	7	Wind direction	Maximum value	deg
	8	Wind direction	Average value	deg
D1!	9	Acoustic virtual temperature	Instantaneous value	°C
	10	Acoustic virtual temperature	Minimum value	°C
	11	Acoustic virtual temperature	Maximum value	°C
	12	Acoustic virtual temperature	Average value	°C
D2!	13	Status code	16 bit value	
	14	Error code	16 bit value	

Minimal, maximum and average value refer to the time since last C! or CC! command.

Syntax for measurements with command “aC!” or “aM!”

Error/status code

The returned value is a decimal format of an originally binary number.
 In binary notation, the digits correspond to the following error messages.

Error:

XXXXXXXX	XXXXXXXX	Bit:	Dec:	Hex:	Meaning:
	_	0	1	00 01	Supply voltage error (with inactive heating)
	_	1	2	00 02	Supply quality (power good)
	_	2	4	00 04	Supply voltage error (with active heating)
	_	3	8	00 08	Measuring section disturbed
	_	4	16	00 10	RTC initialization error
	_	5	32	00 20	Electronic overload protection
	_	6	64	00 40	Electronics error
	_	7	128	00 80	Error in backup SRAM
	_	8	256	01 00	NTCs defective
	_	9	512	02 00	Heating control temperature not available

Status:

XXXXXXXX	XXXXXXXX	Bit:	Dec:	Hex:	Meaning:
	_	0	1	00 01	Restart (reset) (is output 5 times)
	_	1	2	00 02	Watchdog triggered (is output 5 times)
	_	2	4	00 04	Heating active (heats)
	_	3	8	00 08	Reflection detection
	_	4	16	00 10	Gain adjusted in case of signal interference
	_	5	32	00 20	Measurement quality (less than 50% on average)

Description for aM! and aMC!

	No.	Description
DO	1	windspeed.mom
	2	winddirection.mom
	3	virtual_temperature.mom

15 Technical data

Combined Ultrasonic Wind Sensor u[sonic]	
ID	00.16470.100000 Modbus and SDI-12 are pre-configured ex-works. <u>Please specify when ordering:</u> ID 97.16470.000001 Configuration Modbus ID 97.16470.000002 Configuration SDI-12
Measuring principle	Ultrasound
Measuring range	Wind direction: 0...359.9°; wind speed: 0...75 m/s
Survival wind speed	100 m/s
Accuracy	Wind direction: < 2° (> 1 m/s) RMSE Wind speed: 0.2 m/s RMSE (v < 10 m/s); 2 % RMSE (10 m/s < v < 65 m/s)
Resolution	Wind direction: 0.1° Wind speed: 0.1 m/s
Response threshold	0.1 m/s (adjustable for wind direction)
Outputs	RS 485; analog: 4...20 mA; (0...65 m/s); (other scalings on request) (Outputs on request: RS-422; SDI-12; analog: 0...20 mA; 0...5 V; 0...10 V)
Protocols	NMEA 0183, WIMWV, WIMTA (Protocols on request: SDI-12, Modbus RTU)
Measuring rate	0.1...10 Hz; (internal measuring rate 50 Hz)
Operating conditions	-40...+70 °C (with heating -50...+70 °C); 0...100 % r. h.
Supply voltage	Without heating: 6...60 VDC oder 12...42 VAC; with heating: 24 VAC/DC ± 20 %
Current consumption	Sensor: typically 50 mA at 24 VDC and deactivated analog output; Heating: maximal 10 A at 24 VAC/DC
Heating data	Factory configurable: 60 W / 120 W / 240 W (standard)
Dimensions	Ø 199 mm; height 149 mm
Housing	Seawater resistant aluminum; IP66, IP67
Weight	Approx. 2 kg
Standards	<ul style="list-style-type: none"> • NMEA 0183 • VDE 0100 • Low voltage guide line: 72/23 EWG • EMC/EMI: DIN EN 60945 and DIN EN 61000-4-2, -3, -4, -5, -6, -11 • Protection class: DIN EN 60529
Accessories (please order separately)	
ID 32.16470.060000	Sensor cable, 15 m, 8-pin, M16 connector