

# GESAMTPROGRAMM Complete Range 2015 | 2016

PROFESSIONAL  
**HOTEL**  
EQUIPMENT



# Inhalt

## contents



### Besteck flatware



Besteckmodelle  
flatware collections

Besteck Ergänzungsteile  
neutral serving pieces

Asia

Kinderbestecke  
childrens flatware



### Table Top table top



Getränke heiß & kalt  
beverages hot & cold

- Culture Cup
- KaffeeKultur /  
coffeeCulture
- Tee & Kaffee /  
tea & coffee
- Wein/  
wine
- Kaltgetränke /  
cold drinks

Servieren  
serving

- Platzteller & Clochen /  
plate trays & covers
- Serviergeräte /  
serving utensils
- Tisch Accessoires /  
table accessories
- Körbe & Schalen /  
baskets & bowls

Tischdekoration  
table decoration

- Kerzen & Leuchter /  
candles & lamps
- Vasen /  
vases
- Tischnummern /  
table numbers

Würzen  
spice it up

- Mühlen & Menagen /  
grinding &  
condiment sets



### Buffet buffet



combiNation Buffet  
combiNation buffet

Warmhalten  
keeping warm

- Chafing Dishes Induktion /  
chafing dishes induction
- Chafing Dishes /  
chafing dishes
- Chafing Dish Zubehör /  
chafing dish accessory
- Coffee Urns /  
coffee urns

Dosieren  
portioning

- Dispenser /  
dispenser

Präsentieren  
presenting

- Getränke Kühler /  
Beverage cooler
- Étagères /  
étagères
- Plattenständer /  
Tray stands
- Platten & Tablett /  
platters & trays
- Körbe & Schalen /  
baskets & bowls



**Trends & Themen** **IV**  
trends & topics

Pure Exclusiv Colour	PVD-Besteck PVD-cutlery	Hotelzimmer rooms	Apartments apartments
Glas glass	Servierwagen serving trolleys	Küche kitchen	Kaffeemaschinen coffeemachines

**Besteck**  
flatware



**Pflege & Reparatur** **V**  
maintenance & repair

Material material	Aufarbeitung & Reparatur refurbishment & repair	Pflege-Tipps maintenance
Pflegemittel cleaning aids		

**Table Top**  
table top

**Buffet**  
buffet

**A-Z** **Gesamt-Inhaltsverzeichnis** **VI**  
alphabetical index

**Trends & Themen**  
trends & topics

**Pflege & Reparatur**  
maintenance & repair





## Kompetenz & Design Expertise & Design

Bereits seit 1853 beschäftigt sich die Württembergische Metallwarenfabrik AG mit Produkten rund um die gepflegte Gastlichkeit. Diese langjährige Erfahrung ist sicherlich ein Faktor für unsere Fachkompetenz und Basis für den renommierten Namen, den die WMF weltweit in der Gastronomie und Hotellerie genießt.

Auch in Zukunft werden wir alles daran setzen, diesen guten Ruf zu bestätigen und weiter auszubauen. Kundenfreundliche Komplettlösungen aus einer Hand bieten zu können ist eine unserer größten Stärken. So ist es uns möglich, auch den individuellen Anforderungen Ihres Betriebes gerecht zu werden.

Dieser Katalog zeigt Ihnen die Bandbreite unserer WMF Hotel Produktpalette. Produkte, gestaltet von international anerkannten Designern, hergestellt mit modernsten umweltfreundlichen Fertigungstechniken in denkbar bester Qualität.

Since as long ago as 1853 Württembergische Metallwarenfabrik AG has been involved in the manufacture of products covering all aspects of hospitality. This long experience is without doubt a factor in our specialised expertise and is the basis for the excellent reputation that WMF enjoys in the hotel and catering industry throughout the world.

Our objective for the future is to maintain and enhance our good name. WMF Hotel can provide customer-orientated all-in-one solutions from a single source to satisfy the particular requirements of your business.

This combined catalogue shows you the range of our varied WMF Hotel product line. Products created by internationally renowned designers and produced by the very latest in environmentally-friendly manufacturing methods of the highest possible quality.



chrom poliert



Karl Wagenfeld

chrom-matt



Jette Joop



## Innovation Innovation

Wir investieren in Ideen.  
Eine Innovation ist die Verwirklichung einer guten Idee. Wir stellen im Interesse unserer Kunden die Ressourcen in Forschung, Entwicklung, Design und Management bereit, die aus Gedanken Entwürfe und aus Entwürfen neue Produkte entstehen lassen.

We invest in ideas.  
An innovation is the realization of a good idea. In the interest of our customers, we provide the resources in research, development, design and management that it takes to turn ideas into designs and designs into new products.

## Entwicklung Development

Ein Maßstab bei der Entwicklung unserer Produkte ist Ihr harter gastronomischer Alltag. Dieser stellt an Verarbeitung und Anwenderfreundlichkeit die höchsten Anforderungen.

One criterion in the development of our products is the stress of daily catering use. That means workmanship and user-friendliness have to meet the highest standards.



## Stilbewusstsein Sense of style

Das Zubereiten, Anrichten und Servieren von Speisen und Getränken ist eine Kunst. Wir unterstützen Sie dabei mit einer Bandbreite von Produkten, die ihresgleichen sucht.

The preparation, presentation and serving of food and drink is an art. We can assist you with an unrivalled range of products.

## Produktvielfalt Product diversity

Ob stilvoll, modern, jung oder sachlich ... bei WMF Hotel finden Sie genau die Produkte, die Ihrem persönlichen Einrichtungsstil gerecht werden.

Stylish, modern, young or down-to-earth ... in WMF Hotel you will find just the right products to suit your individual equipment style.





# Qualität quality



Silberauflage in  
Hotelqualität  
hotel grade silver plating



Individualisierung,  
z. B. durch Gravur oder  
Stempelung  
customisation, e.g. by  
engraving or stamping



Gabelzinken innen  
bearbeitet  
inside-machined  
fork prongs



Ausgewogene Balance  
jedes Besteckteils  
each piece of cutlery  
perfectly balanced

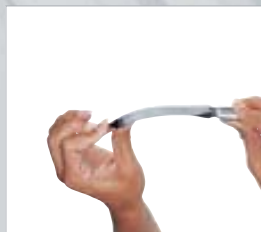

Klingen der Hohlheftmesser  
aus geschmiedetem  
Spezial-Klingenstahl  
blades of hollow handle  
knives made from  
special blade steel



Zertifiziert nach  
DIN EN ISO 9001 - 2008

Certified in  
accordance with  
DIN EN ISO 9001 - 2008



Cromargan®: Edelstahl  
Rostfrei 18/10 -  
korrosionsbeständig,  
unempfindlich

Cromargan®: stainless  
steel 18/10 - corrosion-  
resistant, non-sensitive



Spülmaschinenfest  
dishwasher safe



Gastronomiegerechte  
Materialstärke

correct material thickness  
for the catering industry



Tropffreie Kannen  
non drip jugs



Kondenswasserrücklauf  
condensation return



Hitzeisolierte Griffe  
insulated handles



Hitzebeständige Griffe  
heat resistant handles



Reparatur-Service &  
Aufarbeiten

repair service &  
refurbishment





# BESTECK flatware



**Besteckmodelle**  
flatware collections

**Besteck Ergänzungsteile**  
neutral serving pieces

**Kinderbestecke**  
childrens flatware



# BESTECK FLATWARE

## MODELLE COLLECTIONS



CASINO 9000



BAGUETTE 0100



JUWEL 7300 ■ ■



EPOS 1600



SIGNUM 1900



NORDIC 7200



SOLID 7900



UNIC 5300



**BISTRO 0400**



**CLUB 4700**



**BASE 2300**



**BESTECK FÜR  
MAGNETISCHE  
ABNAHME**  
Cutlery for magnetic removal

**AUF  
UNSERER  
HOMEPAGE**  
on our Homepage



**CONTOUR 0200**



**RESIDENCE 4800**



**METROPOLITAN 5400**



**TELOS 1800**



**BAROCK 3200**



**FLAIR 1100**



**MONDIAL 6200**



**GASTRO 0800**



■ 54.7301.6030  
■ 54.7301.6040

**Menuelöffel**

213 mm/8<sup>1</sup>/<sub>4</sub> in.  
table spoon  
cuiller de table  
cuchara mesa  
cucchiaio tavola



■ 54.7302.6030  
■ 54.7302.6040

**Menuegabel**

211 mm/8<sup>1</sup>/<sub>4</sub> in.  
table fork  
fourchette de table  
tenedor mesa  
forchetta tavola



■ 54.7303.6037  
■ 54.7303.6047

**Menuemesser\***

236 mm/9<sup>1</sup>/<sub>4</sub> in.  
table knife\*  
couteau de table\*  
cuchillo mesa\*  
coltello tavola cutinato\*



■ 54.7303.6039  
■ 54.7303.6049

**Menuemesser\*\***

239 mm/9<sup>1</sup>/<sub>2</sub> in.  
table knife\*\*  
couteau de table\*\*  
cuchillo mesa\*\*  
coltello tavola cutinato\*\*



■ 54.7310.6030  
■ 54.7310.6040

**Vorspeisen- /  
Dessertlöffel**

159 mm/6<sup>1</sup>/<sub>4</sub> in.  
coffee/tea spoon, large  
cuiller à café/thé, grande  
cuchara à café/té, grande  
cucchiaio caffè/té, grande



■ 54.7311.6030  
■ 54.7311.6040

**Gourmetlöffel**

193 mm/7<sup>1</sup>/<sub>2</sub> in.  
gourmet spoon  
cuiller à sauce  
cuchara gourmet  
cucchiaio gourmet



■ 54.7335.6030  
■ 54.7335.6040

**Fischgabel**

190 mm/7<sup>1</sup>/<sub>2</sub> in.  
fish fork  
fourchette à poisson  
tenedor pescado  
forchetta pesce



■ 54.7336.6030  
■ 54.7336.6040

**Fischmesser**

214 mm/8<sup>1</sup>/<sub>2</sub> in.  
fish knife  
couteau à poisson  
cuchillo pescado  
coltello pesce



■ 54.7304.6030  
■ 54.7304.6040

**Vorspeisenlöffel**

196 mm/7<sup>3</sup>/<sub>4</sub> in.  
dessert spoon  
cuiller à dessert  
cuchara postre  
cucchiaio frutta



■ 54.7340.6030  
■ 54.7340.6040

**Austerngabel**

149 mm/5<sup>3</sup>/<sub>4</sub> in.  
oyster fork  
fourchette à huîtres  
tenedor ostras  
forchetta per ostriche



■ 54.7305.6030  
■ 54.7305.6040

**Vorspeisengabel**

194 mm/7<sup>3</sup>/<sub>4</sub> in.  
dessert fork  
fourchette à dessert  
tenedor postre  
forchetta frutta



■ 54.7364.6030  
■ 54.7364.6040

**Kuchengabel**

158 mm/6<sup>1</sup>/<sub>4</sub> in.  
cake fork  
fourchette à gâteau  
tenedor lunch  
forchetta per dolce



■ 54.7306.6037  
■ 54.7306.6047

**Vorspeisen-  
messer\***

212 mm/8<sup>1</sup>/<sub>4</sub> in.  
dessert knife\*  
couteau à dessert\*  
cuchillo postre\*  
coltello frutta\*



■ 54.7366.6039  
■ 54.7366.6049

**Brot- /  
Buttermesser\*\***

170 mm/6<sup>3</sup>/<sub>4</sub> in.  
bread/butter knife\*\*  
couteau de table\*\*  
cuchillo lunch  
coltello per dolce\*\*



■ 54.7306.6039  
■ 54.7306.6049

**Vorspeisen-  
messer\*\***

220 mm/8<sup>3</sup>/<sub>4</sub> in.  
dessert knife\*\*  
couteau à dessert\*\*  
cuchillo postre\*\*  
coltello frutta\*\*



■ 54.7372.6030  
■ 54.7372.6040

**Limolöffel**

220 mm/8<sup>3</sup>/<sub>4</sub> in.  
iced tea spoon  
cuiller à soda  
cuchara refresco  
cucchiaio bibita



■ 54.7307.6030  
■ 54.7307.6040

**Kaffeelöffel**

136 mm/5<sup>1</sup>/<sub>4</sub> in.  
tea/coffee spoon  
cuiller à café  
cuchara café  
cucchiaio caffè/té



■ 54.7378.6039  
■ 54.7378.6049

**Steakmesser\*\***

239 mm/9<sup>1</sup>/<sub>2</sub> in.  
steak knife\*\*  
couteau à steak\*\*  
cuchillo steak\*\*  
coltello da bistecca\*\*



■ 54.7309.6030  
■ 54.7309.6040

**Espresso- /  
Mokkalöffel**

108 mm/4<sup>1</sup>/<sub>4</sub> in.  
demit-tasse spoon  
cuiller à mocca  
cuchara mocha  
cucchiaio mocha



■ 54.7389.6030  
■ 54.7389.6040

**Tassenlöffel**

170 mm/6<sup>3</sup>/<sub>4</sub> in.  
round bowl soup spoon  
cuiller à bouillon  
cuchara sopa  
cucchiaio da brodo



VPE 12 Stk. / Unit 12 pcs.

- perfekte Versilberung / perfectly silverplated
- Cromargan®, poliert / stainless 18/10, polished

\* Hohlheft mit Wellenschliff / hollow-handled with serrated edge

\*\* Klingenstahl mit Wellenschliff / monobloc with serrated edge



WMF

## JUWEL 7300

■ 54 7300 6030

perfekt versilbert  
perfectly silverplated  
chromage parfait  
plateado perfecto  
perfetta placcatura in argento

■ 54 7300 6040

Cromargan®, poliert  
Cromargan®, polished  
Cromargan®, poli  
Cromargan®, pulido  
Cromargan®, lucido

■ 54.7201.6030  
■ 54.7201.6040

**Menuelöffel**

230 mm/9 in.  
table spoon  
cuiller de table  
cuchara mesa  
cucchiaio tavola



■ 54.7235.6030  
■ 54.7235.6040

**Fischgabel**

203 mm/8 in.  
fish fork  
fourchette à poisson  
tenedor pescado  
forchetta pesce



■ 54.7202.6030  
■ 54.7202.6040

**Menuegabel**

228 mm/9 in.  
table fork  
fourchette de table  
tenedor mesa  
forchetta tavola



■ 54.7236.6030  
■ 54.7236.6040

**Fischmesser**

226 mm/9 in.  
fish knife  
couteau à poisson  
cuchillo pescado  
coltello pesce



■ 54.7203.6039  
■ 54.7203.6049

**Menuemesser\*\***

246 mm/9 3/4 in.  
table knife\*\*  
couteau de table\*\*  
cuchillo mesa\*\*  
coltello tavola cutinato\*\*



■ 54.7240.6030  
■ 54.7240.6040

**Austerngabel**

149 mm/5 7/8 in.  
oyster fork  
fourchette à huîtres  
tenedor ostras  
forchetta per ostriche



■ 54.7204.6030  
■ 54.7204.6040

**Vorspeisenlöffel**

212 mm/8 1/2 in.  
dessert spoon  
cuiller à dessert  
cuchara postre  
cucchiaio frutta



■ 54.7264.6030  
■ 54.7264.6040

**Kuchengabel**

164 mm/6 1/2 in.  
cake fork  
fourchette à gâteau  
tenedor lunch  
forchetta per dolce



■ 54.7205.6030  
■ 54.7205.6040

**Vorspeisengabel**

210 mm/8 1/4 in.  
dessert fork  
fourchette à dessert  
tenedor postre  
forchetta frutta



■ 54.7266.6039  
■ 54.7266.6049

**Brot- /  
Buttermesser\*\***

170 mm/6 3/4 in.  
bread/butter knife\*\*  
couteau de table\*\*  
cuchillo mesa\*\*  
coltello per dolce\*\*



■ 54.7206.6039  
■ 54.7206.6049

**Vorspeisen-  
messer\*\***

226 mm/9 in.  
dessert knife\*\*  
cuiller à dessert\*\*  
cuchara postre\*\*  
cucchiaio frutta\*\*



■ 54.7272.6030  
■ 54.7272.6040

**Limolöffel**

220 mm/8 3/4 in.  
iced tea spoon  
cuiller à soda  
cuchara refresco  
cucchiaio bibita



■ 54.7207.6030  
■ 54.7207.6040

**Kaffeelöffel**

140 mm/5 1/2 in.  
tea/coffee spoon  
cuiller à café  
cuchara café  
cucchiaio caffè/té



■ 54.7278.6039  
■ 54.7278.6049

**Steakmesser\*\***

248 mm/9 3/4 in.  
steak knife\*\*  
couteau à steak\*\*  
cuchillo steak\*\*  
coltello da bistecca\*\*



■ 54.7209.6030  
■ 54.7209.6040

**Espresso- /  
Mokkalöffel**

110 mm/4 1/4 in.  
demi-tasse spoon  
cuiller à mocca  
cuchara moca  
cucchiaio moca



■ 54.7289.6030  
■ 54.7289.6040

**Tassenlöffel**

181 mm/7 1/4 in.  
round bowl soup spoon  
cuiller à bouillon  
cuchara sopa  
cucchiaio da brodo



■ 54.7210.6030  
■ 54.7210.6040

**Vorspeisen- /  
Dessertlöffel**

163 mm/6 1/2 in.  
coffee/tea spoon, large  
cuiller à café/thé, grande  
cuchara à café/té, grande  
cucchiaio caffè/té, grande



■ 54.7211.6030  
■ 54.7211.6040

**Gourmetlöffel**

203 mm/8 in.  
gourmet spoon  
cuiller à sauce  
cuchara salsa  
cucchiaio gourmet



VPE 12 Stk. / Unit 12 pcs.

■ perfekte Versilberung /  
perfectly silverplated

■ Cromargan®, poliert /  
stainless 18/10, polished

\*\* Klingenstahl mit Wellenschliff /  
monobloc with serrated edge





## NORDIC 7200

■ 54 7200 6030

perfekt versilbert  
perfectly silverplated  
chromage parfait  
plateado perfecto  
perfetta placcatura in argento

■ 54 7200 6040

Cromargan®, poliert  
Cromargan®, polished  
Cromargan®, poli  
Cromargan®, pulido  
Cromargan®, lucido



■ 54.1601.6030  
■ 54.1601.6040

**Menuelöffel**

213 mm/8½ in.  
table spoon  
cuiller de table  
cuchara mesa  
cucchiaio tavola



■ 54.1602.6030  
■ 54.1602.6040

**Menuegabel**

211 mm/8¼ in.  
table fork  
fourchette de table  
tenedor mesa  
forchetta tavola



■ 54.1603.6037  
■ 54.1603.6047

**Menuemesser\***

236 mm/9¼ in.  
table knife\*  
couteau de table\*  
cuchillo mesa\*  
coltello tavola cutinato\*



■ 54.1603.6039  
■ 54.1603.6049

**Menuemesser\*\*\***

236 mm/9¼ in.  
table knife\*\*\*  
couteau de table\*\*\*  
cuchillo mesa\*\*\*  
coltello tavola cutinato\*\*\*



■ 54.1604.6030  
■ 54.1604.6040

**Vorspeisenlöffel**

196 mm/7¾ in.  
dessert spoon  
cuiller à dessert  
cuchara postre  
cucchiaio frutta



■ 54.1605.6030  
■ 54.1605.6040

**Vorspeisengabel**

195 mm/7¾ in.  
dessert fork  
fourchette à dessert  
tenedor postre  
forchetta frutta



■ 54.1606.6037  
■ 54.1606.6047

**Vorspeisen-  
messer\***

217 mm/8½ in.  
dessert knife\*  
couteau à dessert\*  
cuchillo postre\*  
coltello frutta\*



■ 54.1606.6039  
■ 54.1606.6049

**Vorspeisen-  
messer\*\*\***

217 mm/8½ in.  
dessert knife\*\*\*  
couteau à dessert\*\*\*  
cuchillo postre\*\*\*  
coltello frutta\*\*\*



■ 54.1607.6030  
■ 54.1607.6040

**Kaffeelöffel**

136 mm/5¼ in.  
tea/coffee spoon  
cuiller à café  
cuchara café  
cucchiaio caffè/té



■ 54.1609.6030  
■ 54.1609.6040

**Espresso- /  
Mokkalöffel**

108 mm/4¼ in.  
demi-tasse spoon  
cuiller à mocca  
cuchara moca  
cucchiaio moca



■ 54.1610.6030  
■ 54.1610.6040

**Vorspeisen- /  
Dessertlöffel**

156 mm/6¼ in.  
coffee/tea spoon, large  
cuiller à café/thé, grande  
cuchara à café/té, grande  
cucchiaio caffè/té, grande



■ 54.1611.6030  
■ 54.1611.6040

**Gourmetlöffel**

196 mm/7¾ in.  
gourmet spoon  
cuiller à sauce  
cuchara gourmet  
cucchiaio gourmet



■ 54.1635.6030  
■ 54.1635.6040

**Fischgabel**

190 mm/7½ in.  
fish fork  
fourchette à poisson  
tenedor pescado  
forchetta pesce



■ 54.1636.6030  
■ 54.1636.6040

**Fischmesser**

214 mm/8½ in.  
fish knife  
couteau à poisson  
cuchillo pescado  
coltello pesce



■ 54.1640.6030  
■ 54.1640.6040

**Austerngabel**

149 mm/5¾ in.  
oyster fork  
fourchette à huîtres  
tenedor ostras  
forchetta per ostriche



■ 54.1664.6030  
■ 54.1664.6040

**Kuchengabel**

157 mm/6¼ in.  
cake fork  
fourchette à gâteau  
tenedor lunch  
forchetta per dolce



■ 54.1666.6039  
■ 54.1666.6049

**Brot- /  
Buttermesser\*\***

170 mm/6¾ in.  
bread/butter knife\*\*  
couteau de table\*\*  
cuchillo lunch\*\*  
coltello per dolce\*\*



■ 54.1672.6030  
■ 54.1672.6040

**Limolöffel**

220 mm/8¾ in.  
iced tea spoon  
cuiller à soda  
cuchara refresco  
cucchiaio bibita



■ 54.1678.6039  
■ 54.1678.6049

**Steakmesser\*\***

239 mm/9½ in.  
steak knife\*\*  
couteau à steak\*\*  
cuchillo steak\*\*  
coltello da bistecca\*\*



■ 54.1689.6030  
■ 54.1689.6040

**Tassenlöffel**

174 mm/6¾ in.  
round bowl soup spoon  
cuiller à bouillon  
cuchara sopa  
cucchiaio da brodo



- VPE 12 Stk. / Unit 12 pcs.
- perfekte Versilberung / perfectly silverplated
- Cromargan®, poliert / stainless 18/10, polished
- \* Hohlheft mit Wellenschliff, steht auch auf Klinge / hollow-handle with serrated edge, standing on blade optional
- \*\* Klingenstahl mit Wellenschliff / monobloc with serrated edge
- \*\*\* Klingenstahl mit Wellenschliff, steht auch auf Klinge / monobloc with serrated edge, standing on blade optional



## EPOS 1600

■ 54 1600 6030

perfekt versilbert  
 perfectly silverplated  
 chromage parfait  
 plateado perfecto  
 perfetta placcatura in argento

■ 54 1600 6040

Cromargan®, poliert  
 Cromargan®, polished  
 Cromargan®, poli  
 Cromargan®, pulido  
 Cromargan®, lucido

■ 54.9001.6030

**Menuelöffel**

■ 54.9001.6040

210 mm/8<sup>1</sup>/<sub>4</sub> in.  
table spoon  
cuiller de table  
cuchara mesa  
cucchiaio tavola

■ 54.9035.6030

**Fischgabel**

■ 54.9035.6040

179 mm/7 in.  
fish fork  
fourchette à poisson  
tenedor pescado  
forchetta pesce

■ 54.9002.6030

**Menuegabel**

■ 54.9002.6040

208 mm/8<sup>1</sup>/<sub>4</sub> in.  
table fork  
fourchette de table  
tenedor mesa  
forchetta tavola

■ 54.9036.6030

**Fischmesser**

■ 54.9036.6040

201 mm/8 in.  
fish knife  
couteau à poisson  
cuchillo pescado  
coltello pesce

■ 54.9003.6039

**Menuemesser\*\***

■ 54.9003.6049

234 mm/9<sup>1</sup>/<sub>4</sub> in.  
table knife\*\*  
couteau de table\*\*  
cuchillo mesa\*\*  
coltello tavola cutinato\*\*

■ 54.9040.6030

**Austerngabel**

■ 54.9040.6040

149 mm/5<sup>7</sup>/<sub>8</sub> in.  
oyster fork  
fourchette à huitres  
tenedor ostras  
forchetta per ostriche

■ 54.9004.6030

**Vorspeisenlöffel**

■ 54.9004.6040

190 mm/7<sup>1</sup>/<sub>2</sub> in.  
dessert spoon  
cuiller à dessert  
cuchara postre  
cucchiaio frutta

■ 54.9064.6030

**Kuchengabel**

■ 54.9064.6040

158 mm/6<sup>1</sup>/<sub>4</sub> in.  
cake fork  
fourchette à gâteau  
tenedor lunch  
forchetta per dolce

■ 54.9005.6030

**Vorspeisengabel**

■ 54.9005.6040

188 mm/7<sup>1</sup>/<sub>2</sub> in.  
dessert fork  
fourchette à dessert  
tenedor postre  
forchetta frutta

■ 54.9066.6039

**Brot- /  
Buttermesser\*\***

■ 54.9066.6049

170 mm/6<sup>3</sup>/<sub>4</sub> in.  
bread/butter knife\*\*  
couteau de table\*\*  
cuchillo lunch\*\*  
coltello per dolce\*\*

■ 54.9006.6039

**Vorspeisen-  
messer\*\***

■ 54.9006.6049

212 mm/8<sup>1</sup>/<sub>4</sub> in.  
dessert knife\*\*  
couteau à dessert\*\*  
cuchillo postre\*\*  
coltello frutta\*\*

■ 54.9072.6030

**Limolöffel**

■ 54.9072.6040

220 mm/8<sup>3</sup>/<sub>4</sub> in.  
iced tea spoon  
cuiller à soda  
cuchara refresco  
cucchiaio bibita

■ 54.9007.6030

**Kaffeelöffel**

■ 54.9007.6040

134 mm/5<sup>1</sup>/<sub>4</sub> in.  
tea/coffee spoon  
cuiller à café  
cuchara café  
cucchiaio caffè/té

■ 54.9078.6039

**Steakmesser\*\***

■ 54.9078.6049

234 mm/9<sup>1</sup>/<sub>4</sub> in.  
steak knife\*\*  
couteau à steak\*\*  
cuchillo steak\*\*  
coltello da bistecca\*\*

■ 54.9009.6030

**Espresso- /  
Mokkalöffel**

■ 54.9009.6040

108 mm/4<sup>1</sup>/<sub>4</sub> in.  
demi-tasse spoon  
cuiller à moca  
cuchara moca  
cucchiaio moca

■ 54.9089.6030

**Tassenlöffel**

■ 54.9089.6040

168 mm/6<sup>1</sup>/<sub>2</sub> in.  
round bowl soup spoon  
cuiller à bouillon  
cuchara sopa  
cucchiaio da brodo

■ 54.9010.6030

**Vorspeisen- /  
Dessertlöffel**

■ 54.9010.6040

159 mm/6<sup>1</sup>/<sub>4</sub> in.  
coffee/tea spoon, large  
cuiller à café/thé, grande  
cuchara à café/té, grande  
cucchiaio caffè/té, grande

■ 54.9011.6030

**Gourmetlöffel**

■ 54.9011.6040

190 mm/7<sup>1</sup>/<sub>2</sub> in.  
gourmet spoon  
cuiller à sauce  
cuchara gourmet  
cucchiaio gourmet

VPE 12 Stk. / Unit 12 pcs.

■ perfekte Versilberung /  
perfectly silverplated■ Cromargan®, poliert /  
stainless 18/10, polished\*\* Klingenstahl mit Wellenschliff /  
monobloc with serrated edge





## CASINO 9000

■ 54 9000 6030

perfekt versilbert  
perfectly silverplated  
chromage parfait  
plateado perfecto  
perfetta placcatura in argento

■ 54 9000 6040

Cromargan®, poliert  
Cromargan®, polished  
Cromargan®, poli  
Cromargan®, pulido  
Cromargan®, lucido



■ 10.7901.6060  
■ 12.7901.6040

**Menuelöffel**

212 mm/8<sup>1</sup>/<sub>4</sub> in.  
table spoon  
cuiller de table  
cuchara mesa  
cucchiaio tavola



■ 10.7902.6060  
■ 12.7902.6040

**Menuegabel**

210 mm/8<sup>1</sup>/<sub>4</sub> in.  
table fork  
fourchette de table  
tenedor mesa  
forchetta tavola



■ 10.7903.6067  
■ 12.7903.6047

**Menuemesser\***

246 mm/9<sup>3</sup>/<sub>4</sub> in.  
table knife\*  
couteau de table\*  
cuchillo mesa\*  
coltello tavola cutinato\*



■ 10.7903.6069  
■ 12.7903.6049

**Menuemesser\*\***

239 mm/9<sup>1</sup>/<sub>2</sub> in.  
table knife\*\*  
couteau de table\*\*  
cuchillo mesa\*\*  
coltello tavola cutinato\*\*



■ 10.7904.6060  
■ 12.7904.6040

**Vorspeisenlöffel**

190 mm/7<sup>1</sup>/<sub>2</sub> in.  
dessert spoon  
cuiller à dessert  
cuchara postre  
cucchiaio frutta



■ 10.7905.6060  
■ 12.7905.6040

**Vorspeisengabel**

188 mm/7<sup>1</sup>/<sub>2</sub> in.  
dessert fork  
fourchette à dessert  
tenedor postre  
forchetta frutta



■ 10.7906.6067  
■ 12.7906.6047

**Vorspeisen-  
messer\***

220 mm/8<sup>3</sup>/<sub>4</sub> in.  
dessert knife\*  
couteau à dessert\*  
cuchillo postre\*  
coltello frutta\*



■ 10.7906.6069  
■ 12.7906.6049

**Vorspeisen-  
messer\*\***

214 mm/8<sup>1</sup>/<sub>2</sub> in.  
dessert knife\*\*  
couteau à dessert\*\*  
cuchillo postre\*\*  
coltello frutta\*\*



■ 10.7907.6060  
■ 12.7907.6040

**Kaffeelöffel**

136 mm/5<sup>1</sup>/<sub>4</sub> in.  
tea/coffee spoon  
cuiller à café  
cuchara café  
cucchiaio caffè/té



■ 10.7909.6060  
■ 12.7909.6040

**Espresso- /  
Mokkalöffel**

108 mm/4<sup>1</sup>/<sub>4</sub> in.  
demi-tasse spoon  
cuiller à mocca  
cuchara moca  
cucchiaio moca



■ 10.7910.6060  
■ 12.7910.6040

**Vorspeisen- /  
Dessertlöffel**

159 mm/6<sup>1</sup>/<sub>4</sub> in.  
coffee/tea spoon, large  
cuiller à café/thé, grande  
cuchara à café/té, grande  
cucchiaio caffè/té, grande



■ 10.7911.6060  
■ 12.7911.6040

**Gourmetlöffel**

190 mm/7<sup>1</sup>/<sub>2</sub> in.  
gourmet spoon  
cuiller à sauce  
cuchara gourmet  
cucchiaio gourmet



■ 10.7935.6062  
■ 12.7935.6042

**Fischgabel**

188 mm/7<sup>1</sup>/<sub>2</sub> in.  
fish fork  
fourchette à poisson  
tenedor pescado  
forchetta pesce



■ 10.7935.6063  
■ 12.7935.6043

**Fischmesser**

209 mm/8<sup>1</sup>/<sub>4</sub> in.  
fish knife  
couteau à poisson  
cuchillo pescado  
coltello pesce



■ 10.7940.6060  
■ 12.7940.6040

**Austerngabel**

149 mm/5<sup>3</sup>/<sub>4</sub> in.  
oyster fork  
fourchette à huîtres  
tenedor ostras  
forchetta per ostriche



■ 10.7964.6060  
■ 12.7964.6040

**Kuchengabel**

160 mm/6<sup>1</sup>/<sub>4</sub> in.  
cake fork  
fourchette à gâteau  
tenedor lunch  
forchetta per dolce



■ 10.7966.6069  
■ 12.7966.6049

**Brot- /  
Buttermesser\*\***

170 mm/6<sup>2</sup>/<sub>4</sub> in.  
bread/butter knife\*\*  
couteau de table\*\*  
cuchillo lunch\*\*  
coltello per dolce\*\*



■ 10.7972.6060  
■ 12.7972.6040

**Limolöffel**

220 mm/8<sup>3</sup>/<sub>4</sub> in.  
iced tea spoon  
cuiller à soda  
cuchara refresco  
cucchiaio bibita



■ 10.7978.6069  
■ 12.7978.6049

**Steakmesser\*\***

235 mm/9<sup>1</sup>/<sub>4</sub> in.  
steak knife\*\*  
couteau à steak\*\*  
cuchillo steak\*\*  
coltello da bistecca\*\*



■ 10.7989.6060  
■ 12.7989.6040

**Tassenlöffel**

170 mm/6<sup>2</sup>/<sub>4</sub> in.  
round bowl soup spoon  
cuiller à bouillon  
cuchara sopa  
cucchiaio da brodo



VPE 12 Stk. / Unit 12 pcs.

- perfekte Versilberung / perfectly silverplated
- Cromargan®, poliert / stainless 18/10, polished

\* Hohlheft mit Wellenschliff / hollow-handled with serrated edge

\*\* Klingenstahl mit Wellenschliff / monobloc with serrated edge



## SOLID 7900

■ 10 7900 6060

perfekt versilbert  
perfectly silverplated  
chromage parfait  
plateado perfecto  
perfetta placcatura in argento

■ 12 7900 6040

Cromargan®, poliert  
Cromargan®, polished  
Cromargan®, poli  
Cromargan®, pulido  
Cromargan®, lucido

■ 01.0401.6060  
■ 11.0401.6040

**Menuelöffel**

203 mm/8 in.  
table spoon  
cuiller de table  
cuchara mesa  
cucchiaio tavola



■ 01.0402.6060  
■ 11.0402.6040

**Menuegabel**

201 mm/8 in.  
table fork  
fourchette de table  
tenedor mesa  
forchetta tavola



■ 01.0403.6067  
■ 11.0403.6047

**Menuemesser\***

230 mm/9 in.  
table knife\*  
couteau de table\*  
cuchillo mesa\*  
coltello tavola cutinato\*



■ 01.0403.6069  
■ 11.0403.6049

**Menuemesser\*\***

227 mm/9 in.  
table knife\*\*  
couteau de table\*\*  
cuchillo mesa\*\*  
coltello tavola cutinato\*\*



■ 01.0410.6060  
■ 11.0410.6040

**Vorspeisen- /  
Dessertlöffel**

156 mm/6 1/4 in.  
coffee/tea spoon, large  
cuiller à café/thé, grande  
cuchara à café/té, grande  
cucchiaio caffè/té grande



■ 01.0411.6060  
■ 11.0411.6040

**Gourmetlöffel**

190 mm/7 1/2 in.  
gourmet spoon  
cuiller à sauce  
cuchara gourmet  
cucchiaio gourmet



■ 01.0435.6062  
■ 11.0435.6042

**Fischgabel**

183 mm/7 1/4 in.  
fish fork  
fourchette à poisson  
tenedor pescado  
forchetta pesce



■ 01.0435.6063  
■ 11.0435.6043

**Fischmesser**

206 mm/8 in.  
fish knife  
couteau à poisson  
cuchillo pescado  
coltello pesce



■ 01.0404.6060  
■ 11.0404.6040

**Vorspeisenlöffel**

183 mm/7 1/4 in.  
dessert spoon  
cuiller à dessert  
cuchara postre  
cucchiaio frutta



■ 01.0440.6060  
■ 11.0440.6040

**Austerngabel**

145 mm/5 3/4 in.  
oyster fork  
fourchette à huîtres  
tenedor ostras  
forchetta per ostriche



■ 01.0405.6060  
■ 11.0405.6040

**Vorspeisengabel**

181 mm/7 in.  
dessert fork  
fourchette à dessert  
tenedor postre  
forchetta frutta



■ 01.0464.6060  
■ 11.0464.6040

**Kuchengabel**

157 mm/6 1/4 in.  
cake fork  
fourchette à gâteau  
tenedor lunch  
forchetta per dolce



■ 01.0406.6067  
■ 11.0406.6047

**Vorspeisen-  
messer\***

209 mm/8 1/4 in.  
dessert knife\*  
couteau à dessert\*  
cuchillo postre\*  
coltello frutta\*



■ 01.0466.6069  
■ 11.0466.6049

**Brot- /  
Buttermesser\*\***

170 mm/6 3/4 in.  
bread/butter knife\*\*  
couteau de table\*\*  
cuchillo lunch\*\*  
coltello per dolce\*\*



■ 01.0406.6069  
■ 11.0406.6049

**Vorspeisen-  
messer\*\***

205 mm/8 in.  
dessert knife\*\*  
couteau à dessert\*\*  
cuchillo postre\*\*  
coltello frutta\*\*



■ 01.0472.6060  
■ 11.0472.6040

**Limolöffel**

220 mm/8 3/4 in.  
iced tea spoon  
cuiller à soda  
cuchara refresco  
cucchiaio bibita



■ 01.0407.6060  
■ 11.0407.6040

**Kaffeelöffel**

132 mm/5 1/4 in.  
tea/coffee spoon  
cuiller à café  
cuchara café  
cucchiaio caffè/té



■ 01.0478.6069  
■ 11.0478.6049

**Steakmesser\*\***

230 mm/9 in.  
steak knife\*\*  
couteau à steak\*\*  
cuchillo steak\*\*  
coltello da bistecca\*\*



■ 01.0409.6060  
■ 11.0409.6040

**Espresso- /  
Mokkalöffel**

108 mm/4 1/4 in.  
demi-tasse spoon  
cuiller à mocca  
cuchara moca  
cucchiaio moca



■ 01.0489.6060  
■ 11.0489.6040

**Tassenlöffel**

166 mm/6 1/2 in.  
round bowl soup spoon  
cuiller à bouillon  
cuchara sopa  
cucchiaio da brodo



VPE 12 Stk. / Unit 12 pcs.

- perfekte Versilberung / perfectly silverplated
- Cromargan®, poliert / stainless 18/10, polished

\* Hohlheft mit Wellenschliff / hollow-handled with serrated edge

\*\* Klingenstahl mit Wellenschliff / monobloc with serrated edge





**BISTRO 0400**

■ 01 0400 6060

perfekt versilbert  
 perfectly silverplated  
 chromage parfait  
 plateado perfecto  
 perfetta placcatura in argento

■ 11 0400 6040

Cromargan®, poliert  
 Cromargan®, polished  
 Cromargan®, poli  
 Cromargan®, pulido  
 Cromargan®, lucido



■ 10.1901.6060

**Menuelöffel**

212 mm/8<sup>1</sup>/<sub>4</sub> in.  
table spoon  
cuiller de table  
cuchara mesa  
cucchiaio tavola



■ 10.1902.6060

**Menuegabel**

210 mm/8<sup>1</sup>/<sub>2</sub> in.  
table fork  
fourchette de table  
tenedor mesa  
forchetta tavola



■ 10.1903.6067

**Menuemesser\***

239 mm/9<sup>1</sup>/<sub>2</sub> in.  
table knife\*  
couteau de table\*  
cuchillo mesa\*  
coltello tavola cutinato\*



■ 10.1903.6069

**Menuemesser\*\***

238 mm/9<sup>1</sup>/<sub>2</sub> in.  
table knife\*\*  
couteau de table\*\*  
cuchillo mesa\*\*  
coltello tavola cutinato\*\*



■ 10.1904.6060

**Vorspeisenlöffel**

190 mm/7<sup>1</sup>/<sub>2</sub> in.  
dessert spoon  
cuiller à dessert  
cuchara postre  
cucchiaio frutta



■ 10.1905.6060

**Vorspeisengabel**

188 mm/7<sup>1</sup>/<sub>2</sub> in.  
dessert fork  
fourchette à dessert  
tenedor postre  
forchetta frutta



■ 10.1906.6067

**Vorspeisen-**

214 mm/8<sup>1</sup>/<sub>2</sub> in.  
dessert knife\*  
couteau à dessert\*  
cuchillo postre\*  
coltello frutta\*



■ 10.1906.6069

**Vorspeisen-**

213 mm/8<sup>1</sup>/<sub>2</sub> in.  
dessert knife\*\*  
couteau à dessert\*\*  
cuchillo postre\*\*  
coltello frutta\*\*



■ 10.1907.6060

**Kaffeelöffel**

136 mm/5<sup>1</sup>/<sub>2</sub> in.  
tea/coffee spoon  
cuiller à café  
cuchara café  
cucchiaio caffè/té



■ 10.1909.6060

**Espresso- /**

108 mm/4<sup>1</sup>/<sub>2</sub> in.  
demi-tasse spoon  
cuiller à mocca  
cuchara moca  
cucchiaio moca



■ 10.1910.6060

**Vorspeisen- /**

156 mm/6<sup>1</sup>/<sub>4</sub> in.  
coffee/tea spoon, large  
cuiller à café/thé grande  
cuchara à café/té, grande  
cucchiaio caffè/té, grande



■ 10.1911.6060

**Gourmetlöffel**

190 mm/7<sup>1</sup>/<sub>2</sub> in.  
gourmet spoon  
cuiller à sauce  
cuchara gourmet  
cucchiaio gourmet



■ 10.1916.6060

**Gemüselöffel**

237 mm/9<sup>1</sup>/<sub>4</sub> in.  
vegetable serving spoon  
cuiller à légumes  
cucharón legumbres  
cucchiaione servire



■ 10.1935.6062

**Fischgabel**

184 mm/7<sup>1</sup>/<sub>4</sub> in.  
fish fork  
fourchette à poisson  
tenedor pescado  
forchetta pesce



■ 10.1935.6063

**Fischmesser**

206 mm/8 in.  
fish knife  
couteau à poisson  
cuchillo pescado  
coltello pesce



■ 10.1940.6060

**Austerngabel**

149 mm/5<sup>3</sup>/<sub>4</sub> in.  
oyster fork  
fourchette à huîtres  
tenedor ostras  
forchetta per ostriche



■ 10.1964.6060

**Kuchengabel**

157 mm/6<sup>1</sup>/<sub>4</sub> in.  
cake fork  
fourchette à gâteau  
tenedor lunch  
forchetta per dolce



■ 10.1966.6069

**Brot- /**

170 mm/6<sup>3</sup>/<sub>4</sub> in.  
bread/butter knife\*\*  
couteau de table\*\*  
cuchillo mesa\*\*  
coltello per dolce\*\*



■ 10.1972.6060

**Limolöffel**

220 mm/8<sup>3</sup>/<sub>4</sub> in.  
iced tea spoon  
cuiller à soda  
cuchara refresco  
cucchiaio bibita



■ 10.1978.6069

**Steakmesser\*\***

239 mm/9<sup>1</sup>/<sub>2</sub> in.  
steak knife\*\*  
couteau à steak\*\*  
cuchillo steak\*\*  
coltello da bistecca\*\*



■ 10.1989.6060

**Tassenlöffel**

170 mm/6<sup>3</sup>/<sub>4</sub> in.  
round bowl soup spoon  
cuiller à bouillon  
cuchara sopa  
cucchiaio da brodo



VPE 12 Stk. / Unit 12 pcs.

■ perfekte Versilberung / perfectly silverplated

■ Cromargan®, poliert / stainless 18/10, polished

\* Hohlheft mit Wellenschliff / hollow-handled with serrated edge

\*\* Klingenstahl mit Wellenschliff / monobloc with serrated edge



## SIGNUM 1900

■ 10 1900 6060

perfekt versilbert  
perfectly silverplated  
chromage parfait  
plateado perfecto  
perfetta placcatura in argento

■ 12 1900 6040

Cromargan®, poliert  
Cromargan®, polished  
Cromargan®, poli  
Cromargan®, pulido  
Cromargan®, lucido

■ 10.5301.6060  
■ 12.5301.6040

**Menuelöffel**

215 mm/8½ in.  
table spoon  
cuiller de table  
cuchara mesa  
cucchiaio tavola



■ 10.5302.6060  
■ 12.5302.6040

**Menuegabel**

214 mm/8¼ in.  
table fork  
fourchette de table  
tenedor mesa  
forchetta tavola



■ 10.5303.6061  
■ 12.5303.6041

**Menuemesser\*\*\***

237 mm/9½ in.  
table knife\*\*\*  
couteau de table\*\*\*  
cuchillo mesa\*\*\*  
coltello tavola\*\*\*



■ 10.5303.6067  
■ 12.5303.6047

**Menuemesser\***

233 mm/9¼ in.  
table knife\*  
couteau de table\*  
cuchillo mesa\*  
coltello tavola cutinato\*



■ 10.5303.6069  
■ 12.5303.6049

**Menuemesser\*\***

236 mm/9¼ in.  
table knife\*\*  
couteau de table\*\*  
cuchillo mesa\*\*  
coltello tavola\*\*



■ 10.5304.6060  
■ 12.5304.6040

**Vorspeisenlöffel**

196 mm/7¾ in.  
dessert spoon  
cuiller à dessert  
cuchara postre  
cucchiaio frutta



■ 10.5305.6060  
■ 12.5305.6040

**Vorspeisengabel**

195 mm/7¾ in.  
dessert fork  
fourchette à dessert  
tenedor postre  
forchetta frutta



■ 10.5306.6061  
■ 12.5306.6041

**Vorspeisen-  
messer\*\*\***

216 mm/8½ in.  
dessert knife\*\*\*  
couteau à dessert\*\*\*  
cuchillo postre\*\*\*  
coltello frutta\*\*\*



■ 10.5306.6067  
■ 12.5306.6047

**Vorspeisen-  
messer\***

212 mm/8¼ in.  
dessert knife\*  
couteau à dessert\*  
cuchillo postre\*  
coltello frutta\*



■ 10.5306.6069  
■ 12.5306.6049

**Vorspeisen-  
messer\*\***

215 mm/8½ in.  
dessert knife\*\*  
couteau à dessert\*\*  
cuchillo postre\*\*  
coltello frutta\*\*



■ 10.5307.6060  
■ 12.5307.6040

**Kaffeelöffel**

136 mm/5¼ in.  
tea/coffee spoon  
cuiller à café  
cuchara café  
cucchiaio caffè/té



■ 10.5309.6060  
■ 12.5309.6040

**Espresso- /  
Mokkalöffel**

108 mm/4¼ in.  
demi-tasse spoon  
cuiller à moca  
cuchara moca  
cucchiaio moca



■ 10.5310.6060  
■ 12.5310.6040

**Vorspeisen- /  
Dessertlöffel**

156 mm/6¼ in.  
coffee/tea spoon, large  
cuiller à café/thé, grande  
cuchara à café/té, grande  
cucchiaio caffè/té, grande



■ 10.5311.6060  
■ 12.5311.6040

**Gourmetlöffel**

196 mm/7¾ in.  
gourmet spoon  
cuiller à sauce  
cuchara gourmet  
cucchiaio gourmet



■ 10.5366.6069  
■ 12.5366.6049

**Brot- /  
Buttermesser\*\***

170 mm/6¾ in.  
bread/butter knife\*\*  
couteau de table\*\*  
cuchillo mesa\*\*  
coltello per dolce\*\*



■ 10.5372.6060  
■ 12.5372.6040

**Limolöffel**

220 mm/8½ in.  
iced tea spoon  
cuiller à soda  
cuchara refresco  
cucchiaio bibita



■ 10.5378.6069  
■ 12.5378.6049

**Steakmesser\*\***

239 mm/9½ in.  
steak knife\*\*  
couteau à steak\*\*  
cuchillo steak\*\*  
coltello da bistecca\*\*



■ 10.5389.6060  
■ 12.5389.6040

**Tassenlöffel**

174 mm/6¾ in.  
round bowl soup spoon  
cuiller à bouillon  
cuchara sopa  
cucchiaio da brodo



■ 10.5335.6061  
■ 12.5335.6041

**Fischmesser\*\*\*\***

216 mm/8½ in.  
fish knife\*\*\*\*  
couteau à poisson\*\*\*\*  
cuchillo pescado\*\*\*\*  
coltello pesce\*\*\*\*



■ 10.5335.6062  
■ 12.5335.6042

**Fischgabel**

190 mm/7½ in.  
fish fork  
fourchette à poisson  
tenedor pescado  
forchetta pesce



■ 10.5335.6063  
■ 12.5335.6043

**Fischmesser**

215 mm/8½ in.  
fish knife  
couteau à poisson  
cuchillo pescado  
coltello pesce



■ 10.5340.6060  
■ 12.5340.6040

**Austerngabel**

149 mm/5¾ in.  
oyster fork  
fourchette à huîtres  
tenedor ostras  
forchetta per ostriche



■ 10.5364.6060  
■ 12.5364.6040

**Kuchengabel**

157 mm/6¼ in.  
cake fork  
fourchette à gâteau  
tenedor lunch  
forchetta per dolce



■ 10.5366.6061  
■ 12.5366.6041

**Brot- /  
Buttermesser\*\*\***

170 mm/6¾ in.  
bread/butter knife\*\*\*  
couteau de table\*\*\*  
cuchillo lunch\*\*\*  
coltello per dolce\*\*\*



VPE 12 Stk. / Unit 12 pcs.

■ perfekte Versilberung /  
perfectly silverplated

■ Cromargan®, poliert /  
stainless 18/10, polished

\* Hohlheft mit Wellenschliff /  
hollow-handled with serrated edge

\*\* Klingenstahl mit Wellenschliff /  
monobloc with serrated edge

\*\*\* Klingenstahl mit Wellenschliff,  
steht auch auf Klinge /  
monobloc with serrated edge,  
standing on blade optional

\*\*\*\* Klingenstahl, steht auf Klinge /  
monobloc, standing on blade optional





## UNIC 5300

■ 10 5300 6060

perfekt versilbert  
 perfectly silverplated  
 chromage parfait  
 plateado perfecto  
 perfetta placcatura in argento

■ 12 5300 6040

Cromargan®, poliert  
 Cromargan®, polished  
 Cromargan®, poli  
 Cromargan®, pulido  
 Cromargan®, lucido



■ 01.3201.6061 **Menuelöffel**

■ 11.3201.6041  
198 mm/7<sup>7</sup>/<sub>8</sub> in.  
table spoon  
cuiller de table  
cuchara mesa  
cucchiaio tavola



■ 01.3202.6061 **Menuegabel**

■ 11.3202.6041  
198 mm/7<sup>7</sup>/<sub>8</sub> in.  
table fork  
fourchette de table  
tenedor mesa  
forchetta tavola



■ 11.3202.6042 **Menuegabel, lang**

210 mm/8<sup>1</sup>/<sub>2</sub> in.  
table fork, long  
fourchette de table, longue  
tenedor mesa, de largo  
forchetta tavola, lungo



■ 01.3203.6067 **Menuemesser\***

■ 11.3203.6047  
218 mm/8<sup>5</sup>/<sub>8</sub> in.  
table knife\*  
couteau de table\*  
cuchillo mesa\*  
coltello tavola cutinato\*



■ 01.3203.6069 **Menuemesser\*\***

■ 11.3203.6049  
217 mm/8<sup>5</sup>/<sub>8</sub> in.  
table knife\*\*  
couteau de table\*\*  
cuchillo mesa\*\*  
coltello tavola cutinato\*\*



■ 01.3204.6061 **Vorspeisenlöffel**

■ 11.3204.6041  
188 mm/7<sup>3</sup>/<sub>8</sub> in.  
dessert spoon  
cuiller à dessert  
cuchara postre  
cucchiaio frutta



■ 01.3205.6061 **Vorspeisengabel**

■ 11.3205.6041  
186 mm/7<sup>3</sup>/<sub>8</sub> in.  
dessert fork  
fourchette à dessert  
tenedor postre  
forchetta frutta



■ 01.3206.6067 **Vorspeisen-**

■ 11.3206.6047 **messer\***  
205 mm/8 in.  
dessert knife\*  
couteau à dessert\*  
cuchillo postre\*  
coltello frutta\*



■ 01.3206.6069 **Vorspeisen-**

■ 11.3206.6049 **messer\*\***  
198 mm/7<sup>7</sup>/<sub>8</sub> in.  
dessert knife\*\*  
couteau à dessert\*\*  
cuchillo postre\*\*  
coltello frutta\*\*



■ 01.3207.6061 **Kaffeelöffel**

■ 11.3207.6041  
138 mm/5<sup>1</sup>/<sub>2</sub> in.  
tea/coffee spoon  
cuiller à café  
cuchara café  
cucchiaio caffè/té



■ 01.3209.6061 **Espresso- /**

■ 11.3209.6041 **Mokkalöffel**  
108 mm/4<sup>1</sup>/<sub>4</sub> in.  
demi-tasse spoon  
cuiller à mocca  
cuchara mocha  
cucchiaio mocha



■ 01.3210.6061 **Vorspeisen- /**

■ 11.3210.6041 **Dessertlöffel**  
157 mm/6<sup>1</sup>/<sub>4</sub> in.  
coffee/tea spoon, large  
cuiller à café/té, grande  
cuchara à café/té, grande  
cucchiaio caffè/té, grande



■ 01.3211.6061 **Gourmetlöffel**

■ 11.3211.6041  
188 mm/7<sup>3</sup>/<sub>8</sub> in.  
gourmet spoon  
cuiller à sauce  
cuchara gourmet  
cucchiaio gourmet



■ 01.3235.6068 **Fischgabel**

■ 11.3235.6048  
180 mm/7 in.  
fish fork  
fourchette à poisson  
tenedor pescado  
forchetta pesce



■ 01.3235.6069 **Fischmesser**

■ 11.3235.6049  
210 mm/8<sup>3</sup>/<sub>8</sub> in.  
fish knife  
couteau à poisson  
cuchillo pescado  
coltello pesce



■ 01.3264.6061 **Kuchengabel**

■ 11.3264.6041  
157 mm/6<sup>1</sup>/<sub>4</sub> in.  
cake fork  
fourchette à gâteau  
tenedor lunch  
forchetta per dolce



■ 01.3266.6069 **Brot- /**

■ 11.3266.6049 **Buttermesser\*\***  
177 mm/7 in.  
bread/butter knife\*\*  
couteau de table\*\*  
cuchillo lunch\*\*  
coltello per dolce\*\*



■ 01.3272.6061 **Limolöffel**

■ 11.3272.6041  
220 mm/8<sup>5</sup>/<sub>8</sub> in.  
iced tea spoon  
cuiller à soda  
cuchara refresco  
cucchiaio bibita



■ 01.3289.6061 **Tassenlöffel**

■ 11.3289.6041  
167 mm/6<sup>5</sup>/<sub>8</sub> in.  
round bowl soup spoon  
cuiller à bouillon  
cuchara sopa  
cucchiaio da brodo



VPE 12 Stk. / Unit 12 pcs.

■ perfekte Versilberung / perfectly silverplated

■ Cromargan®, poliert / stainless 18/10, polished

\* Hohlheft mit Wellenschliff / hollow-handled with serrated edge

\*\* Klingenstahl mit Wellenschliff / monobloc with serrated edge



## BAROCK 3200

■ 01 3200 6061

perfekt versilbert  
perfectly silverplated  
chromage parfait  
plateado perfecto  
perfetta placcatura in argento

■ 11 3200 6041

Cromargan®, poliert  
Cromargan®, polished  
Cromargan®, poli  
Cromargan®, pulido  
Cromargan®, lucido

■ 10.6201.6060  
■ 12.6201.6040

**Menuelöffel**

203 mm/8 in.  
table spoon  
cuiller de table  
cuchara mesa  
cucchiaio tavola



■ 10.6202.6060  
■ 12.6202.6040

**Menuegabel**

201 mm/8 in.  
table fork  
fourchette de table  
tenedor mesa  
forchetta tavola



■ 12.6202.6042

**Menuegabel, lang**

210 mm/8 1/2 in.  
table fork, long  
fourchette de table, longue  
tenedor mesa, largo  
forchetta tavola, lungo



■ 10.6203.6067  
■ 12.6203.6047

**Menuemesser\***

232 mm/9 1/4 in.  
table knife\*  
couteau de table\*  
cuchillo mesa\*  
coltello tavola cutinato\*



■ 10.6203.6069  
■ 12.6203.6049

**Menuemesser\*\***

229 mm/9 in.  
table knife\*\*  
couteau de table\*\*  
cuchillo mesa\*\*  
coltello tavola cutinato\*\*



■ 12.6233.6049

**Menuemesser\*\*, lang**

240 mm/9 1/2 in.  
table knife\*\*, long  
couteau de table\*\*, long  
cuchillo mesa\*\*, largo  
coltello tavola\*\*, lungo



■ 10.6204.6060  
■ 12.6204.6040

**Vorspeisenlöffel**

187 mm/7 1/2 in.  
dessert spoon  
cuiller à dessert  
cuchara postre  
cucchiaio frutta



■ 10.6205.6060  
■ 12.6205.6040

**Vorspeisengabel**

185 mm/7 1/4 in.  
dessert fork  
fourchette à dessert  
tenedor postre  
forchetta frutta



■ 10.6206.6067  
■ 12.6206.6047

**Vorspeisenmesser\***

213 mm/8 1/2 in.  
dessert knife\*  
couteau à dessert\*  
cuchillo postre\*  
coltello frutta\*



■ 10.6206.6069  
■ 12.6206.6049

**Vorspeisenmesser\*\***

213 mm/8 1/2 in.  
dessert knife\*\*  
couteau à dessert\*\*  
cuchillo postre\*\*  
coltello frutta\*\*



■ 10.6207.6060  
■ 12.6207.6040

**Kaffeelöffel**

132 mm/5 1/4 in.  
tea/coffee spoon  
cuiller à café  
cuchara café  
cucchiaio caffè/té



■ 10.6209.6060  
■ 12.6209.6040

**Espresso- / Mokkalöffel**

108 mm/4 1/4 in.  
demi-tasse spoon  
cuiller à moca  
cuchara moca  
cucchiaio moca



■ 10.6210.6060  
■ 12.6210.6040

**Vorspeisen- / Dessertlöffel**

156 mm/6 1/4 in.  
coffee/tea spoon, large  
cuiller à café/té, grande  
cuchara à café/té, grande  
cucchiaio caffè/té, grande



■ 10.6211.6060  
■ 12.6211.6040

**Gourmetlöffel**

186 mm/7 3/8 in.  
gourmet spoon  
cuiller à sauce  
cuchara gourmet  
cucchiaio gourmet



■ 10.6235.6062  
■ 12.6235.6042

**Fischgabel**

183 mm/7 1/4 in.  
fish fork  
fourchette à poisson  
tenedor pescado  
forchetta pesce



■ 10.6235.6063  
■ 12.6235.6043

**Fischmesser**

206 mm/8 in.  
fish knife  
couteau à poisson  
cuchillo pescado  
coltello pesce



■ 10.6240.6060  
■ 12.6240.6040

**Austerngabel**

138 mm/5 1/2 in.  
oyster fork  
fourchette à huîtres  
tenedor ostras  
forchetta per ostriche



■ 10.6264.6060  
■ 12.6264.6040

**Kuchengabel**

157 mm/6 1/4 in.  
cake fork  
fourchette à gâteau  
tenedor lunch  
forchetta per dolce



■ 10.6266.6069  
■ 12.6266.6049

**Brot- / Buttermesser\*\***

170 mm/6 3/4 in.  
bread/butter knife\*\*  
couteau de table\*\*  
cuchillo lunch\*\*  
coltello per dolce\*\*



■ 10.6272.6060  
■ 12.6272.6040

**Limolöffel**

220 mm/8 3/4 in.  
iced tea spoon  
cuiller à soda  
cuchara refresco  
cucchiaio bibita



■ 10.6278.6069  
■ 12.6278.6049

**Steakmesser\*\***

229 mm/9 in.  
steak knife\*\*  
couteau à steak\*\*  
cuchillo steak\*\*  
coltello da bistecca\*\*



■ 10.6289.6060  
■ 12.6289.6040

**Tassenlöffel**

166 mm/6 1/2 in.  
round bowl soup spoon  
cuiller à bouillon  
cuchara sopa  
cucchiaio da brodo



VPE 12 Stk. / Unit 12 pcs.

■ perfekte Versilberung / perfectly silverplated

■ Cromargan®, poliert / stainless 18/10, polished

\* Hohlheft mit Wellenschliff / hollow-handled with serrated edge

\*\* Klingenstahl mit Wellenschliff / monobloc with serrated edge



























## MONDIAL 6200

■ 10 6200 6060

perfekt versilbert  
perfectly silverplated  
chromage parfait  
plateado perfecto  
perfetta placcatura in argento

■ 12 6200 6040

Cromargan®, poliert  
Cromargan®, polished  
Cromargan®, poli  
Cromargan®, pulido  
Cromargan®, lucido

- |  |   |  |  |  |   |
|--|---|--|--|--|---|
| <p>■ 01.0101.6060<br/>■ 11.0101.6040</p>    | <p><b>Menuelöffel</b><br/>211 mm/8<sup>1</sup>/<sub>4</sub> in.<br/>table spoon<br/>cuiller de table<br/>cuchara mesa<br/>cucchiaio tavola</p>  | <p>■ 01.0107.6060<br/>■ 11.0107.6040</p>    | <p><b>Kaffeelöffel</b><br/>147 mm/5<sup>7</sup>/<sub>8</sub> in.<br/>tea/coffee spoon<br/>cuiller à café<br/>cuchara café<br/>cucchiaio caffè/té</p>   | <p>■ 01.0178.6067<br/>■ 11.0178.6047</p>  | <p><b>Steakmesser*</b><br/>220 mm/8<sup>5</sup>/<sub>8</sub> in.<br/>steak knife*<br/>couteau à steak*<br/>cuchillo steak*<br/>coltello da bistecca</p>       |
| <p>■ 01.0102.6060<br/>■ 11.0102.6040</p>    | <p><b>Menuegabel</b><br/>211 mm/8<sup>1</sup>/<sub>4</sub> in.<br/>table fork<br/>fourchette de table<br/>tenedor mesa<br/>forchetta tavola</p>   | <p>■ 01.0109.6060<br/>■ 11.0109.6040</p>    | <p><b>Espresso- / Mokkalöffel</b><br/>114 mm/4<sup>1</sup>/<sub>2</sub> in.<br/>demi-tasse spoon<br/>cuiller à moca<br/>cuchara moca<br/>cucchiaio moca</p>  | <p>■ 11.0178.6049</p>                     | <p><b>Steakmesser**</b><br/>234 mm/9<sup>1</sup>/<sub>4</sub> in.<br/>steak knife**<br/>couteau à steak**<br/>cuchillo steak**<br/>coltello da bistecca**</p> |
| <p>■ 01.0115.6061<br/>■ 11.0115.6041</p>    | <p><b>Menuelöffel, klein</b><br/>196 mm/7<sup>3</sup>/<sub>4</sub> in.<br/>tasting spoon, small<br/>cuiller de table, petit<br/>cuchara menu, pequeño<br/>cucchiaio menu, piccolo</p>   | <p>■ 01.0110.6060<br/>■ 11.0110.6040</p>    | <p><b>Vorspeisen- / Dessertlöffel</b><br/>165 mm/6<sup>1</sup>/<sub>2</sub> in.<br/>coffee/tea spoon, large<br/>cuiller à café/té, grande<br/>cuchara à café/té, grande<br/>cucchiaio caffè/té, grande</p> | <p>■ 01.0189.6060<br/>■ 11.0189.6040</p>  | <p><b>Tassenlöffel</b><br/>168 mm/6<sup>5</sup>/<sub>8</sub> in.<br/>round bowl soup spoon<br/>cuiller à bouillon<br/>cuchara sopa<br/>cucchiaio da brodo</p> |
| <p>■ 01.0115.6062<br/>■ 11.0115.6042</p>    | <p><b>Menuegabel, klein</b><br/>196 mm/7<sup>3</sup>/<sub>4</sub> in.<br/>tasting fork, small<br/>fourchette de table, petite<br/>tenedor menu, pequeño<br/>forchetta menu, piccolo</p> | <p>■ 01.0111.6060<br/>■ 11.0111.6040</p>    | <p><b>Gourmetlöffel</b><br/>186 mm/7<sup>3</sup>/<sub>8</sub> in.<br/>gourmet spoon<br/>cuiller à sauce<br/>cuchara gourmet<br/>cucchiaio gourmet</p>  |  |   |
| <p>■ 01.0103.6067<br/>■ 11.0103.6047</p>   | <p><b>Menuemesser*</b><br/>231 mm/9 in.<br/>table knife*<br/>couteau de table*<br/>cuchillo mesa*<br/>coltello tavola cutinato*</p>   | <p>■ 01.0135.6062<br/>■ 11.0135.6042</p>   | <p><b>Fischgabel</b><br/>179 mm/7 in.<br/>fish fork<br/>fourchette à poisson<br/>tenedor pescado<br/>forchetta pesce</p>   |  |   |
| <p>■ 01.0103.6069<br/>■ 11.0103.6049</p>  | <p><b>Menuemesser**</b><br/>231 mm/9 in.<br/>table knife**<br/>couteau de table**<br/>cuchillo mesa**<br/>coltello tavola cutinato**</p>  | <p>■ 01.0135.6063<br/>■ 11.0135.6043</p>  | <p><b>Fischmesser</b><br/>215 mm/8<sup>1</sup>/<sub>2</sub> in.<br/>fish knife<br/>couteau à poisson<br/>cuchillo pescado<br/>coltello pesce</p>   |  |   |
| <p>■ 01.0104.6060<br/>■ 11.0104.6040</p>  | <p><b>Vorspeisenlöffel</b><br/>183 mm/7<sup>1</sup>/<sub>4</sub> in.<br/>dessert spoon<br/>cuiller à dessert<br/>cuchara postre<br/>cucchiaio frutta</p>                                | <p>■ 01.0140.6060<br/>■ 11.0140.6040</p>  | <p><b>Austerngabel</b><br/>141 mm/5<sup>1</sup>/<sub>2</sub> in.<br/>oyster fork<br/>fourchette à huîtres<br/>tenedor ostras<br/>forchetta per ostriche</p>  |  |   |
| <p>■ 01.0105.6060<br/>■ 11.0105.6040</p>  | <p><b>Vorspeisengabel</b><br/>179 mm/7 in.<br/>dessert fork<br/>fourchette à dessert<br/>tenedor postre<br/>forchetta frutta</p>  | <p>■ 01.0164.6060<br/>■ 11.0164.6040</p>  | <p><b>Kuchengabel</b><br/>163 mm/6<sup>1</sup>/<sub>2</sub> in.<br/>cake fork<br/>fourchette à gâteau<br/>tenedor lunch<br/>forchetta per dolce</p>  |  |   |
| <p>■ 01.0106.6067<br/>■ 11.0106.6047</p>  | <p><b>Vorspeisenmesser*</b><br/>214 mm/8<sup>1</sup>/<sub>2</sub> in.<br/>dessert knife*<br/>couteau à dessert*<br/>cuchillo postre*<br/>coltello frutta*</p>                           | <p>■ 01.0166.6069<br/>■ 11.0166.6049</p>  | <p><b>Brot- / Buttermesser**</b><br/>170 mm/6<sup>2</sup>/<sub>8</sub> in.<br/>bread/butter knife**<br/>couteau de table**<br/>cuchillo lunch**<br/>coltello per dolce**</p>                               |  |   |
| <p>■ 01.0106.6069<br/>■ 11.0106.6049</p>  | <p><b>Vorspeisenmesser**</b><br/>214 mm/8<sup>1</sup>/<sub>2</sub> in.<br/>dessert knife**<br/>couteau à dessert**<br/>cuchillo postre**<br/>coltello frutta**</p>                      | <p>■ 01.0172.6060<br/>■ 11.0172.6040</p>  | <p><b>Limolöffel</b><br/>220 mm/8<sup>3</sup>/<sub>4</sub> in.<br/>iced tea spoon<br/>cuiller à soda<br/>cuchara refresco<br/>cucchiaio bibita</p>   |  |   |

VPE 12 Stk. / Unit 12 pcs.

■ perfekte Versilberung / perfectly silverplated

■ Cromargan®, poliert / stainless 18/10, polished

\* Hohlheft mit Wellenschliff / hollow-handled with serrated edge

\*\* Klingenstahl mit Wellenschliff / monobloc with serrated edge



## BAGUETTE 0100

■ 01 0100 6060

perfekt versilbert  
perfectly silverplated  
chromage parfait  
plateado perfecto  
perfetta placcatura in argento

■ 11 0100 6040

Cromargan®, poliert  
Cromargan®, polished  
Cromargan®, poli  
Cromargan®, pulido  
Cromargan®, lucido



■ 10.0201.6060  
■ 12.0201.6040

**Menuelöffel**

200 mm/8 in.  
table spoon  
cuiller de table  
cuchara mesa  
cucchiaio tavola



■ 10.0202.6060  
■ 12.0202.6040

**Menuegabel**

203 mm/8 in.  
table fork  
fourchette de table  
tenedor mesa  
forchetta tavola



■ 10.0203.6067  
■ 12.0203.6047

**Menuemesser\***

230 mm/9 in.  
table knife\*  
couteau de table\*  
cuchillo mesa\*  
coltello tavola cutinato\*



■ 10.0203.6069  
■ 12.0203.6049

**Menuemesser\*\***

235 mm/9 1/4 in.  
table knife\*\*  
couteau de table\*\*  
cuchillo mesa\*\*  
coltello tavola\*\*



■ 10.0204.6060  
■ 12.0204.6040

**Vorspeisenlöffel**

182 mm/7 1/4 in.  
dessert spoon  
cuiller à dessert  
cuchara postre  
cucchiaio frutta



■ 10.0205.6060  
■ 12.0205.6040

**Vorspeisengabel**

185 mm/7 1/4 in.  
dessert fork  
fourchette à dessert  
tenedor postre  
forchetta frutta



■ 10.0206.6067  
■ 12.0206.6047

**Vorspeisen-  
messer\***

211 mm/8 1/4 in.  
dessert knife\*  
couteau à dessert\*  
cuchillo postre\*  
coltello frutta\*



■ 10.0206.6069  
■ 12.0206.6049

**Vorspeisen-  
messer\*\***

211 mm/8 1/4 in.  
dessert knife\*\*  
couteau à dessert\*\*  
cuchillo postre\*\*  
coltello frutta\*\*



■ 10.0207.6060  
■ 12.0207.6040

**Kaffeelöffel**

132 mm/5 1/4 in.  
tea/coffee spoon  
cuiller à café  
cuchara café  
cucchiaio caffè/té



■ 10.0209.6060  
■ 12.0209.6040

**Espresso- /  
Mokkalöffel**

108 mm/4 1/4 in.  
demi-tasse spoon  
cuiller à mocca  
cuchara moca  
cucchiaio moca



■ 10.0210.6060  
■ 12.0210.6040

**Vorspeisen- /  
Dessertlöffel**

148 mm/5 7/8 in.  
coffee/tea spoon, large  
cuiller à café/thé, grande  
cuchara à café/té, grande  
cucchiaio caffè/té, grande



■ 10.0211.6060  
■ 12.0211.6040

**Gourmetlöffel**

190 mm/7 1/2 in.  
gourmet spoon  
cuiller à sauce  
cuchara gourmet  
cucchiaio gourmet



■ 10.0235.6062  
■ 12.0235.6042

**Fischgabel**

174 mm/6 7/8 in.  
fish fork  
fourchette à poisson  
tenedor pescado  
forchetta pesce



■ 10.0235.6063  
■ 12.0235.6043

**Fischmesser**

204 mm/8 in.  
fish knife  
couteau à poisson  
cuchillo pescado  
coltello pesce



■ 10.0240.6060  
■ 12.0240.6040

**Austerngabel**

136 mm/5 1/4 in.  
oyster fork  
fourchette à huîtres  
tenedor ostras  
forchetta per ostriche



■ 10.0264.6060  
■ 12.0264.6040

**Kuchengabel**

152 mm/6 in.  
cake fork  
fourchette à gâteau  
tenedor lunch  
forchetta per dolce



■ 10.0266.6069  
■ 12.0266.6049

**Brot- /  
Buttermesser\*\***

170 mm/6 7/8 in.  
bread/butter knife\*\*  
couteau de table\*\*  
cuchillo lunch\*\*  
coltello per dolce\*\*



■ 10.0272.6060  
■ 12.0272.6040

**Limolöffel**

220 mm/8 3/4 in.  
iced tea spoon  
cuiller à soda  
cuchara refresco  
cucchiaio bibita



■ 12.0278.6049

**Steakmesser\*\***

225 mm/8 7/8 in.  
steak knife\*\*  
couteau à steak\*\*  
cuchillo steak\*\*  
coltello da bistecca\*\*



■ 10.0289.6060  
■ 12.0289.6040

**Tassenlöffel**

169 mm/6 7/8 in.  
round bowl soup spoon  
cuiller à bouillon  
cuchara sopa  
cucchiaio da brodo



VPE 12 Stk. / Unit 12 pcs.

- perfekte Versilberung / perfectly silverplated
- Cromargan®, poliert / stainless 18/10, polished

\* Hohlheft mit Wellenschliff / hollow-handled with serrated edge

\*\* Klingenstahl mit Wellenschliff / monobloc with serrated edge

























## CONTOUR 0200

■ 10 0200 6060

perfekt versilbert  
perfectly silverplated  
chromage parfait  
plateado perfecto  
perfetta placcatura in argento

■ 12 0200 6040

Cromargan®, poliert  
Cromargan®, polished  
Cromargan®, poli  
Cromargan®, pulido  
Cromargan®, lucido

- |  |   |  |   |  |  |
|--|---|--|---|--|--|
| <p>■ 10.4801.6060<br/>■ 12.4801.6040</p>    | <p><b>Menuelöffel</b><br/>204 mm/8 in.<br/>table spoon<br/>cuiller de table<br/>cuchara mesa<br/>cucchiaio tavola</p>   | <p>■ 10.4807.6060<br/>■ 12.4807.6040</p>    | <p><b>Kaffeelöffel</b><br/>132 mm/5 1/4 in.<br/>tea/coffee spoon<br/>cuiller à café<br/>cuchara café<br/>cucchiaio caffè/té</p>   | <p>■ 12.4878.6047</p>                     | <p><b>Steakmesser*</b><br/>220 mm/8 3/4 in.<br/>steak knife*<br/>couteau à steak*<br/>cuchillo steak*<br/>coltello da bistecca*</p>      |
| <p>■ 10.4802.6060<br/>■ 12.4802.6040</p>    | <p><b>Menuegabel</b><br/>202 mm/8 in.<br/>table fork<br/>fourchette de table<br/>tenedor mesa<br/>forchetta tavola</p>  | <p>■ 10.4809.6060<br/>■ 12.4809.6040</p>    | <p><b>Espresso- / Mokkalöffel</b><br/>108 mm/4 1/4 in.<br/>demi-tasse spoon<br/>cuiller à moca<br/>cuchara moca<br/>cucchiaio moca</p>  | <p>■ 12.4878.6049</p>                     | <p><b>Steakmesser**</b><br/>228 mm/9 in.<br/>steak knife**<br/>couteau à steak**<br/>cuchillo steak**<br/>coltello da bistecca**</p>     |
| <p>■ 12.4802.6042</p>                       | <p><b>Menuegabel, lang</b><br/>210 mm/8 1/2 in.<br/>table fork, long<br/>fourchette de table, longue<br/>tenedor mesa, largo<br/>forchetta tavola, lungo</p>        | <p>■ 10.4810.6060<br/>■ 12.4810.6040</p>    | <p><b>Vorspeisen- / Dessertlöffel</b><br/>157 mm/6 1/4 in.<br/>coffee/tea spoon, large<br/>cuiller à café/té, grande<br/>cuchara à café/té, grande<br/>cucchiaio caffè/té, grande</p> | <p>■ 10.4889.6060<br/>■ 12.4889.6040</p>  | <p><b>Tassenlöffel</b><br/>166 mm/6 1/2 in.<br/>round bowl soup spoon<br/>cuiller à bouillon<br/>cuchara sopa<br/>cucchiaio da brodo</p> |
| <p>■ 10.4803.6067<br/>■ 12.4803.6047</p>    | <p><b>Menuemesser*</b><br/>226 mm/9 in.<br/>table knife*<br/>couteau de table*<br/>cuchillo mesa*<br/>coltello tavola cutinato*</p>                                 | <p>■ 10.4811.6060<br/>■ 12.4811.6040</p>    | <p><b>Gourmetlöffel</b><br/>186 mm/7 3/8 in.<br/>gourmet spoon<br/>cuiller à sauce<br/>cuchara gourmet<br/>cucchiaio gourmet</p>  |  |  |
| <p>■ 10.4803.6069<br/>■ 12.4803.6049</p>   | <p><b>Menuemesser**</b><br/>227 mm/9 in.<br/>table knife**<br/>couteau de table**<br/>cuchillo mesa**<br/>coltello tavola cutinato**</p>                            | <p>■ 10.4835.6062<br/>■ 12.4835.6042</p>   | <p><b>Fischgabel</b><br/>176 mm/7 in.<br/>fish fork<br/>fourchette à poisson<br/>tenedor pescado<br/>forchetta pesce</p>  |  |  |
| <p>■ 12.4833.6049</p>                     | <p><b>Menuemesser**, lang</b><br/>240 mm/9 1/2 in.<br/>table knife**, long<br/>couteau de table**, long<br/>cuchillo mesa**, largo<br/>coltello tavola**, lungo</p> | <p>■ 10.4835.6063<br/>■ 12.4835.6043</p>  | <p><b>Fischmesser</b><br/>198 mm/7 7/8 in.<br/>fish knife<br/>couteau à poisson<br/>cuchillo pescado<br/>coltello pesce</p>   |  |  |
| <p>■ 10.4804.6060<br/>■ 12.4804.6040</p>  | <p><b>Vorspeisenlöffel</b><br/>187 mm/7 3/8 in.<br/>dessert spoon<br/>cuiller à dessert<br/>cuchara postre<br/>cucchiaio frutta</p>                                 | <p>■ 10.4840.6060<br/>■ 12.4840.6040</p>  | <p><b>Austerngabel</b><br/>140 mm/5 1/2 in.<br/>oyster fork<br/>fourchette à huîtres<br/>tenedor ostras<br/>forchetta per ostriche</p>  |  |  |
| <p>■ 10.4805.6060<br/>■ 12.4805.6040</p>  | <p><b>Vorspeisengabel</b><br/>186 mm/7 3/8 in.<br/>dessert fork<br/>fourchette à dessert<br/>tenedor postre<br/>forchetta frutta</p>                                | <p>■ 10.4864.6060<br/>■ 12.4864.6040</p>  | <p><b>Kuchengabel</b><br/>157 mm/6 1/4 in.<br/>cake fork<br/>fourchette à gâteau<br/>tenedor lunch<br/>forchetta per dolce</p>  |  |  |
| <p>■ 10.4806.6067<br/>■ 12.4806.6047</p>  | <p><b>Vorspeisenmesser*</b><br/>212 mm/8 3/8 in.<br/>dessert knife*<br/>couteau à dessert*<br/>cuchillo postre*<br/>coltello frutta*</p>                            | <p>■ 10.4866.6069<br/>■ 12.4866.6049</p>  | <p><b>Brot- / Buttermesser**</b><br/>170 mm/6 3/4 in.<br/>bread/butter knife**<br/>couteau de table**<br/>cuchillo lunch**<br/>coltello per dolce**</p>                               |  |  |
| <p>■ 10.4806.6069<br/>■ 12.4806.6049</p>  | <p><b>Vorspeisenmesser**</b><br/>212 mm/8 3/8 in.<br/>dessert knife**<br/>couteau à dessert**<br/>cuchillo postre**<br/>coltello frutta**</p>                       | <p>■ 10.4872.6060<br/>■ 12.4872.6040</p>  | <p><b>Limolöffel</b><br/>220 mm/8 3/4 in.<br/>iced tea spoon<br/>cuiller à soda<br/>cuchara refresco<br/>cucchiaio bibita</p>   |  |  |

VPE 12 Stk. / Unit 12 pcs.

■ perfekte Versilberung / perfectly silverplated

■ Cromargan®, poliert / stainless 18/10, polished

\* Hohlheft mit Wellenschliff / hollow-handled with serrated edge

\*\* Klingenstahl mit Wellenschliff / monobloc with serrated edge





## RESIDENCE 4800

■ 10 4800 6060

perfekt versilbert  
perfectly silverplated  
chromage parfait  
plateado perfecto  
perfetta placcatura in argento

■ 12 4800 6040

Cromargan®, poliert  
Cromargan®, polished  
Cromargan®, poli  
Cromargan®, pulido  
Cromargan®, lucido

■ 10.5401.6060  
■ 12.5401.6040

**Menuelöffel**

199 mm/8 in.  
table spoon  
cuiller de table  
cuchara mesa  
cucchiaio tavola



■ 10.5402.6060  
■ 12.5402.6040

**Menuegabel**

197 mm/7 1/2 in.  
table fork  
fourchette de table  
tenedor mesa  
forchetta tavola



■ 10.5403.6067  
■ 12.5403.6047

**Menuemesser\***

216 mm/8 1/2 in.  
table knife\*  
couteau de table\*  
cuchillo mesa\*  
coltello tavola cutinato\*



■ 10.5403.6069  
■ 12.5403.6049

**Menuemesser\*\***

215 mm/8 1/2 in.  
table knife\*\*  
couteau de table\*\*  
cuchillo mesa\*\*  
coltello tavola cutinato\*\*



■ 10.5404.6060  
■ 12.5404.6040

**Vorspeisenlöffel**

187 mm/7 1/2 in.  
dessert spoon  
cuiller à dessert  
cuchara postre  
cucchiaio frutta



■ 10.5405.6060  
■ 12.5405.6040

**Vorspeisengabel**

185 mm/7 1/4 in.  
dessert fork  
fourchette à dessert  
tenedor postre  
forchetta frutta



■ 10.5406.6067  
■ 12.5406.6047

**Vorspeisen-  
messer\***

205 mm/8 in.  
dessert knife\*  
couteau à dessert\*  
cuchillo postre\*  
coltello frutta\*



■ 10.5406.6069  
■ 12.5406.6049

**Vorspeisen-  
messer\*\***

205 mm/8 in.  
dessert knife\*\*  
couteau à dessert\*\*  
cuchillo postre\*\*  
coltello frutta\*\*



■ 10.5407.6060  
■ 12.5407.6040

**Kaffeelöffel**

132 mm/5 1/4 in.  
tea/coffee spoon  
cuiller à café  
cuchara café  
cucchiaio caffè/té



■ 10.5409.6060  
■ 12.5409.6040

**Espresso- /  
Mokkalöffel**

108 mm/4 1/4 in.  
demi-tasse spoon  
cuiller à moca  
cuchara moca  
cucchiaio moca



■ 10.5410.6060  
■ 12.5410.6040

**Vorspeisen- /  
Dessertlöffel**

156 mm/6 1/4 in.  
coffee/tea spoon, large  
cuiller à café/té, grande  
cuchara à café/té, grande  
cucchiaio caffè/té, grande



■ 10.5411.6060  
■ 12.5411.6040

**Gourmetlöffel**

191 mm/7 1/2 in.  
gourmet spoon  
cuiller à sauce  
cuchara gourmet  
cucchiaio gourmet



■ 10.5435.6062  
■ 12.5435.6042

**Fischgabel**

177 mm/7 in.  
fish fork  
fourchette à poisson  
tenedor pescado  
forchetta pesce



■ 10.5435.6063  
■ 12.5435.6043

**Fischmesser**

199 mm/8 in.  
fish knife  
couteau à poisson  
cuchillo pescado  
coltello pesce



■ 10.5440.6060  
■ 12.5440.6040

**Austerngabel**

141 mm/5 1/2 in.  
oyster fork  
fourchette à huîtres  
tenedor ostras  
forchetta per ostriche



■ 10.5464.6060  
■ 12.5464.6040

**Kuchengabel**

157 mm/6 1/4 in.  
cake fork  
fourchette à gâteau  
tenedor lunch  
forchetta per dolce



■ 10.5466.6069  
■ 12.5466.6049

**Brot- /  
Buttermesser\*\***

170 mm/6 2/4 in.  
bread/butter knife\*\*  
couteau de table\*\*  
cuchillo lunch\*\*  
coltello per dolce\*\*



■ 10.5472.6060  
■ 12.5472.6040

**Limolöffel**

220 mm/8 3/4 in.  
iced tea spoon  
cuiller à soda  
cuchara refresco  
cucchiaio bibita



■ 12.5478.6047

**Steakmesser\***

222 mm/8 3/4 in.  
steak knife\*  
couteau à steak\*  
cuchillo steak\*  
coltello da bistecca\*



■ 12.5478.6049

**Steakmesser\*\***

229 mm/9 in.  
steak knife\*\*  
couteau à steak\*\*  
cuchillo steak\*\*  
coltello da bistecca\*\*



■ 10.5489.6060  
■ 12.5489.6040

**Tassenlöffel**

166 mm/6 1/2 in.  
round bowl soup spoon  
cuiller à bouillon  
cuchara sopa  
cucchiaio da brodo



VPE 12 Stk. / Unit 12 pcs.

■ perfekte Versilberung /  
perfectly silverplated

■ Cromargan®, poliert /  
stainless 18/10, polished

\* Hohlheft mit Wellenschliff /  
hollow-handled with serrated edge

\*\* Klingenstahl mit Wellenschliff /  
monobloc with serrated edge





## METROPOLITAN 5400

■ 10 5400 6060

perfekt versilbert  
perfectly silverplated  
chromage parfait  
plateado perfecto  
perfetta placcatura in argento

■ 12 5400 6040

Cromargan®, poliert  
Cromargan®, polished  
Cromargan®, poli  
Cromargan®, pulido  
Cromargan®, lucido



■ 10.1101.6060  
 ■ 12.1101.6040  
**Menuelöffel**  
 207 mm/8 1/4 in.  
 table spoon  
 cuiller de table  
 cuchara mesa  
 cucchiaio tavola



■ 10.1110.6060  
 ■ 12.1110.6040  
**Vorspeisen- /  
 Dessertlöffel**  
 156 mm/6 in.  
 coffee/tea spoon, large  
 cuiller à café/té, grande  
 cuchara à café/té, grande  
 cucchiaio caffè/té, grande



■ 10.1102.6060  
 ■ 12.1102.6040  
**Menuegabel**  
 205 mm/8 in.  
 table fork  
 fourchette de table  
 tenedor mesa  
 forchetta tavola



■ 10.1111.6060  
 ■ 12.1111.6040  
**Gourmetlöffel**  
 190 mm/7 1/2 in.  
 gourmet spoon  
 cuiller à sauce  
 cuchara gourmet  
 cucchiaio gourmet



■ 10.1103.6067  
 ■ 12.1103.6047  
**Menuemesser\***  
 237 mm/9 1/2 in.  
 table knife\*  
 couteau de table\*  
 cuchillo mesa\*  
 coltello tavola cutinato\*



■ 10.1135.6062  
 ■ 12.1135.6042  
**Fischgabel**  
 183 mm/7 1/4 in.  
 fish fork  
 fourchette à poisson  
 tenedor pescado  
 forchetta pesce



■ 10.1103.6069  
 ■ 12.1103.6049  
**Menuemesser\*\***  
 230 mm/9 in.  
 table knife\*\*  
 couteau de table\*\*  
 cuchillo mesa\*\*  
 coltello tavola cutinato\*\*



■ 10.1135.6063  
 ■ 12.1135.6043  
**Fischmesser**  
 206 mm/8 in.  
 fish knife  
 couteau à poisson  
 cuchillo pescado  
 coltello pesce



■ 10.1104.6060  
 ■ 12.1104.6040  
**Vorspeisenlöffel**  
 183 mm/7 1/4 in.  
 dessert spoon  
 cuiller à dessert  
 cuchara postre  
 cucchiaio frutta



■ 10.1140.6060  
 ■ 12.1140.6040  
**Austerngabel**  
 149 mm/5 7/8 in.  
 oyster fork  
 fourchette à huîtres  
 tenedor ostras  
 forchetta per ostriche



■ 10.1105.6060  
 ■ 12.1105.6040  
**Vorspeisengabel**  
 181 mm/7 in.  
 dessert fork  
 fourchette à dessert  
 tenedor postre  
 forchetta frutta



■ 10.1164.6060  
 ■ 12.1164.6040  
**Kuchengabel**  
 157 mm/6 1/4 in.  
 cake fork  
 fourchette à gâteau  
 tenedor lunch  
 forchetta per dolce



■ 10.1106.6067  
 ■ 12.1106.6047  
**Vorspeisen-  
 messer\***  
 214 mm/8 1/2 in.  
 dessert knife\*  
 couteau à dessert\*  
 cuchillo postre\*  
 coltello frutta\*



■ 10.1166.6069  
 ■ 12.1166.6049  
**Brot- /  
 Buttermesser\*\***  
 170 mm/6 2/4 in.  
 bread/butter knife\*\*  
 couteau de table\*\*  
 cuchillo lunch\*\*  
 coltello per dolce\*\*



■ 10.1106.6069  
 ■ 12.1106.6049  
**Vorspeisen-  
 messer\*\***  
 207 mm/8 1/4 in.  
 dessert knife\*\*  
 couteau à dessert\*\*  
 cuchillo postre\*\*  
 coltello frutta\*\*



■ 10.1172.6060  
 ■ 12.1172.6040  
**Limolöffel**  
 220 mm/8 3/4 in.  
 iced tea spoon  
 cuiller à soda  
 cuchara refresco  
 cucchiaio bibita



■ 10.1107.6060  
 ■ 12.1107.6040  
**Kaffeelöffel**  
 132 mm/5 1/4 in.  
 tea/coffee spoon  
 cuiller à café  
 cuchara café  
 cucchiaio caffè/té



■ 10.1178.6069  
 ■ 12.1178.6049  
**Steakmesser\*\***  
 226 mm/9 in.  
 steak knife\*\*  
 couteau à steak\*\*  
 cuchillo steak\*\*  
 coltello da bistecca\*\*



■ 10.1109.6060  
 ■ 12.1109.6040  
**Espresso- /  
 Mokkalöffel**  
 108 mm/4 1/4 in.  
 demi-tasse spoon  
 cuiller à moca  
 cuchara moca  
 cucchiaio moca



■ 10.1189.6060  
 ■ 12.1189.6040  
**Tassenlöffel**  
 166 mm/6 1/2 in.  
 round bowl soup spoon  
 cuiller à bouillon  
 cuchara sopa  
 cucchiaio da brodo



VPE 12 Stk. / Unit 12 pcs.

- perfekte Versilberung / perfectly silverplated
- Cromargan®, poliert / stainless 18/10, polished

\* Hohlheft mit Wellenschliff / hollow-handled with serrated edge

\*\* Klingenstahl mit Wellenschliff / monobloc with serrated edge



## FLAIR 1100

■ 10 1100 6060

perfekt versilbert  
perfectly silverplated  
chromage parfait  
plateado perfecto  
perfetta placcatura in argento

■ 12 1100 6040

Cromargan®, poliert  
Cromargan®, polished  
Cromargan®, poli  
Cromargan®, pulido  
Cromargan®, lucido

■ 11.4701.6040

**Menuelöffel**

199 mm/8 in.  
table spoon  
cuiller de table  
cuchara mesa  
cucchiaio tavola



■ 11.4702.6040

**Menuegabel**

197 mm/7 3/4 in.  
table fork  
fourchette de table  
tenedor mesa  
forchetta tavola



■ 11.4703.6047

**Menuemesser\***

217 mm/8 1/2 in.  
table knife\*  
couteau de table\*  
cuchillo mesa\*  
coltello tavola cutinato\*



■ 11.4703.6049

**Menuemesser\*\***

215 mm/8 1/2 in.  
table knife\*\*  
couteau de table\*\*  
cuchillo mesa\*\*  
coltello tavola cutinato\*\*



■ 11.4704.6040

**Vorspeisenlöffel**

183 mm/7 1/4 in.  
dessert spoon  
cuiller à dessert  
cuchara postre  
cucchiaio frutta



■ 11.4705.6040

**Vorspeisengabel**

181 mm/7 1/4 in.  
dessert fork  
fourchette à dessert  
tenedor postre  
forchetta frutta



■ 11.4706.6047

**Vorspeisen-  
messer\***

201 mm/8 in.  
dessert knife\*  
couteau à dessert\*  
cuchillo postre\*  
coltello frutta\*



■ 11.4706.6049

**Vorspeisen-  
messer\*\***

197 mm/7 3/4 in.  
dessert knife\*\*  
couteau à dessert\*\*  
cuchillo postre\*\*  
coltello frutta\*\*



■ 11.4707.6040

**Kaffeelöffel**

132 mm/5 1/4 in.  
tea/coffee spoon  
cuiller à café  
cuchara café  
cucchiaio caffè/té



■ 11.4709.6040

**Espresso- /  
Mokkalöffel**

108 mm/4 1/4 in.  
demi-tasse spoon  
cuiller à mocca  
cuchara moca  
cucchiaio moca



■ 11.4710.6040

**Vorspeisen- /  
Dessertlöffel**

156 mm/6 1/4 in.  
coffee/tea spoon, large  
cuiller à café/té, grande  
cuchara lunch  
cucchiaio caffè/té, grande



■ 11.4711.6040

**Gourmetlöffel**

186 mm/7 1/4 in.  
gourmet spoon  
cuiller à sauce  
cuchara gourmet  
cucchiaio gourmet



■ 11.4735.6042

**Fischgabel**

183 mm/7 1/4 in.  
fish fork  
fourchette à poisson  
tenedor pescado  
forchetta pesce



■ 11.4735.6043

**Fischmesser**

206 mm/8 in.  
fish knife  
couteau à poisson  
cuchillo pescado  
coltello pesce



■ 11.4740.6040

**Austerngabel**

146 mm/5 3/4 in.  
oyster fork  
fourchette à huîtres  
tenedor ostras  
forchetta per ostriche



■ 11.4764.6040

**Kuchengabel**

157 mm/6 1/4 in.  
cake fork  
fourchette à gâteau  
tenedor lunch  
forchetta per dolce



■ 11.4766.6049

**Brot- /  
Buttermesser\*\***

170 mm/6 3/4 in.  
bread/butter knife\*\*  
couteau de table\*\*  
cuchillo lunch\*\*  
coltello per dolce\*\*



■ 11.4772.6040

**Limolöffel**

220 mm/8 3/4 in.  
iced tea spoon  
cuiller à soda  
cuchara refresco  
cucchiaio bibita



■ 11.4778.6049

**Steakmesser\*\***

219 mm/8 3/4 in.  
steak knife\*\*  
couteau à steak\*\*  
cuchillo steak\*\*  
coltello da bistecca\*\*



■ 11.4789.6040

**Tassenlöffel**

166 mm/6 1/2 in.  
round bowl soup spoon  
cuiller à bouillon  
cuchara sopa  
cucchiaio da brodo



VPE 12 Stk. / Unit 12 pcs.

- Cromargan®, poliert / stainless 18/10, polished
- \* Hohlheft mit Wellenschliff / hollow-handled with serrated edge
- \*\* Klingenstahl mit Wellenschliff / monobloc with serrated edge





**CLUB 4700**

■ 11 4700 6040

Cromargan®, poliert  
Cromargan®, polished  
Cromargan®, poli  
Cromargan®, pulido  
Cromargan®, lucido

■ 54.1801.6040

**Menuelöffel**

212 mm/8<sup>1</sup>/<sub>4</sub> in.  
table spoon  
cuiller de table  
cuchara mesa  
cucchiaio tavola



■ 54.1864.6040

**Kuchengabel**

159 mm/6<sup>1</sup>/<sub>4</sub> in.  
cake fork  
fourchette à gâteau  
tenedor lunch  
forchetta per dolce



■ 54.1802.6040

**Menuegabel**

211 mm/8<sup>1</sup>/<sub>4</sub> in.  
table fork  
fourchette de table  
tenedor mesa  
forchetta tavola



■ 54.1866.6049

**Brot- /  
Buttermesser\*\***

180 mm/7 in.  
bread/butter knife\*\*  
couteau de table\*\*  
cuchillo lunch\*\*  
coltello per dolce\*\*



■ 54.1803.6049

**Menuemesser\*\***

234 mm/9<sup>1</sup>/<sub>4</sub> in.  
table knife\*\*  
couteau de table\*\*  
cuchillo mesa\*\*  
coltello tavola cutinato\*\*



■ 54.1889.6040

**Tassenlöffel**

170 mm/6<sup>3</sup>/<sub>4</sub> in.  
round bowl soup spoon  
cuiller à bouillon  
cuchara sopa  
cucchiaio da brodo



■ 54.1804.6040

**Vorspeisenlöffel**

190 mm/7<sup>1</sup>/<sub>2</sub> in.  
dessert spoon  
cuiller à dessert  
cuchara postre  
cucchiaio frutta



■ 54.1805.6040

**Vorspeisengabel**

189 mm/7<sup>1</sup>/<sub>2</sub> in.  
dessert fork  
fourchette à dessert  
tenedor postre  
forchetta frutta



■ 54.1806.6049

**Vorspeisen-  
messer\*\***

210 mm/8<sup>1</sup>/<sub>4</sub> in.  
dessert knife\*\*  
couteau à dessert\*\*  
cuchillo postre\*\*  
coltello frutta\*\*



■ 54.1807.6040

**Kaffeelöffel**

136 mm/5<sup>1</sup>/<sub>4</sub> in.  
tea/coffee spoon  
cuiller à café  
cuchara café  
cucchiaio caffè/té



■ 54.1809.6040

**Espresso- /  
Mokkalöffel**

108 mm/4<sup>1</sup>/<sub>4</sub> in.  
demi-tasse spoon  
cuiller à mocca  
cuchara moca  
cucchiaio moca



■ 54.1810.6040

**Vorspeisen- /  
Dessertlöffel**

158 mm/6<sup>1</sup>/<sub>4</sub> in.  
coffee/tea spoon, large  
cuiller à café/thé, grande  
cuchara à café/té, grande  
cucchiaio caffè/té, grande



■ 54.1836.6040

**Fischmesser**

208 mm/8<sup>1</sup>/<sub>4</sub> in.  
fish knife  
couteau à poisson  
cuchillo pescado  
coltello pesce



VPE 12 Stk. / Unit 12 pcs.

■ Cromargan®, poliert /  
stainless 18/10, polished

\*\* Klingenstahl mit Wellenschliff /  
monobloc with serrated edge



TELOS 1800

■ 54 1800 6040

Cromargan®, poliert  
Cromargan®, polished  
Cromargan®, poli  
Cromargan®, pulido  
Cromargan®, lucido



■ 12.2301.6040

**Menuelöffel**

199 mm/7<sup>7</sup>/<sub>8</sub> in.  
table spoon  
cuiller de table  
cuchara mesa  
cucchiaio tavola



■ 12.2366.6049

**Brot- /  
Buttermesser\*\***

177 mm/7 in.  
bread/butter knife\*\*  
couteau de table\*\*  
cuchillo lunch\*\*  
coltello per dolce\*\*



■ 12.2302.6040

**Menuegabel**

197 mm/7<sup>7</sup>/<sub>8</sub> in.  
table fork  
fourchette de table  
tenedor mesa  
forchetta tavola



■ 12.2389.6040

**Tassenlöffel**

166 mm/6<sup>1</sup>/<sub>2</sub> in.  
round bowl soup spoon  
cuiller à bouillon  
cuchara sopa  
cucchiaio da brodo



■ 12.2303.6049

**Menuemesser\*\***

226 mm/9 in.  
table knife\*\*  
couteau de table\*\*  
cuchillo mesa\*\*  
coltello tavola cutinato\*\*



■ 12.2304.6040

**Vorspeisenlöffel**

187 mm/7<sup>1</sup>/<sub>4</sub> in.  
dessert spoon  
cuiller à dessert  
cuchara postre  
cucchiaio frutta



■ 12.2305.6040

**Vorspeisengabel**

185 mm/7<sup>1</sup>/<sub>4</sub> in.  
dessert fork  
fourchette à dessert  
tenedor postre  
forchetta frutta



■ 12.2306.6049

**Vorspeisen-  
messer\*\***

213 mm/8<sup>1</sup>/<sub>2</sub> in.  
dessert knife\*\*  
couteau à dessert\*\*  
cuchillo postre\*\*  
coltello frutta\*\*



■ 12.2307.6040

**Kaffeelöffel**

132 mm/5<sup>1</sup>/<sub>4</sub> in.  
tea/coffee spoon  
cuiller à café  
cuchara café  
cucchiaio caffè/té



■ 12.2309.6040

**Espresso- /  
Mokkalöffel**

108 mm/4<sup>1</sup>/<sub>4</sub> in.  
demi-tasse spoon  
cuiller à mocca  
cuchara moca  
cucchiaio moca



■ 12.2310.6040

**Vorspeisen- /  
Dessertlöffel**

156 mm/6<sup>1</sup>/<sub>4</sub> in.  
coffee/tea spoon, large  
cuiller à café/thé, grande  
cuchara à café/té, grande  
cucchiaio caffè/té, grande



■ 12.2364.6040

**Kuchengabel**

157 mm/6<sup>1</sup>/<sub>4</sub> in.  
cake fork  
fourchette à gâteau  
tenedor lunch  
forchetta per dolce



VPE 12 Stk. / Unit 12 pcs.

■ Cromargan®, poliert /  
stainless 18/10, polished

\*\* Klingenstahl mit Wellenschliff /  
monobloc with serrated edge



**BASE 2300**

■ 12 2300 6040

Cromargan®, poliert  
Cromargan®, polished  
Cromargan®, poli  
Cromargan®, pulido  
Cromargan®, lucido

■ 12.0801.6040

**Menuelöffel**

195 mm/7<sup>3</sup>/<sub>4</sub> in.  
table spoon  
cuiller de table  
cuchara mesa  
cucchiaio tavola



■ 12.0810.6040

**Vorspeisen- /  
Dessertlöffel**

156 mm/6<sup>1</sup>/<sub>4</sub> in.  
coffee/tea spoon, large  
cuiller à café/thé, grande  
cuchara lunch  
cucchiaio caffè/té grande



■ 12.0802.6040

**Menuegabel**

193 mm/7<sup>1</sup>/<sub>2</sub> in.  
table fork  
fourchette de table  
tenedor mesa  
forchetta tavola



■ 12.0835.6042

**Fischgabel**

178 mm/7 in.  
fish fork  
fourchette à poisson  
tenedor pescado  
forchetta pesce



■ 12.0803.6047

**Menuemesser\***

209 mm/8<sup>1</sup>/<sub>2</sub> in.  
table knife\*  
couteau de table\*  
cuchillo mesa\*  
coltello tavola cutinato\*



■ 12.0835.6043

**Fischmesser**

205 mm/8 in.  
fish knife  
couteau à poisson  
cuchillo pescado  
coltello pesce



■ 12.0803.6049

**Menuemesser\*\***

209 mm/8<sup>1</sup>/<sub>2</sub> in.  
table knife\*\*  
couteau de table\*\*  
cuchillo mesa\*\*  
coltello tavola cutinato\*\*



■ 12.0864.6040

**Kuchengabel**

157 mm/6<sup>1</sup>/<sub>4</sub> in.  
cake fork  
fourchette à gâteau  
tenedor lunch  
forchetta per dolce



■ 12.0804.6040

**Vorspeisenlöffel**

182 mm/7<sup>1</sup>/<sub>4</sub> in.  
dessert spoon  
cuiller à dessert  
cuchara postre  
cucchiaio frutta



■ 12.0866.6049

**Brot- /  
Buttermesser\*\***

168 mm/6<sup>1</sup>/<sub>2</sub> in.  
bread/butter knife\*\*  
couteau de table\*\*  
cuchillo lunch\*\*  
coltello per dolce\*\*



■ 12.0805.6040

**Vorspeisengabel**

180 mm/7 in.  
dessert fork  
fourchette à dessert  
tenedor postre  
forchetta frutta



■ 12.0872.6040

**Limolöffel**

220 mm/8<sup>3</sup>/<sub>4</sub> in.  
iced tea spoon  
cuiller à soda  
cuchara refresco  
cucchiaio bibita



■ 12.0806.6047

**Vorspeisen-  
messer\***

195 mm/7<sup>3</sup>/<sub>4</sub> in.  
dessert knife\*  
couteau à dessert\*  
cuchillo postre\*  
coltello frutta\*



■ 12.0878.6047

**Steakmesser\***

232 mm/9<sup>1</sup>/<sub>4</sub> in.  
steak knife\*  
couteau à steak\*  
cuchillo steak\*  
coltello da bistecca\*



■ 12.0806.6049

**Vorspeisen-  
messer\*\***

195 mm/7<sup>3</sup>/<sub>4</sub> in.  
dessert knife\*\*  
couteau à dessert\*\*  
cuchillo postre\*\*  
coltello frutta\*\*



■ 12.0878.6049

**Steakmesser\*\***

232 mm/9<sup>1</sup>/<sub>4</sub> in.  
steak knife\*\*  
couteau à steak\*\*  
cuchillo steak\*\*  
coltello da bistecca\*\*



■ 12.0807.6040

**Kaffeelöffel**

132 mm/5<sup>1</sup>/<sub>4</sub> in.  
tea/coffee spoon  
cuiller à café  
cuchara café  
cucchiaio caffè/té



■ 12.0889.6040

**Tassenlöffel**

168 mm/6<sup>1</sup>/<sub>2</sub> in.  
round bowl soup spoon  
cuiller à bouillon  
cuchara sopa  
cucchiaio da brodo



■ 12.0809.6040

**Espresso- /  
Mokkalöffel**

108 mm/4<sup>1</sup>/<sub>4</sub> in.  
demi-tasse spoon  
cuiller à mocca  
cuchara moca  
cucchiaio moca



VPE 12 Stk. / Unit 12 pcs.

■ Cromargan®, poliert /  
stainless 18/10, polished

\* Hohlheft mit Wellenschliff /  
hollow-handled with serrated edge

\*\* Klingenstahl mit Wellenschliff /  
monobloc with serrated edge





**GASTRO 0800**

■ 12 0800 6040

Cromargan®, poliert  
 Cromargan®, polished  
 Cromargan®, poli  
 Cromargan®, pulido  
 Cromargan®, lucido



**Chafing Dish - Besteck**

chafing dish serving set  
service pour chafing dish  
cubierto servir chafing dish  
posate chafing dish

	Länge cm	length in.	Cromargan® stainless 18/10	versilbert silverplated
Chafing Dish Löffel / chafing dish spoon	39	15 <sup>1</sup> / <sub>4</sub>	<b>12.8387.6041</b>	<b>10.8387.6061</b>
Chafing Dish Gabel / chafing dish fork	39	15 <sup>1</sup> / <sub>4</sub>	<b>12.8387.6042</b>	<b>10.8387.6062</b>



**Salat-/Vorlegebesteck**

salad/buffet serving set  
couvert à salade/servir  
cubierto ensalada/servir  
posate servire insalata

	Länge cm	length in.	Cromargan® stainless 18/10	versilbert silverplated
Chafing Dish Löffel / chafing dish spoon	26	10 <sup>1</sup> / <sub>4</sub>	<b>12.8386.6041</b>	<b>10.8386.6061</b>
Chafing Dish Gabel / chafing dish fork	26	10 <sup>1</sup> / <sub>4</sub>	<b>12.8386.6042</b>	
Chafing Dish Gabel / chafing dish fork	26	10 <sup>1</sup> / <sub>4</sub>	<b>12.8249.6040</b>	<b>10.8249.6060</b>
Salatgabel / salad fork	26	10 <sup>1</sup> / <sub>4</sub>	<b>12.8343.6042</b>	<b>10.8343.6062</b>



**Chafing Dish - Besteck**

chafing dish serving set  
service pour chafing dish  
cubierto servir chafing dish  
posate chafing dish

Hohlheftgriff /  
hollow-handled

Cromargan® / stainless 18/10

	Länge cm	length in.	
Chafing Dish Löffel / chafing dish spoon	32,5	12 <sup>3</sup> / <sub>4</sub>	<b>12.8381.6041</b>
Chafing Dish Gabel / chafing dish fork	32,5	12 <sup>3</sup> / <sub>4</sub>	<b>12.8381.6042</b>



**Fleischgabel**

serving fork  
fourchette à viande  
tenedor carne  
forchetta da antipasto

Hohlheftgriff /  
hollow-handled

Cromargan® / stainless 18/10

Länge cm	length in.	
32,5	12 <sup>3</sup> / <sub>4</sub>	<b>12.8382.6040</b>



### Nudellöffel

pasta serving spoon  
cuillère à spaghetti  
cuchara pasta  
cuchiao per pasta

Hohlheftgriff /  
hollow-handled

Cromargan® / stainless 18/10

Länge	length
cm	in.
31,5	12 <sup>1</sup> / <sub>2</sub>

12.8383.6040



### Parmesanreibe mit Behälter

parmesan grater with storage box  
râpe à parmesan avec boîte fraîcheur  
rallador queso  
grattuggia formaggio con contenitore

Cromargan® / stainless 18/10

Länge	length
cm	in.
14	5 <sup>1</sup> / <sub>2</sub>

06.0559.6030



### Salatzange

salad serving tongs  
pince à salade  
pinza para ensalada  
pinza servire insalata

Länge	length
cm	in.
31	12 <sup>1</sup> / <sub>4</sub>

Cromargan®	versilbert
stainless 18/10	silverplated
12.8341.6040	10.8341.6060



### Salatzange

salad serving tongs  
pince à salade  
pinza para ensalada  
pinza servire insalata

Cromargan® / stainless 18/10

Länge	length
cm	in.
30,5	12

12.8306.6040





**Universalzange  
Prof. Wagenfeld**  
pastry serving tongs  
pince à gâteau  
pinza pasteles  
pinza universale

Länge	length
cm	in.
20,5	8

Cromargan® mattiert stainless 18/10, satin finished	versilbert silverplated
<b>12.8246.6030</b>	<b>10.8246.6060</b>



**Universalzange**  
pastry serving tongs  
pince à gâteau  
pinza pasteles  
pinza universale

Cromargan® / stainless 18/10

Länge	length
cm	in.
23	9

**54.9906.6040**



**Eiszange**

ice tongs  
pince à glace  
pinza hielo  
pinza per ghiaccio

Länge	length
cm	in.
17,3	6¾

Cromargan® stainless 18/10	versilbert silverplated
<b>12.8307.6040</b>	<b>10.8307.6060</b>



**Gebäck- und Servierzange**

pastry serving tongs  
pince à gâteau  
pinza pasteles  
pinza servire per dolci

Cromargan® teil mattiert / stainless 18/10 partly satin finished

Länge	length
cm	in.
17	6¾

**12.8362.6040**

### Zuckerzange

sugar tongs  
pince à sucre  
pinza de azucar  
pinza per zucchero



Länge	length
cm	in.
10,7	4 <sup>1</sup> / <sub>4</sub>

Cromargan®	versilbert
stainless 18/10	silverplated
<b>12.8342.6040</b>	<b>10.8342.6060</b>

### Hummergabel

lobster fork  
fourchette à homard  
tenedor bogavante  
forchetta aragosta



Länge	length
cm	in.
23,5	9 <sup>1</sup> / <sub>4</sub>

Cromargan®	versilbert
stainless 18/10	silverplated
<b>12.8336.6040</b>	<b>10.8336.6060</b>

### Hummerzange

lobster-crack  
pince à homard  
pinza para langostas  
pinza per aragoste



Chromstahl / chrome steel

Länge	length
cm	in.
19,8	7 <sup>3</sup> / <sub>4</sub>

**12.8410.6040**

### Schneckengabel

snail fork  
fourchette à escargots  
tenedor caracoles  
forchetta per lumache



Länge	length
cm	in.
14,5	5 <sup>3</sup> / <sub>4</sub>

Cromargan®	versilbert
stainless 18/10	silverplated
<b>12.8335.6040</b>	<b>10.8335.6060</b>

**Schneckenzange**

snail tweezer  
pince à escargots  
pinza caracoles  
pinza per lumache



Cromargan® / stainless 18/10

Länge	length
cm	in.
15	6

12.8291.6040

**Dressinglöffel**

dressing ladle  
cuiller à sauce  
cazo salsa  
mestolino salsa



Cromargan® / stainless 18/10

Länge	length	Inhalt	cap.	Ø	Ø
cm	in.	Ltr.	oz.	cm	in.
26	10 <sup>1</sup> / <sub>4</sub>	0,03	1,05	6,5	2 <sup>1</sup> / <sub>2</sub>

12.8207.6040

**Bowlenlöffel**

punch bowl ladle  
cuiller à punch  
cazo ponche  
cucchiaio per bowl



Cromargan® / stainless 18/10

Länge	length	Inhalt	cap.
cm	in.	Ltr.	oz.
40	15 <sup>3</sup> / <sub>4</sub>	0,08	2,70

12.8344.6040

**Saucenlöffel**

gravy ladle  
cuiller à sauce  
cazo salsa  
mestolino salsa



Cromargan® / stainless 18/10

Länge	length	Inhalt	cap.
cm	in.	Ltr.	oz.
18	7	0,03	1,05

12.8395.6040





### Portionsschöpfer

soup ladle, medium  
louche, medium  
cazo porciones  
ramaiolo, medio

Cromargan® / stainless 18/10

Länge	length	Inhalt	cap.
cm	in.	Ltr.	oz.
26,4	10 <sup>1</sup> / <sub>2</sub>	0,06	2,03

12.8423.6040



### Suppenschöpfer

soup ladle  
louche à potage  
cazo sopa  
ramaiolo

Cromargan® / stainless 18/10

Länge	length	Inhalt	cap.
cm	in.	Ltr.	oz.
29,5	11 <sup>1</sup> / <sub>2</sub>	0,11	3,72

54.9904.6040



### Kartoffellöffel

potato spoon  
cuiller à pommes de terre  
cucharon patatas  
cucchiaio per patate

Cromargan® / stainless 18/10

Länge	length
cm	in.
21,5	8 <sup>1</sup> / <sub>2</sub>

12.8394.6040



### Eisschaufel

ice-shovel  
cuiller à glace  
pala para hielo  
cucchianino per gelato

Cromargan® / stainless 18/10

Länge	length
cm	in.
13,8	5 <sup>1</sup> / <sub>2</sub>

12.8057.6040\*

\* VPE 12 Stk. / unit 12 pcs.



**Eierlöffel**

egg spoon  
cuiller à oeuf  
cuchara huevos  
cucchiaio per uovo

Cromargan® / stainless 18/10

Länge	length
cm	in.
13	5

12.9008.6040\*

\* VPE 12 Stk. / unit 12 pcs.



**Vorlege-/ Aufschnittgabel**

serving fork  
fourchette à viande  
tenedor carne  
forchetta da antipasto

Cromargan® / stainless 18/10

Länge	length
cm	in.
19	7½

12.8393.6040



**Brotmesser**

**GRAND GOURMET**

bread knife  
couteau à pain  
cuchillo pan  
coltello pane

Spezialklingenstahl, Cromargan® /  
special blade steel, stainless 18/10

Länge	length
cm	in.
32	12½

18.8950.6032



**Brotmesser**

**SPITZENKLASSE PLUS**

bread knife  
couteau à pain  
cuchillo pan  
coltello pane

Spezialklingenstahl, Cromargan® /  
special blade steel, stainless 18/10

Länge	length
cm	in.
31,5	12½

18.9576.6032

**Tranchiermesser  
GRAND GOURMET**

carving knife  
couteau à viande  
cuchillo carne  
coltello carne



Spezialklingenstahl, Cromargan® /  
special blade steel, stainless 18/10

Gesamtlänge cm	total length in.	Klingenlänge cm	length of blade in.
32,5	12 <sup>3</sup> / <sub>4</sub>	20	8

**18.8948.6032**

**Tranchiergabel  
GRAND GOURMET**

meat fork  
fourchette à viande  
tenedor carne  
forchettone



Cromargan® / stainless 18/10

Gesamtlänge cm	total length in.	Klingenlänge cm	length of blade in.
29	11 <sup>1</sup> / <sub>2</sub>	14	5 <sup>1</sup> / <sub>2</sub>

**18.8957.6030**

**Tranchiermesser  
SPITZENKLASSE PLUS**

carving knife  
couteau à viande  
cuchillo carne  
coltello carne



Spezialklingenstahl, Cromargan® /  
special blade steel, stainless 18/10

Gesamtlänge cm	total length in.	Klingenlänge cm	length of blade in.
32	12 <sup>1</sup> / <sub>2</sub>	20	8

**18.9582.6032**

**Tranchiergabel  
SPITZENKLASSE PLUS**

meat fork  
fourchette à viande  
tenedor carne  
forchettone



Spezialklingenstahl, Cromargan® /  
special blade steel, stainless 18/10

Gesamtlänge cm	total length in.	Klingenlänge cm	length of blade in.
27	10 <sup>3</sup> / <sub>4</sub>	12	4 <sup>3</sup> / <sub>4</sub>

**18.9588.6031**



**Steakbesteck SOLID**

steak fork and knife SOLID  
 couvert à steak SOLID  
 cubierto steak SOLID  
 posate da bistecca SOLID

Cromargan® / stainless 18/10

	Länge cm	length in.	
Steakgabel SOLID / steak fork SOLID	21	8 <sup>1</sup> / <sub>4</sub>	<b>12.9013.6040</b>
Steakmesser SOLID* / steak knife SOLID*	24,4	9 <sup>3</sup> / <sub>4</sub>	<b>12.9014.6040*</b>

\* Hohlheft mit Wellenschliff / hollow-handled with serrated edge



**Steakbesteck**

steak flatware  
 couvert à steak  
 cubierto steak  
 posate da bistecca

Cromargan® / stainless 18/10

	Länge cm	length in.	
Steakgabel / steak fork	21	8 <sup>1</sup> / <sub>4</sub>	<b>12.8960.6042</b>
Steakmesser / steak knife	23,1	9	<b>12.8960.6049</b>



**Steakmesser**

steak knife  
 couteau à steak  
 cuchillo steak  
 coltello da bistecca

Cromargan® / stainless 18/10

Länge cm	length in.	
20	8	<b>12.8705.6047</b>



**Steakmesser\***

steak knife\*  
 couteau à steak\*  
 cuchillo steak\*  
 coltello da bistecca\*

Cromargan®, poliert / stainless 18/10, polished

Länge mm	length in.	
220	8 <sup>3</sup> / <sub>4</sub>	<b>11.0178.6047</b>

\* Hohlheft mit Wellenschliff / hollow-handled with serrated edge



### Kaviarlöffel

caviar spoon  
cuiller à caviar  
cuchara caviar  
cucchiaio per caviale



versilbert / silverplated

Länge	length
cm	in.
20	8

01.0195.6062

### Kaviarmesser

caviar knife  
couteau à caviar  
cuchillo caviar  
coltellino per caviale



versilbert / silverplated

Länge	length
cm	in.
21	8 1/4

01.0195.6063

### Happy Spoon

happy spoon  
happy spoon  
happy spoon  
happy spoon



in Menue- und Vorspeisengröße! /  
in size table and dessert spoon!

Cromargan® / stainless 18/10

	Länge	length	
	cm	in.	
Happy Spoon	12,5	5	12.8993.6040
Happy Spoon S	11,5	4 1/2	12.8345.6040

\* VPE 12 Stk. / unit 12 pcs.

### Tortenheber

pie server, large  
pelle à gâteau, grande  
pala tarta, grande  
pala da torta, grande



Länge	length
cm	in.
26	10 1/4

Cromargan®	versilbert
stainless 18/10	silverplated
12.8424.6040	10.8424.6060



**Tortenmesser**

cake knife  
couteau à tarte  
cuchillo tarta  
coltello torta

Cromargan® / stainless 18/10

Länge	length
cm	in.
28	11

12.9163.6040



**Käsemesser**

cheese knife  
couteau à fromage  
cuchillo queso  
coltello formaggio

Cromargan® / stainless 18/10

Länge	length
cm	in.
22	8 <sup>3</sup> / <sub>4</sub>

12.8861.6040



**„4 for you“ - Löffel**

„4 for you“ spoon  
cuiller „4 for you“  
cuchara „4 for you“  
cucchiaio „4 for you“

Chromstahl / chrome steel

	Länge cm	length in.	
Gewürzlöffel / spicy spoon	7	2 <sup>3</sup> / <sub>4</sub>	54.9184.6040
Espressolöffel / demi-tasse spoon	10,5	4 <sup>1</sup> / <sub>4</sub>	12.9185.6040
Kaffeelöffel / coffee spoon	13,5	5 <sup>1</sup> / <sub>4</sub>	12.9186.6040
Eiskaffeelöffel / iced tea spoon	19,5	7 <sup>1</sup> / <sub>2</sub>	12.9188.6040

\* VPE 12 Stk. / unit 12 pcs.



**Löffel „KaffeeKultur“**

spoons „KaffeeKultur“  
cuillers „KaffeeKultur“  
cucharas „KaffeeKultur“  
cucchiai „KaffeeKultur“

Cromargan® / stainless 18/10

Länge	length
mm	in.
110	4 <sup>1</sup> / <sub>4</sub>
136	5 <sup>1</sup> / <sub>4</sub>
157	6 <sup>1</sup> / <sub>4</sub>

54.9901.6040

54.9902.6040

54.9903.6040

\* VPE 12 Stk. / unit 12 pcs.



### Eislöffel XL

ice spoon XL  
cuiller à glace XL  
pala para hielo XL  
cucchianino per gelato XL

Cromargan® / stainless 18/10

Länge	length
mm	in.
180	7

54.9905.6040\*

\* VPE 12 Stk. / unit 12 pcs.



### Dosenöffner

can opener  
ouvre-boîte  
abrelatas  
abriscatole

ganz Metall. Hinterlässt keine scharfen Kanten am Dosendeckel, Deckel kann wieder aufgesetzt werden. /

all metal. Does not leave sharp edges on the can lid - lid can be replaced on can.

Cromargan® / stainless 18/10

Länge	length
cm	in.
20	8

18.7319.6040



### Korkenzieher

cork-screw  
tire-bouchon  
sacacorchos  
cavatappi

Cromargan® / stainless 18/10

Länge	length
cm	in.
17,5	7

18.8252.6019



### Ess-Stäbchen Paar

#### ASIA

chopsticks pair  
baguettes paire  
juego de palillos  
paio bacchette

Cromargan®, POM Kunststoff / stainless 18/10, plastic

Länge cm	length in.
25,4	10

55.0122.6040



### Ess-Stäbchen Ablage

#### ASIA

chopstick stand  
rangement pour baguettes  
soporte para palillos  
portaoggetti per bacchette

Cromargan® / stainless 18/10

Länge cm	length in.
8,4 x 1,7 x 1	3 1/4 x 3/4 x 1/2

55.0123.6040



### Ess-Stäbchen Set

#### ASIA

chopstick set  
kit baguettes  
juego palillos  
set bacchette

bestehend aus: Ess-Stäbchen Paar, Ess-Stäbchen Ablage und  
Menselöffel Nordic /  
consisting of: chopstick pair, chopstick stand and table spoon Nordic

Cromargan®, POM Kunststoff / stainless 18/10, plastic

Ess-Stäbchen Paar / chopsticks pair

Länge cm	length in.
25,4	10

55.0122.6040

Ess-Stäbchen Ablage / chopstick stand

Länge cm	length in.
8,4 x 1,7 x 1	3 1/4 x 3/4 x 1/2

55.0123.6040

Menselöffel / table spoon

54.7201.6040

\* Artikel einzeln zu bestellen / please order articles separately



**Kinderset, 4 tlg., LILLEBI**

4-pc. child's set, LILLEBI  
couvert enfant, 4 parties, LILLEBI  
cubierto niño, 4 pzas, LILLEBI  
set per bambini, LILLEBI, 4 pz.

Cromargan® / stainless 18/10

12.9200.6040

**Kinderset, 4 tlg., SAFARI**

4-pc. child's set, SAFARI  
couvert enfant, 4 parties, SAFARI  
cubierto niño, 4 pzas, SAFARI  
set per bambini, SAFARI, 4 pz.

Cromargan® / stainless 18/10

12.8002.6040



# TABLE TOP

Getränke heiß & kalt  
beverages hot & cold

Servieren  
serving

Tischdekoration  
table decoration

Würzen  
spice it up





**Café Crème-Set**

**CultureCup**

café crème set  
 kit café crème  
 juego café-crème  
 set café crème

bestehend aus: 6 Tablett, 6 Porzellantassen M hoch, 6 Griffe M hoch,  
 6 Gläser S, 6 Kaffeelöffel /  
 consisting of: 6 serving trays, 6 porcelain cups M high, 6 handles M  
 high, 6 glasses S, 6 tea/coffee spoons

Cromargan®, Glas, Porzellan /  
 stainless 18/10, glass, porcelain

55.0111.6040



**Cappuccino-Set**

**CultureCup**

cappuccino set  
 kit cappuccino  
 juego capuchino  
 set cappuccino

bestehend aus: 6 Tablett, 6 Porzellantassen M flach, 6 Ringe M flach,  
 6 Kaffeelöffel /  
 consisting of: 6 serving trays, 6 porcelain cups M low, 6 rings M low,  
 6 tea/coffee spoons

Cromargan®, Porzellan / stainless 18/10, porcelain

55.0112.6040



**Espresso-Set**

**CultureCup**

espresso set  
 kit espresso  
 juego espresso  
 set da café espresso

bestehend aus: 6 Tablett, 6 Porzellantassen S, 6 Griffe S, 6 Gläser S,  
 6 Espresso-/Mokkalöffel /  
 consisting of: 6 serving trays, 6 porcelain cups S, 6 handles S, 6 glasses  
 S, 6 demi-tasse spoons

Cromargan®, Glas, Porzellan /  
 stainless 18/10, glass, porcelain

55.0113.6040



**Latte Macchiato-Set**

**CultureCup**

latte macchiato set  
 kit latte-macchiato  
 juego latte macchiato  
 set latte-macchiato

bestehend aus: 6 Tablett, 6 Gläser bedruckt mit „Latte“, 6 Muglöffel /  
 consisting of: 6 serving trays, 6 glasses printed with „Latte“, 6 mug  
 spoons

Cromargan®, Glas / stainless 18/10, glass

55.0116.6040



### Allround „CultureCup-Set“ (84 Teile!)

all-round „CultureCup Set“, (84 pieces!)  
 kit „CultureCup“ polyvalent, (84 pièces!)  
 juego universal para el „CultureCup“, (84 piezas!)  
 set „CultureCup“ completo, (84 pezzo!)

Das Allround-Set umfasst alles, was Sie für eine Belegung des Kaffeeumsatzes benötigen. Bestehend aus den unten aufgeführten Produkten.

The all-round set includes everything you need to boost your coffee sales. Consisting of the below listed items.

Cromargan®, Glas, Porzellan /  
 stainless 18/10, glass, porcelain

55.0117.6040

- |                           |                         |
|---------------------------|-------------------------|
| 12 Tablett                | 12 serving trays        |
| 12 Gläser S               | 12 glasses S            |
| 6 Porzellantassen M hoch  | 6 porcelain cups M high |
| 6 Porzellantassen M flach | 6 porcelain cups M low  |
| 6 Porzellantassen S       | 6 porcelain cups S      |
| 6 Griffe M hoch           | 6 handles S             |
| 6 Griffe M flach          | 6 handles M high        |
| 6 Griffe S                | 6 handles M low         |
| 6 Gläser LATTE            | 6 glasses LATTE         |
| 6 Muglöffel               | 6 mug spoons            |
| 6 Kaffeelöffel            | 6 tea/coffee spoons     |
| 6 Espressolöffel          | 6 demi-tasse spoons     |



### Tablett CultureCup

serving tray  
 plateau de service  
 bandeja  
 vassoio

Cromargan® / stainless 18/10

Größe	size
cm	in.
19,8 x 10,7 x 2	7 <sup>3</sup> / <sub>4</sub> x 4 <sup>1</sup> / <sub>4</sub> x 3 <sup>1</sup> / <sub>4</sub>

55.0115.6040



### Glas LATTE (VPE 6 Stk.)

glass LATTE (unit 6 pcs.)  
 verre LATTE (UV 6 pc.)  
 vaso LATTE (UV 6 p.)  
 bicchiere LATTE (UV 6 p.)

Gläser bedruckt mit „LATTE“ /  
 glasses printed with „LATTE“

Höhe	height	Inhalt	cap.	Ø	Ø	
cm	in.	Ltr.	oz.	cm	in.	
14,5	5 <sup>3</sup> / <sub>4</sub>	0,35	11,8	6,5	2 <sup>1</sup> / <sub>2</sub>	55.0092.9990





**Porzellantasse M hoch mit Griff**  
**CultureCup**

porcelain cup M high with handle  
tasse en porcelaine M haute avec anse  
taza de procelana M alta con asa  
tassa di porcellana M alta con maniglia

Cromargan®, Porzellan / stainless 18/10, porcelain

Höhe	height	Inhalt	cap.
cm	in.	Ltr.	oz.
8,7	3 1/2	0,21	7,1

Porzellantasse M hoch (VPE 6 Stk.) /  
porcelain cup M high (unit 6 pcs.)

55.0111.9805

Griff M hoch / handle M high

55.0111.6042

\* Artikel einzeln bestellen / please order articles separately



**Porzellantasse M flach mit Griff**  
**CultureCup**

porcelain cup M low with handle  
tasse en porcelaine M plate avec anse  
taza de procelana M baja con asa  
tassa di porcellana M bassa con maniglia

Cromargan®, Porzellan / stainless 18/10, porcelain

Höhe	height	Inhalt	cap.
cm	in.	Ltr.	oz.
7,5	3	0,25	8,5

Porzellantasse M flach (VPE 6 Stk.) /  
porcelain cup M low (unit 6 pcs.)

55.0112.9805

Griff M flach / handle M low

55.0112.6042

\* Artikel einzeln bestellen / please order articles separately



**Porzellantasse S mit Griff**  
**CultureCup**

porcelain cup S with handle  
tasse en porcelaine S avec anse  
taza de procelana S con asa  
tassa di porcellana S con maniglia

Cromargan®, Porzellan / stainless 18/10, porcelain

Höhe	height	Inhalt	cap.
cm	in.	Ltr.	oz.
6,9	2 3/4	0,08	2,7

Porzellantasse S (VPE 6 Stk.) / porcelain cup S (unit 6 pcs.)

55.0113.9805

Griff S / handle S

55.0113.6042

\* Artikel einzeln bestellen / please order articles separately



**Glas S (VPE 6 Stk.)**  
**CultureCup**

glass S (unit 6 pcs.)  
verre S (UV 6 pc.)  
vaso S (UV 6 p.)  
bicchiere S (UV 6 p.)

nicht kombinierbar mit: Deckel mit Ausschnitt 55.0031.6040 /  
not combinable with: lid with cut-out 55.0031.6040

Glas / glass

Höhe	height	Inhalt	cap.
cm	in.	Ltr.	oz.
7	2 3/4	0,09	3

55.0114.9995

### Löffel „CultureCup“

spoons „CultureCup“  
cuillers „CultureCup“  
cucharas „CultureCup“  
cucchiai „CultureCup“



Cromargan® / stainless 18/10

Länge	length
mm	in.
110	4 <sup>1</sup> / <sub>4</sub>
136	5 <sup>1</sup> / <sub>4</sub>
157	6 <sup>1</sup> / <sub>4</sub>

54.9901.6040

54.9902.6040

54.9903.6040

\* VPE 12 Stk. / unit 12 pcs.

### Deckel mit Ausschnitt

lid with cut-out  
couvercle avec découpe  
tapa con recorte  
coperchio con punto aperto per cucchiaio



passend zu Glas S, Porzellantasse S, Sahnekännchen von KaffeeKultur und Porzellantasse S von CultureCup. / fitting for glass S, porcelain cup S, creamer of CoffeeCulture and porcelain cup S of CultureCup.

Cromargan® / stainless 18/10

Ø	Ø
cm	in.
6	2 <sup>1</sup> / <sub>4</sub>

55.0031.6040

### Porzellanbehälter CultureCup

porcelain dish  
récipient en porcelaine  
recipiente de porcelana  
recipiente di porcellana



passend in Pure Exclusiv Einsätze und zu Deckel mit Ausschnitt / fitting in inserts Pure Exclusiv and to lid with cut-out

Cromargan®, Porzellan / stainless 18/10, porcelain

Höhe	height	Inhalt	cap.
cm	in.	Ltr.	oz.
6,6	2 <sup>1</sup> / <sub>2</sub>	0,08	2,7

Porzellantasse S (VPE 6 Stk.) / porcelain cup S (unit 6 pcs.) 55.0113.9805

Deckel mit Ausschnitt / lid with cut-out 55.0031.6040

Espresso-/Mokkalöffel / demi-tasse spoon 54.9901.6040

\* Artikel einzeln bestellen / please order articles separately



**Latte Macchiato-Set**

**KaffeeKultur**

latte macchiato set  
kit latte-macchiato  
juego latte macchiato  
set latte-macchiato

bestehend aus: 6 Tablett, 6 Gläser L bedruckt mit „Latte Macchiato“,  
6 Ringe L, 6 Muglöffel /  
consisting of: 6 serving trays, 6 glasses L printed with „Latte  
Macchiato“, 6 rings L, 6 mug spoons

Cromargan®, Glas / stainless 18/10, glass

06.2516.6040



**Milchkaffee-Set**

**KaffeeKultur**

caffè Latte set  
kit café au lait  
juego café con leche  
set café latte

bestehend aus: 6 Tablett, 6 Gläser L unbedruckt, 6 Griffe L,  
6 Muglöffel /  
consisting of: 6 serving trays, 6 glasses L unprinted, 6 handles L,  
6 mug spoons

Cromargan®, Glas / stainless 18/10, glass

06.2519.6040



**Espresso-Set**

**KaffeeKultur**

espresso set  
kit espresso  
juego espresso  
set da café espresso

bestehend aus: 6 Tablett, 6 Porzellantassen S, 6 Griffe S, 6 Gläser S,  
6 Ringe S, 6 Espresso-/Mokkalöffel /  
consisting of: 6 serving trays, 6 porcelain cups S, 6 handles S, 6 glasses  
S, 6 rings S, 6 demi-tasse spoons

Cromargan®, Glas, Porzellan /  
stainless 18/10, glass, porcelain

06.2518.6040



**Café Crème-Set**

**KaffeeKultur**

café crème set  
kit café crème  
juego café-crème  
set café crème

bestehend aus: 6 Tablett, 6 Porzellantassen M, 6 Griffe M, 6 Gläser S,  
6 Ringe S, 6 Kaffeelöffel /  
consisting of: 6 serving trays, 6 porcelain cups M, 6 handles M,  
6 glasses S, 6 rings S, 6 tea/coffee spoons

Cromargan®, Glas, Porzellan /  
stainless 18/10, glass, porcelain

06.2517.6040



### Café au Lait-Set KaffeeKultur

café au lait set  
kit café au lait  
juego café con leche  
set café au lait



bestehend aus: 6 Tablettts, 6 Milchkaffeeschalen, 6 Ringe XL,  
6 Muglöffel /  
consisting of: 6 serving trays, 6 milk coffee pots, 6 rings XL, 6 mug  
spoons

Cromargan®, Porzellan / stainless 18/10, porcelain **06.2527.6040**

### Doppel-Espresso-Set KaffeeKultur

espresso double set  
kit espresso double  
juego espresso doble  
set café espresso doppio



bestehend aus: 6 Tablettts, 6 Doppel-Espresso-Tassen, 6 Griffe S,  
6 Gläser S, 6 Ringe S, 6 Espressolöffel /  
consisting of: 6 serving trays, 6 cups Espresso double, 6 handles S,  
6 glasses S, 6 rings S, 6 demi-tasse spoons

Cromargan®, Glas, Porzellan /  
stainless 18/10, glass, porcelain

**55.0043.6040**

### Allround „KaffeeKultur-Set“ (über 100 Teile!)

all-round „KaffeeKultur Set“, (over 100 pieces!)  
kit „KaffeeKultur“ polyvalent, (plus de 100 pièces!)  
juego universal para el „KaffeeKultur“, (más de 100 piezas!)  
set „KaffeeKultur“ completo, (più di 100 pezzi!)

Das Allround-Set umfasst alles, was Sie für eine Belegung des Kaffeeumsatzes benötigen. Bestehend aus den unten aufgeführten Produkten.

The all-round set includes everything you need to boost your coffee sales. Consisting of the below listed items.

Cromargan®, Glas, Porzellan /  
stainless 18/10, glass, porcelain

**06.2520.6040**

- |                         |                         |
|-------------------------|-------------------------|
| 12 Tablettts            | 12 serving trays        |
| 6 Gläser L (bedruckt)   | 6 glasses L (printed)   |
| 6 Gläser L (unbedruckt) | 6 glasses L (unprinted) |
| 12 Gläser S             | 12 glasses S            |
| 6 Porzellantassen M     | 6 porcelain cups M      |
| 6 Porzellantassen S     | 6 porcelain cups S      |
| 6 Ringe L               | 6 rings L               |
| 12 Ringe S              | 12 rings S              |
| 6 Griffe L              | 6 handles L             |
| 6 Griffe M              | 6 handles M             |
| 6 Griffe S              | 6 handles S             |
| 6 Muglöffel             | 6 mug spoons            |
| 6 Kaffeelöffel          | 6 tea/coffee spoons     |
| 6 Espressolöffel        | 6 demi-tasse spoons     |



**Einzelartikel „KaffeeKultur“**

single items „KaffeeKultur“

articles isolés „KaffeeKultur“

artículos diversos „KaffeeKultur“

singolo articolo „KaffeeKultur“

Cromargan®, Glas, Porzellan / stainless 18/10, glass, porcelain



①

① Tablett / serving tray

Größe	size	
cm	in.	
18,8 x 12 x 2	7 1/2 x 4 3/4 x 3/4	<b>06.2500.6040</b>



②



③



④

② Glas L bedruckt (VPE 6 Stk.) / glass L printed (unit 6 pcs.)

Höhe	height	Inhalt	cap.
cm	in.	Ltr.	oz.
11,6	4 1/2	0,32	10,8

③ Glas L unbedruckt (VPE 6 Stk.) / glass L unprinted (unit 6 pcs.)

Höhe	height	Inhalt	cap.
cm	in.	Ltr.	oz.
11,6	4 1/2	0,32	10,8

④ Glas S (VPE 6 Stk.) / glass S (unit 6 pcs.)

Höhe	height	Inhalt	cap.
cm	in.	Ltr.	oz.
7,4	3	0,1	3,4

⑤ Milchkaffeeschale (VPE 6 Stk.) / milk coffee pot (unit 6 pcs.)

Höhe	height	Inhalt	cap.
cm	in.	Ltr.	oz.
9,6	3 3/4	0,4	13,5

⑥ Porzellantasse M (VPE 6 Stk.) / porcelain cup M (unit 6 pcs.)

Höhe	height	Inhalt	cap.
cm	in.	Ltr.	oz.
9,6	3 3/4	0,25	8,5

⑦ Doppel-Espressotasse (VPE 6 Stk.) / Espresso cup double (unit 6 pcs.)

Höhe	height	Inhalt	cap.	Ø	Ø
cm	in.	Ltr.	oz.	cm	in.
8,4	3 1/4	0,13	4,4	6,2	2 1/2

⑧ Porzellantasse S (VPE 6 Stk.) / porcelain cup S (unit 6 pcs.)

Höhe	height	Inhalt	cap.
cm	in.	Ltr.	oz.
7,4	3	0,1	3,4

⑨ Ring XL / ring XL  
passend auf Milchkaffeeschale /  
fitting on milk coffee pot

**06.2525.6040**

⑩ Ring L / ring L  
passend auf Glas L / fitting on glass L

**06.2501.6040**

⑪ Ring S / ring S  
passend auf Glas S, Tasse S, Doppel-Espresso-Tasse  
und Sahnekännchen von KaffeeKultur /  
fitting on glass S, cup S, Espresso double cup and  
creamer of CoffeeCulture

**06.2502.6040**

⑫ Griff L / handle L  
passend auf Glas L / fitting on glass L

**06.2503.6040**

⑬ Griff M / handle M  
passend auf Porzellantasse M /  
fitting on porcelain cup M

**06.2504.6040**

⑭ Griff S / handle S  
passend auf Glas S, Porzellantasse S, Doppel-  
Espressotasse und Sahnekännchen von KaffeeKultur /  
fitting on glass S, porcelain cup S, Espresso cup  
double and creamer of CoffeeCulture

**06.2509.6040**

⑮ Muglöffel / mug spoon

Länge	length
mm	in.
157	6 1/4

**54.9903.6040**

⑯ Kaffeelöffel / tea/coffee spoon

Länge	length
mm	in.
136	5 1/4

**54.9902.6040**

⑰ Espresso-/Mokkalöffel / demi-tasse spoon

Länge	length
mm	in.
110	4 1/4

**54.9901.6040**



⑤



⑥



⑦



⑧



⑨



⑩



⑪



⑫



⑬



⑭



⑮



⑯



⑰



### Sahne-/Zucker-Set KaffeeKultur

sugar and milk set  
service pots à lait / sucriers  
juego azucarero / cremera  
set lattiera zuccheriera

bestehend aus: Tablett, Sahnekännchen und Zuckerbehälter. /  
consisting of: serving tray, creamer and sugar bowl.

Cromargan®, Porzellan / stainless 18/10, porcelain

Tablett / serving tray

Größe cm	size in.	
18,8 x 12 x 2	7 <sup>1</sup> / <sub>2</sub> x 4 <sup>3</sup> / <sub>4</sub> x 3 <sup>3</sup> / <sub>4</sub>	<b>06.2500.6040</b>

Sahnekännchen (VPE 6 Stk.) / creamer (unit 6 pcs.)

Höhe cm	height in.	Inhalt Ltr.	cap. oz.	
7	2 <sup>3</sup> / <sub>4</sub>	0,1	3,4	<b>55.0033.9990</b>

Griff S / handle S **06.2509.6040**

Porzellantasse S (VPE 6 Stk.) / porcelain cup S (unit 6 pcs.)

Höhe cm	height in.	Inhalt Ltr.	cap. oz.	
7,4	3	0,1	3,4	<b>60.2508.9990</b>

Ring S / ring S **06.2502.6040**

Deckel mit Ausschnitt / lid with cut-out **55.0031.6040**

Espresso-/Mokkalöffel / demi-tasse spoon **54.9901.6040**

\* Artikel einzeln bestellen / please order articles separately



### Deckel mit Ausschnitt

lid with cut-out  
couvercle avec découpe  
tapa con recorte  
coperchio con punto aperto per cucchiaino

passend zu Glas S, Porzellantasse S, Sahnekännchen von KaffeeKultur  
und Porzellantasse S von CultureCup. /  
fitting for glass S, porcelain cup S, creamer of CoffeeCulture and  
porcelain cup S of CultureCup.

Cromargan® / stainless 18/10

Ø cm	Ø in.	
6	2 <sup>1</sup> / <sub>4</sub>	<b>55.0031.6040</b>



**Sahnekännchen (VPE 6 Stk.)**

**KaffeeKultur**

creamer (unit 6 pcs.)  
 crémier (UV 6 pc.)  
 cremera (UV 6 p.)  
 bricchetto per il latte (UV 6 p.)

kombinierbar mit Ring S, Griff S von KaffeeKultur und Deckel mit Ausschnitt /  
 to be combined with ring S, handle S CoffeeCulture and lid with cut-out

Porzellan / porcelain

Höhe	height	Inhalt	cap.	
cm	in.	Ltr.	oz.	
7	2¾	0,1	3,4	<b>55.0033.9990</b>

Zubehör / accessory:

Ring S / ring S	06.2502.6040
Griff S / handle S	06.2509.6040
Deckel mit Ausschnitt / lid with cut-out	55.0031.6040



**Sahnekännchen, mit Deckel**

**KaffeeKultur**

creamer, with lid  
 crémier, avec couvercle  
 cremera, con tapa  
 bricchetto per il latte, con coperchio

Cromargan®, Porzellan / stainless 18/10, porcelain

Sahnekännchen (VPE 6 Stk.) / creamer (unit 6 pcs.)

Höhe	height	Inhalt	cap.	
cm	in.	Ltr.	oz.	
7	2¾	0,1	3,4	<b>55.0033.9990</b>

Griff S / handle S **06.2509.6040**

Deckel mit Ausschnitt / lid with cut-out **55.0031.6040**

\* Artikel einzeln bestellen / please order articles separately



**Porzellanbehälter**

**KaffeeKultur**

porcelain dish  
 récipient en porcelaine  
 recipiente de porcelana  
 recipiente di porcellana

für Zucker, Marmelade, Senf u.a. /  
 for sugar, jam, mustard ...

Cromargan®, Porzellan / stainless 18/10, porcelain

Porzellantasse S (VPE 6 Stk.) / porcelain cup S (unit 6 pcs.)

Höhe	height	Inhalt	cap.	
cm	in.	Ltr.	oz.	
7,4	3	0,1	3,4	<b>60.2508.9990</b>

Ring S / ring S **06.2502.6040**

Deckel mit Ausschnitt / lid with cut-out **55.0031.6040**

Espresso-/Mokkalöffel / demi-tasse spoon **54.9901.6040**

\* Artikel einzeln bestellen / please order articles separately





**Glasbehälter  
KaffeeKultur**

glass dish  
 récipient en verre  
 recipiente de cristal  
 recipiente di vetro

für Zucker, Marmelade, Senf u.a. /  
 for sugar, jam, mustard ...

Cromargan®, Glas / stainless 18/10, glass

Glas S (VPE 6 Stk.) / glass S (unit 6 pcs.)

Höhe	height	Inhalt	cap.	
cm	in.	Ltr.	oz.	
7,4	3	0,1	3,4	<b>60.2506.9990</b>

Ring S / ring S **06.2502.6040**

Deckel mit Ausschnitt / lid with cut-out **55.0031.6040**

Espresso-/Mokkalöffel / demi-tasse spoon **54.9901.6040**

**\* Artikel einzeln bestellen / please order articles separately**



**Latte Macchiato-Set**

Latte Macchiato Set  
latte-macchiato-set  
juego latte macchiato  
set latte-macchiato

12er Set bestehend aus:  
12 x Glas, 12 x Löffel, 12 x Unterteller (Durchm. 12 cm) /  
set of 12 pcs. consisting of:  
12 x glass, 12 x spoon, 12 x underliner (dia. 4<sup>3</sup>/<sub>4</sub> in.)

Cromargan®, Glas / stainless 18/10, glass

Inhalt	cap.
Ltr.	oz.
0,3	10,5

**06.3172.6040**

Ersatzteil / spare part:

Eiskaffeelöffel / iced tea spoon

12.9188.6040

6er Set Gläser / 6 glasses

19.9999.8667



**Gläser-Set, Iced Coffee-Set**

glass set, iced coffee set  
set à glass  
juego vasos  
set da bicchieres

6er Set bestehend aus: 6 x Glas, 6 x Löffel, 6 x Tablett (18,8 x 12 cm) /  
set of 6 pcs. consisting of: 6 x glass, 6 x spoon, 6 x serving tray (18,8 x  
12 cm / 7 1/2 x 4 3/4 in.)

Cromargan®, Glas / stainless 18/10, glass

**55.0090.6040**

Ersatzteil / spare part:

Ersatzglas, (6 St.) / spare glasses, (6 pcs.)

55.0089.9990

Inhalt	cap.
Ltr.	oz.
0,3	10,5

Tablett / serving tray

06.2500.6040

Muglöffel / mug spoon

54.9903.6040



**Teeglas**

**PURE**

tea glass  
verre à thé  
vaso té  
bicchiere da té

Cromargan®, Glas / stainless 18/10, glass

Höhe	height	Inhalt	cap.	Ø	Ø
cm	in.	Ltr.	oz.	cm	in.
9	3 1/2	0,2	6,76	6,5	2 1/2

**06.3565.6040**

Ersatzteil / spare part:

Glaseinsatz / glass insert

60.3147.9990



### Teesieb-Behälter

tea strainer holder  
soucoupe pour passoire à thé  
recipiente colador té  
contenitore per colino tè

für Teesieb-Einsatz 06.3428.6030 /  
fitting for tea strainer insert 06.3428.6030

Porzellan, weiß / porcelain, white

Höhe	height	Ø	Ø
cm	in.	cm	in.
8	3 <sup>1</sup> / <sub>4</sub>	5	2

**60.3039.9990**



### Teesieb-Einsatz

tea strainer insert  
passoire à thé  
interior colador té  
colino per tè

passend in alle WMF-Teekannen /  
fitting in all WMF tea pots

Cromargan® / stainless 18/10

Höhe	height	Ø	Ø
cm	in.	cm	in.
7	2 <sup>3</sup> / <sub>4</sub>	5	2

**06.3428.6030**



### Teesieb, mit Abtropfschale

tea strainer, with bowl  
passoire, avec réceptacle à thé  
recipiente colador, de té con bandejita escurridora  
colino per tè con vaschetta raccogliogocce

Höhe	height	Größe	size	Cromargan®	versilbert
cm	in.	cm	in.	stainless 18/10	silverplated
3	1 <sup>1</sup> / <sub>4</sub>	12 x 9,5	4 <sup>3</sup> / <sub>4</sub> x 3 <sup>3</sup> / <sub>4</sub>	<b>06.3327.6040</b>	<b>19.3327.6440</b>



### Zitronenpresse, 6er Set

lemon/orange squeezer, set of 6  
presse-citron, en 6 parties  
exprimidor para limones, 6 piezas  
spremilimone, a 6 vaschette

Cromargan® mattiert / stainless 18/10, satin finished

**06.8221.6030**



**Kaffeekanne**

coffee pot  
cafetière  
cafetera  
caffettiera

doppelwandig /  
double wall

Cromargan® / stainless 18/10

Höhe cm	height in.	Inhalt Ltr.	cap. oz.	
16	6 1/4	0,3	10,14	55.0046.6040
20	7 3/4	0,6	20,28	55.0047.6040
25,5	10	1,2	40,56	55.0048.6040



**Kaffeebereiter**

coffee press  
cafetière à piston  
cafetera de émbolo  
caffettiera con filtro

doppelwandig /  
double wall

Cromargan® / stainless 18/10

Höhe cm	height in.	Inhalt Ltr.	cap. oz.	
20	7 3/4	0,6	20,28	55.0047.6041
25,5	10	1,2	40,56	55.0048.6041



**Teekanne**

tea pot  
théière  
tetera  
teiera

doppelwandig /  
double wall

Cromargan® / stainless 18/10

Höhe cm	height in.	Inhalt Ltr.	cap. oz.	
17	6 3/4	0,6	20,28	55.0050.6040
19,5	7 3/4	1,2	40,56	55.0051.6040



**Teesieb**

tea strainer  
passoire à thé  
interior colador tè  
colino per tè

Cromargan® / stainless 18/10

Höhe cm	height in.	Ø cm	Ø in.	
9	3 1/2	8,5*	3 1/4*	55.0053.6040
9	3 1/2	10,7**	4 1/4**	55.0054.6040

\* für Teekanne doppelwandig 0,6 l / for tea pot double wall 0,6 l

\*\* für Teekanne doppelwandig 1,2 l / for tea pot double wall 1,2 l





### Teesieb-Behälter

tea strainer holder  
soucoupe pour passoire à thé  
recipiente colador té  
contenitore per colino tè

passend für die Siebe der doppelwandigen Teekannen /  
fitting for the strainers of the double wall tea pots

Porzellan, weiß / porcelain, white

Höhe	height	Ø	Ø
cm	in.	cm	in.
8,2	3 <sup>1</sup> / <sub>4</sub>	8	3 <sup>1</sup> / <sub>4</sub>

55.0094.9990



### Milchkanne

milk jug  
pot à lait  
lechera  
lattiera

doppelwandig /  
double wall

Cromargan® / stainless 18/10

Höhe	height	Inhalt	cap.
cm	in.	Ltr.	oz.
12,7	5	0,3	10,14

55.0055.6040



### Kaffeekanne

#### URBAN

coffee pot  
cafetière  
cafetera  
caffettiera

Höhe	height	Inhalt	cap.	Cromargan®	versilbert
cm	in.	Ltr.	oz.	stainless 18/10	silverplated
13,5	5 <sup>1</sup> / <sub>4</sub>	0,3	10,14	06.3342.6041	19.3342.6441
15,5	6	0,5	16,9	06.3344.6041	19.3344.6441
20	7 <sup>3</sup> / <sub>4</sub>	1	33,8	06.3346.6041	19.3346.6441
23,5	9 <sup>1</sup> / <sub>4</sub>	1,5	50,7	06.3347.6041	19.3347.6441



### Teekanne

#### URBAN

tea pot  
théière  
tetera  
teiera

Höhe	height	Inhalt	cap.	Cromargan®	versilbert
cm	in.	Ltr.	oz.	stainless 18/10	silverplated
12	4 <sup>3</sup> / <sub>4</sub>	0,3	10,14	06.3350.6041	19.3350.6441
14	5 <sup>1</sup> / <sub>2</sub>	0,5	16,9	06.3351.6041	19.3351.6441



**Milchkanne**

**URBAN**

milk jug  
pot à lait  
lechera  
lattiera

Höhe cm	height in.	Inhalt Ltr.	cap. oz.	Cromargan® stainless 18/10	versilbert silverplated
9,6	3 <sup>3</sup> / <sub>4</sub>	0,2	6,76	<b>06.3360.6041</b>	<b>19.3360.6441</b>
11,5	4 <sup>1</sup> / <sub>2</sub>	0,3	10,14	<b>06.3361.6041</b>	<b>19.3361.6441</b>



**Zuckerdose**

**URBAN**

sugar basin  
sucrier  
azucarero  
zuccheriera

Höhe cm	height in.	Inhalt Ltr.	cap. oz.	Cromargan® stainless 18/10	versilbert silverplated
7,4	3	0,25	8,45	<b>06.3370.6041</b>	<b>19.3370.6441</b>



**Kaffeekanne**

**CLASSIC**

coffee pot  
cafetière  
cafetera  
caffettiera

Höhe cm	height in.	Inhalt Ltr.	cap. oz.	Cromargan® stainless 18/10	versilbert silverplated
13,5	5 <sup>1</sup> / <sub>4</sub>	0,3	11	<b>06.3501.6040</b>	<b>19.3501.6440</b>
17	6 <sup>3</sup> / <sub>4</sub>	0,6	21	<b>06.3502.6040</b>	<b>19.3502.6440</b>
22	8 <sup>3</sup> / <sub>4</sub>	1,5	53	<b>06.3504.6040</b>	<b>19.3504.6440</b>
25,5	10	2	70	<b>06.3509.6040</b>	



**Teekanne**

**CLASSIC**

tea pot  
théière  
tetera  
teiera

Höhe cm	height in.	Inhalt Ltr.	cap. oz.	Cromargan® stainless 18/10	versilbert silverplated
11	4 <sup>1</sup> / <sub>4</sub>	0,3	11	<b>06.3506.6040</b>	<b>19.3506.6440</b>
14,5	5 <sup>3</sup> / <sub>4</sub>	0,55	19	<b>06.3507.6040</b>	<b>19.3507.6440</b>
17,5	7	1,25	44	<b>06.3508.6040</b>	<b>19.3508.6440</b>

**Milchkanne  
CLASSIC**

milk jug  
pot à lait  
lechera  
lattiera



Höhe cm	height in.	Inhalt Ltr.	cap. oz.	Cromargan® stainless 18/10	versilbert silverplated
8,5	3 1/2	0,15	5	<b>06.3512.6040</b>	<b>19.3512.6440</b>
11	4 1/4	0,3	11	<b>06.3513.6040</b>	<b>19.3513.6440</b>
13,5	5 1/2	0,6	21	<b>06.3514.6040</b>	<b>19.3514.6440</b>

**Zuckerdose  
CLASSIC**

sugar basin  
sucrier  
azucarero  
zuccheriera



Höhe cm	height in.	Inhalt Ltr.	cap. oz.	Cromargan® stainless 18/10	versilbert silverplated
7	2 3/4	0,25	8,8	<b>06.3519.6040</b>	<b>19.3519.6440</b>

**Zuckerdose, mit Deckel  
CLASSIC**

sugar basin, with cover  
sucrier, avec couvercle  
azucarero, con tapa  
zuccheriera, con coperchio



Höhe cm	height in.	Inhalt Ltr.	cap. oz.	Cromargan® stainless 18/10	versilbert silverplated
9,5	3 3/4	0,15	5,3	<b>06.3520.6040</b>	<b>19.3520.6440</b>
12	4 3/4	0,25	8,8	<b>06.3521.6040</b>	<b>19.3521.6440</b>



**Kaffeekanne**

**PURE**

coffee pot  
cafétière  
cafetera  
caffettiera

stapelbar /  
stackable

Cromargan®, teilmattiert /  
stainless 18/10, partly satin finished

Höhe cm	height in.	Inhalt Ltr.	cap. oz.	
11,5	4½	0,3	11	<b>06.3801.6040</b>
14	5½	0,6	21	<b>06.3808.6040</b>
20	8	1,9	66,5	<b>06.3809.6040</b>



**Teekanne**

**PURE**

tea pot  
théière  
tetera  
teiera

stapelbar /  
stackable

Cromargan®, teilmattiert /  
stainless 18/10, partly satin finished

Höhe cm	height in.	Inhalt Ltr.	cap. oz.	
9,5	3¾	0,3	11	<b>06.3802.6040</b>



**Sahnegießer**

**PURE**

creamer  
crémier  
cremera  
cremiera

Cromargan®, teilmattiert /  
stainless 18/10, partly satin finished

Höhe cm	height in.	Inhalt Ltr.	cap. oz.	
5	2	0,03	1,1	<b>06.3807.6040</b>





### Zuckerdosierer

sugar dispenser  
saupoudreuse à sucre  
dosificador azúcar  
versazucchero

Cromargan®, Glas / stainless 18/10, glass

Höhe	height	Inhalt	cap.
cm	in.	Ltr.	oz.
15,5	6	0,24	8,4

**06.3661.6040**

Ersatzteil / spare part:  
Ersatzglas / spare glass

60.8294.9990



### Honig-/Sahnespender

honey/cream dispenser  
distributeur à miel / crème  
dispensador miel / nata  
versamiele / versalette

Cromargan®, Glas / stainless 18/10, glass

Höhe	height	Inhalt	cap.
cm	in.	Ltr.	oz.
15,5	6	0,24	8,4

**06.3664.6040**

Ersatzteil / spare part:  
Ersatzglas / spare glass

60.8294.9990



### Zuckergestell, 4tlg. CLASSIC

sugar server, set of 4  
service à sucre, en 4 parties  
servicio de azúcar, 4 piezas  
zuccheriera, a 4 vaschette

Höhe	height
cm	in.
21	8 1/4

Cromargan®	versilbert
stainless 18/10	silverplated
<b>06.3186.6040</b>	<b>19.3186.6440</b>

Ersatzteil / spare part:  
Porzellaneinsatz / porcelain insert

60.3099.9990



### Serviertablett für Zucker

serving tray for sugar  
plateau de service pour sucre  
bandeja con azucareros  
vassoio per zucchero

Tablett, oval / serving tray, oval

Größe	size
cm	in.
22 x 15,5	8 3/4 x 6

Cromargan®	versilbert
stainless 18/10	silverplated
<b>06.7540.6040</b>	<b>19.7540.6440</b>

Zuckerdose / sugar bowl

Inhalt	cap.	Ø	Ø	Cromargan®
Ltr.	oz.	cm	in.	stainless 18/10
0,1	3,5	6	2 1/4	<b>06.3752.6040</b>

\* Artikel einzeln bestellen / please order articles separately



**Milch-Zucker-Set  
CLASSIC**

sugar and creamer set  
service pots à lait / sucriers  
juego azucarero / cremera  
set lattiera zuccheriera

Cromargan® / stainless 18/10

Höhe	height
cm	in.
18,5	7 1/4

06.3185.6040

Ersatzteil / spare part:

Milchkanne / milk jug

06.3415.6040

Höhe	height	Inhalt	cap.
cm	in.	Ltr.	oz.
8	3 1/4	0,15	5,3

Zuckerdose / sugar bowl

06.3752.6040

Inhalt	cap.	Ø	Ø
Ltr.	oz.	cm	in.
0,1	3,5	6	2 1/4



**Sahne-Zucker-Set  
PURE**

sugar and creamer set  
service pots à lait / sucriers  
juego azucarero / cremera  
set lattiera zuccheriera

bestehend aus: Gestell, Sahnekännchen, Zuckerdose /  
consisting of: stand, cream dispenser, sugar dispenser

Cromargan®, teilmattiert /  
stainless 18/10, partly satin finished

Höhe	height	Inhalt	cap.
cm	in.	Ltr.	oz.
18	7	0,2	7

06.3804.6040

Ersatzteil / spare part:

Gestell / stand

06.3804.6045

Milchkännchen / creamer

06.3806.6040

Zuckerdose / sugar basin

06.3805.6040



**Sahne-Zucker-Set  
PURE**

sugar and creamer set  
service pots à lait / sucriers  
juego azucarero / cremera  
set lattiera zuccheriera

bestehend aus: Gestell, Sahnekännchen, Zuckerstangengefäß /  
consisting of: stand, cream dispenser, sugar pack holder

Cromargan®, teilmattiert /  
stainless 18/10, partly satin finished

Höhe	height	Inhalt	cap.
cm	in.	Ltr.	oz.
18	7	0,2	7

06.3803.6040

Ersatzteil / spare part:

Gestell / stand

06.3804.6045

Milchkännchen / creamer

06.3806.6040

Zuckerstangengefäß / sugar pack holder

06.7120.6040



### Zuckergestell, 4tlg.

#### PURE

sugar set, 4 pcs.  
service à sucriers, 4 parties  
juego azucarero, 4 piezas  
set zuccheriera, a 4vaschette

bestehend aus: Gestell, 4x Zuckerbehälter /  
consisting of: stand, 4 sugar bowls

Cromargan® / stainless 18/10

Höhe	height	Ø	Ø	
cm	in.	cm	in.	
16,1	6 1/2	14	5 1/2	<b>06.2339.6040</b>

Ersatzteil / spare part:

Gestell nieder / stand low 06.2340.6045

Höhe	height	Ø	Ø
cm	in.	cm	in.
16	6 1/4	14	5 1/2

Porzellaneinsatz / porcelain insert 60.3099.9990



### Sahne-Zucker-Set

#### PURE

sugar and milk set  
service pots à lait / sucriers  
juego azucarero / cremera  
set lattiera zuccheriera

bestehend aus Gestell, 2x Zuckerbehälter Glas und Sahnekännchen  
Porzellan /  
consisting of: stand, 2x sugar bowl glass and creamer porcelain

Cromargan®, Glas, Porzellan / stainless 18/10, glass, porcelain

Gestell nieder / stand low

Höhe	height	Ø	Ø	
cm	in.	cm	in.	
16	6 1/4	14	5 1/2	<b>06.2340.6045</b>

Glas S (VPE 6 Stk.) / glass S (unit 6 pcs.)

Höhe	height	Inhalt	cap.	
cm	in.	Ltr.	oz.	
7,4	3	0,1	3,4	<b>60.2506.9990</b>

Ring S / ring S **06.2502.6040**

Deckel mit Ausschnitt / lid with cut-out **55.0031.6040**

Sahnekännchen (VPE 6 Stk.) / creamer (unit 6 pcs.)

Höhe	height	Inhalt	cap.	
cm	in.	Ltr.	oz.	
7	2 3/4	0,1	3,4	<b>55.0033.9990</b>

Griff S / handle S **06.2509.6040**

Espresso-/Mokkalöffel / demi-tasse spoon **54.9901.6040**

**\* Artikel einzeln bestellen / please order articles separately**



**Milch-Zucker-Set, 3tlg.**

**PURE**

sugar and milk set, set of 3  
 service pots à lait / sucriers, en 3 parties  
 juego azucarero / cremera, 3 piezas  
 set lattiera zuccheriera, a 3 vaschette

bestehend aus: Gestell, 2x Zuckerbehälter, 1 Sahnekännchen /  
 consisting of: stand, 2x sugar bowl, 1 milk pot

Cromargan® / stainless 18/10

Höhe	height	Ø	Ø	
cm	in.	cm	in.	
16,1	6 1/2	14	5 1/2	<b>06.2340.6040</b>

Ersatzteil / spare part:

Zuckerdose, mit Deckel / sugar basin, with cover 06.2342.6040

Höhe	height	Inhalt	cap.	Ø	Ø
cm	in.	Ltr.	oz.	cm	in.
5,2	2	0,1	3,5	6	2 1/4

Gestell nieder / stand low 06.2340.6045

Höhe	height	Ø	Ø
cm	in.	cm	in.
16	6 1/4	14	5 1/2

Milchkännchen / creamer 06.3806.6040

Höhe	height	Inhalt	cap.
cm	in.	Ltr.	oz.
8,5	3 1/4	0,2	7



## Milch-Zucker-Set PURE EXCLUSIV

sugar and milk set  
service pots à lait / sucriers  
juego azucarero / cremera  
set lattiera zuccheriera

in 2 Holzvarianten. Mit 3 Einsätzen für wahlweise Gläser S, Tassen S (o. Abb.) oder Sahnekännchen KAFFEEKULTUR und Tassen S von CULTURECUP (o. Abb.). Nicht spülmaschinengeeignet! /  
in 2 wood versions. With 3 inserts alternatively for glasses S, cups S (w/o pic.) or creamer of CoffeeCulture and cups S of CultureCup (w/o pic.). Not dishwasher-safe!

Cromargan®, Holz dunkel gebeizt, Holz lackiert /  
stainless 18/10, wood dark stained, wood lacquered



Menage klein dunkel / stand small dark

Größe	size	
cm	in.	
20,5 x 6,2 x 3,7	8 x 2 1/2 x 1 1/2	55.0039.6040

Menage klein natur / stand small nature

Größe	size	
cm	in.	
20,5 x 6,2 x 3,7	8 x 2 1/2 x 1 1/2	55.0039.6140



Glas S (VPE 6 Stk.) / glass S (unit 6 pcs.)

Höhe	height	Inhalt	cap.	
cm	in.	Ltr.	oz.	
7,4	3	0,1	3,4	60.2506.9990

Sahnekännchen (VPE 6 Stk.) / creamer (unit 6 pcs.)

Höhe	height	Inhalt	cap.	
cm	in.	Ltr.	oz.	
7	2 3/4	0,1	3,4	55.0033.9990

Deckel mit Ausschnitt / lid with cut-out 55.0031.6040

Espresso-/Mokkalöffel / demi-tasse spoon 54.9901.6040

**\* Artikel einzeln bestellen / please order articles separately**



**Milch-Zucker-Set, 4tlg.**

**PURE EXCLUSIV**

sugar and milk set, set of 4  
 service pots à lait / sucriers, en 4 parties  
 juego azucarero / cremera, 4 piezas  
 set lattiera zuccheriera, a 4 vaschette

in 2 Holzvarianten. Mit 4 Einsätzen für Gläser S oder Tassen S (o.Abb.) von KAFFEEKULTUR, Sahnekännchen und Zuckerstangengefäß von PURE oder Tassen S von CULTURECUP (o.Abb.). Nicht spülmaschinengeeignet! / in 2 wood versions. With 4 inserts for glasses S or cups S (w/o pic.) of CoffeeCulture or creamer and sugar pack holder of PURE or cups S of CultureCup (w/o pic.). Not dishwasher-safe!

Cromargan®, Holz dunkel gebeizt, Holz lackiert / stainless 18/10, wood dark stained, wood lacquered

Menage groß dunkel / stand large dark

Größe	size	
cm	in.	
14,5 x 14,5 x 25,4	5 <sup>3</sup> / <sub>4</sub> x 5 <sup>3</sup> / <sub>4</sub> x 10	<b>55.0034.6040</b>

Menage groß natur / stand large nature

Größe	size	
cm	in.	
14,5 x 14,5 x 25,4	5 <sup>3</sup> / <sub>4</sub> x 5 <sup>3</sup> / <sub>4</sub> x 10	<b>55.0034.6140</b>

Glas S (VPE 6 Stk.) / glass S (unit 6 pcs.)

Höhe	height	Inhalt	cap.
cm	in.	Ltr.	oz.
7,4	3	0,1	3,4
			<b>60.2506.9990</b>

Milchkännchen / creamer

Höhe	height	Inhalt	cap.
cm	in.	Ltr.	oz.
8,5	3 <sup>1</sup> / <sub>4</sub>	0,2	7
			<b>06.3806.6040</b>

Zuckerstangengefäß / sugar pack holder

Höhe	height	Ø	Ø
cm	in.	cm	in.
8,5	3 <sup>1</sup> / <sub>4</sub>	6	2 <sup>1</sup> / <sub>4</sub>
			<b>06.7120.6040</b>

Deckel mit Ausschnitt / lid with cut-out

**55.0031.6040**

Espresso-/Mokkalöffel / demi-tasse spoon

**54.9901.6040**

\* Artikel einzeln bestellen / please order articles separately



### Milch-Zucker-Set, 4tlg.

#### PURE EXCLUSIV

sugar and milk set, set of 4  
 service pots à lait / sucriers, en 4 parties  
 juego azucarero / cremera, 4 piezas  
 set lattiera zuccheriera, a 4 vaschette

in 2 Holzvarianten. Mit 4 Einsätzen für Gläser S oder Tassen S (o.Abb.) von KAFFEEKULTUR, Sahnekännchen und Zuckerdose von PURE oder Tassen S von CULTURECUP (o.Abb.). Nicht spülmaschinengeeignet! / in 2 wood versions. With 4 inserts for glasses S or cups S (w/o pic.) of CoffeeCulture or creamer and sugar basin of PURE or cups S of CultureCup (w/o pic.). Not dishwasher-safe!

Cromargan®, Holz dunkel gebeizt, Holz lackiert / stainless 18/10, wood dark stained, wood lacquered

#### Menage groß dunkel / stand large dark

Größe	size	
cm	in.	
14,5 x 14,5 x 25,4	5 <sup>3</sup> / <sub>4</sub> x 5 <sup>3</sup> / <sub>4</sub> x 10	<b>55.0034.6040</b>

#### Menage groß natur / stand large nature

Größe	size	
cm	in.	
14,5 x 14,5 x 25,4	5 <sup>3</sup> / <sub>4</sub> x 5 <sup>3</sup> / <sub>4</sub> x 10	<b>55.0034.6140</b>

#### Glas S (VPE 6 Stk.) / glass S (unit 6 pcs.)

Höhe	height	Inhalt	cap.	
cm	in.	Ltr.	oz.	
7,4	3	0,1	3,4	<b>60.2506.9990</b>

#### Zuckerdose, mit Deckel / sugar basin, with cover

Höhe	height	Inhalt	cap.	Ø	Ø	
cm	in.	Ltr.	oz.	cm	in.	
5,2	2	0,1	3,5	6	2 <sup>1</sup> / <sub>4</sub>	<b>06.2342.6040</b>

#### Milchkännchen / creamer

Höhe	height	Inhalt	cap.	
cm	in.	Ltr.	oz.	
8,5	3 <sup>1</sup> / <sub>4</sub>	0,2	7	<b>06.3806.6040</b>

#### Deckel mit Ausschnitt / lid with cut-out

**55.0031.6040**

#### Espresso-/Mokkalöffel / demi-tasse spoon

**54.9901.6040**

\* Artikel einzeln bestellen / please order articles separately



**Zuckerdose**

**PURE**

sugar basin  
sucrier  
azucarero  
zuccheriera

Cromargan®, teilmattiert /  
stainless 18/10, partly satin finished

Höhe	height	Inhalt	cap.
cm	in.	Ltr.	oz.
8,5	3 1/4	0,2	7

06.3805.6040



**Zuckerdose, mit Deckel**

**PURE**

sugar basin, with cover  
sucrier, avec couvercle  
azucarero, con tapa  
zuccheriera, con coperchio

Cromargan®, teilmattiert /  
stainless 18/10, partly satin finished

Höhe	height	Inhalt	cap.	Ø	Ø
cm	in.	Ltr.	oz.	cm	in.
5,2	2	0,1	3,5	6	2 1/4

06.2342.6040



**Zuckerstangengefäß**

**PURE**

sugar pack holder  
pots à sucriers  
azucarero para azúcar en cañas  
set zuccheriera

stapelbar /  
stackable

Cromargan®, teilmattiert /  
stainless 18/10, partly satin finished

Höhe	height	Ø	Ø
cm	in.	cm	in.
8,5	3 1/4	6	2 1/4

06.7120.6040



**Milchkännchen**

**PURE**

creamer  
pots à lait  
cremera  
lattiera

Cromargan®, teilmattiert /  
stainless 18/10, partly satin finished

Höhe	height	Inhalt	cap.
cm	in.	Ltr.	oz.
8,5	3 1/4	0,2	7

06.3806.6040



**Zahnstocher- und Süßstoffbehälter  
PURE**

toothpick- and sweetener box-holder  
porte-cure-dents et récipient pour sucrées  
palillero y dispensador de edulcorante  
porta stuzzicadenti e contenitore per dolcificante

zum Einhängen in alle WMF PURE-Gestelle mit Bügelgriff.  
Laser-Gravur der Tischnummer nach Wunsch - Preis auf Anfrage /  
fitting in all racks of WMF PURE sets. Engraving of the table No. on  
request - please ask for respective costs

Cromargan® / stainless 18/10

Höhe	height
cm	in.
4	1½

06.1905.6044



**Kaffeetablett  
PURE**

serving tray  
plateau de service  
bandeja  
vassoio

stapelbar, oval /  
stackable, oval

Cromargan® / stainless 18/10

Größe	size
cm	in.
27 x 17	10½ x 6¾

06.7550.6040



**Porzellanschale, 3-geteilt  
PURE**

porcelain bowl 3-section  
coupe en porcelaine 3 parties  
cuenco de porcelana 3 divisiones  
vassoietto tripartito portazzucchero

mit 2 Unterteilungen für Tee, Zucker oder Antipasti /  
with 2 partitions for tea, sugar or Antipasti

Porzellan weiß / porcelain white

Größe	size
cm	in.
21 x 8,7 x 3,25	8¼ x 3½ x 1¼

60.3538.9990

Zubehör / accessory:

Tablett, oval / serving tray, oval

Größe	size
cm	in.
24,5 x 12	9½ x 4¾

06.7551.6040





**Tablett, oval**

serving tray, oval  
 plateau de service, ovale  
 bandeja, oval  
 vassoio, ovale

Größe cm	size in.
22 x 15,5	8 <sup>3</sup> / <sub>4</sub> x 6
27 x 20	10 <sup>1</sup> / <sub>2</sub> x 8
29 x 22,5	11 <sup>1</sup> / <sub>2</sub> x 8 <sup>3</sup> / <sub>4</sub>

Cromargan® stainless 18/10	versilbert silverplated
<b>06.7540.6040</b>	<b>19.7540.6440</b>
<b>06.7542.6040</b>	<b>19.7542.6440</b>
<b>06.7543.6040</b>	<b>19.7543.6440</b>

**Rotweinwiege**

red wine cradle  
porte-bouteille  
portabotellas  
versavino

für Flasche 0,75 Ltr. /  
for bottle 26,3 oz.

verchromt / chromeplated

06.8045.5080

**Weinkorb**

wine-basket  
panier à vin  
cesta vino  
cestino portavino

versilbert / silverplated

Höhe	height	Größe	size	
cm	in.	cm	in.	
17,5	7	23,5 x 10	9 1/4 x 4	19.2379.6440

**Punchbowl  
CLASSIC**

punch bowl  
bol à punch  
ponchera  
bowl per punch

Cromargan® / stainless 18/10

Höhe	height	Inhalt	cap.	Ø	Ø	
cm	in.	Ltr.	oz.	cm	in.	
29	11 1/2	10	350	38,5	15 1/4	06.0446.6040

versilbert / silverplated

Höhe	height	Inhalt	cap.	Ø	Ø	
cm	in.	Ltr.	oz.	cm	in.	
29	11 1/2	10	350	38,5	15 1/4	19.0446.6440

**Punchbowl  
PURE**

punch bowl  
bol à punch  
ponchera  
bowl per punch

Cromargan® / stainless 18/10

Höhe	height	Ø	Ø	
cm	in.	cm	in.	
27	10 3/4	38	15	06.0471.6040

**Punchbowl****NEUTRAL**

punch bowl  
bol à punch  
ponchera  
bowl per punch

Cromargan® / stainless 18/10

Höhe	height	Inhalt	cap.	Ø	Ø	
cm	in.	Ltr.	oz.	cm	in.	
29	11½	10	350	38,5	15¼	<b>06.0449.6040</b>

**Wein-/Sektküher****CLASSIC**

wine / champagne cooler  
seau à vin / champagne  
cubo vino / champán  
rinfrescavino / spumante

oval, für 2 Flaschen /  
oval, for 2 bottles



Höhe	height		Cromargan®	versilbert
cm	in.		stainless 18/10	silverplated
20,6	8		<b>06.8191.6040</b>	<b>19.8191.6440</b>

**Wein-/Sektküher****CLASSIC**

wine / champagne cooler  
seau à vin / champagne  
cubo vino / champán  
rinfrescavino / spumante

passend in Weinkühlerständer mit Durchmesser mind. 15 cm /  
fitting in stand for wine/champagne cooler with dia. 15 cm minimum

rund /  
round



Höhe	height		Cromargan®	versilbert
cm	in.		stainless 18/10	silverplated
20,8	8¼		<b>06.8190.6040</b>	<b>19.8190.6440</b>

**Wein-/Sektküher****CLASSIC**

wine / champagne cooler  
seau à vin / champagne  
cubo vino / champán  
rinfrescavino / spumante

rund, für 2 Flaschen. Passend in Weinkühlerständer mit Durchm. mind.  
20 cm /  
round, for 2 bottles. Fitting in stand for wine/champagne with dia.  
20 cm minimum



Cromargan® / stainless 18/10

Höhe	height		
cm	in.		
23,5	9¼		<b>06.8051.6040</b>



### Wein-/Sektküher

#### PURE

wine / champagne cooler  
 seu à vin / champagne  
 cubo vino / champán  
 rinfrescavino / spumante

rund. Passend in Weinkühlerständer mit Durchm. mind. 16 cm /  
 round. Fitting in stand for wine/champagne with dia. 16 cm minimum

Cromargan® / stainless 18/10

Höhe	height	Ø	Ø
cm	in.	cm	in.
22	8 <sup>3</sup> / <sub>4</sub>	19	7 <sup>1</sup> / <sub>2</sub>

06.0469.6040



### Weinkühler

#### URBAN

wine / champagne cooler  
 seu à vin / champagne  
 cubo vino / champán  
 rinfrescavino / spumante

doppelwandig. Passend in Weinkühlerständer mit Durchm. mind.  
 16 cm. /  
 double wall. Fitting in stand for wine/champagne with dia. 16 cm  
 minimum.

Cromargan® / stainless 18/10

Höhe	height	Ø	Ø
cm	in.	cm	in.
24	9 <sup>1</sup> / <sub>2</sub>	16	6 <sup>1</sup> / <sub>4</sub>

55.0064.6040



### Wein-/Sektküher

#### NEUTRAL

wine / champagne cooler  
 seu à vin / champagne  
 cubo vino / champán  
 rinfrescavino / spumante

rund. Passend in Weinkühlerständer mit Durchm. mind. 16 cm /  
 round. Fitting in stand for wine/champagne with dia. 16 cm minimum

Cromargan® / stainless 18/10

Höhe	height
cm	in.
20,8	8 <sup>1</sup> / <sub>4</sub>

06.8019.6040



### Weinkühler

wine cooler  
 seu à vin  
 cubo vino  
 rinfrescavino

doppelwandig. Passend in Weinkühlerständer mit Durchm. mind. 12,5  
 cm /  
 double wall. Fitting in stand for wine/champagne with dia. 12,5 cm  
 minimum

Cromargan® mattiert / stainless 18/10, satin finished

Höhe	height	Ø	Ø
cm	in.	cm	in.
19,5	7 <sup>3</sup> / <sub>4</sub>	12	4 <sup>3</sup> / <sub>4</sub>

06.8239.6040

**Weinkühlerständer****NEUTRAL**

stand for wine/champagne cooler  
support pour seau à champagne  
portacubos champán  
colonna per secchio spumante

rund /  
round

Höhe cm	height in.	Ø Schale cm	dish Ø in.	Cromargan® stainless 18/10	versilbert silverplated
60	23 <sup>1</sup> / <sub>2</sub>	16	6 <sup>1</sup> / <sub>4</sub>	<b>06.8337.6040</b>	<b>19.8337.6440</b>

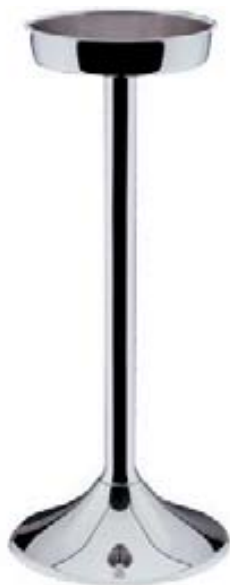
**Weinkühlerständer****NEUTRAL**

stand for wine/champagne cooler  
support pour seau à champagne  
portacubos champán  
colonna per secchio spumante

rund /  
round

Cromargan® / stainless 18/10

Höhe cm	height in.	Ø Schale cm	dish Ø in.	
60	23 <sup>1</sup> / <sub>2</sub>	20	8	<b>06.8452.6040</b>

**Weinkühlerständer****PURE**

stand for wine/champagne cooler  
support pour seau à champagne  
portacubos champán  
colonna per secchio spumante

rund /  
round

Cromargan® / stainless 18/10

Höhe cm	height in.	Ø cm	Ø in.	Ø Schale cm	dish Ø in.	
68,8	27	25	9 <sup>3</sup> / <sub>4</sub>	16	6 <sup>1</sup> / <sub>4</sub>	<b>06.0468.6040</b>



**Flaschenteller  
CLASSIC**

coaster for bottles  
dessous de bouteille  
portabotella  
sottobottiglia

Ø Schale cm	dish Ø in.
10,5	4 <sup>1</sup> / <sub>4</sub>

Cromargan® stainless 18/10	versilbert silverplated
<b>06.2177.6040</b>	<b>19.2177.6440</b>

### Getränkekühler

#### DIVA

beverage cooler  
seau à boisson  
cubo bebida  
rinfresca bevanda



doppelwandig und stapelbar. Kann verwendet werden mit Kühlelement 55.0125.6040, für 3 Wasser-, Saft-, Milchkaraffen 06.1770.6040, 3 Getränkeflaschen (Bsp. Wasser, Wein, etc.) mit max. 10 cm Flaschendurchmesser, 6 Getränkeflaschen (Bsp. Wasser, Saft, Bier etc.) mit max. 7 cm Flaschendurchmesser /

double wall and stackable. Can be used with cooling element 55.0125.6040, for 3 water/juice/milk decanter 06.1770.6040, 3 beverage bottles (e.g. water, wine, etc.) with max. 4 in. bottle diameter, 6 beverage bottles (e.g. water, juice, beer, etc.) with max. 2 3/4 in. bottle diameter

Cromargan® / stainless 18/10

Größe	size	
cm	in.	
27,5 x 26,2 x 17	10 <sup>3</sup> / <sub>4</sub> x 10 <sup>1</sup> / <sub>4</sub> x 6 <sup>3</sup> / <sub>4</sub>	

55.0124.6040



### Kühlelement

#### DIVA

cooling element  
élément réfrigérante  
elemento refrigerador  
elemento per il ghiaccio



mit Kühlgelfüllung zum Einfrieren. Stapelbar. Kann verwendet werden mit Getränkekühler 55.0124.6040 oder separat, für 3 Wasser-, Saft-, Milchkaraffen 06.1770.6040, 3 Getränkeflaschen (Bsp. Wasser, Wein, etc.) mit max. 10 cm Flaschendurchmesser, 6 Getränkeflaschen (Bsp. Wasser, Saft, Bier etc.) mit max. 7 cm Flaschendurchmesser / with cooling core for freezing. Stackable. Can be used with beverage cooler 55.0124.6040 or separately, for 3 water decanter 06.1770.6040, 3 beverage bottles (e.g. water, wine, etc.) with max. 4 in. bottle diameter, 6 beverage bottles (e.g. water, juice, beer, etc.) with max. 2 3/4 in. bottle diameter

Kunststoff / plastic

Größe	size	
cm	in.	
25,3 x 24 x 13,3	10 x 9 <sup>1</sup> / <sub>2</sub> x 5 <sup>3</sup> / <sub>4</sub>	

55.0125.9990





### Eiswasserkrug URBAN

water pitcher  
carafe à l'eau  
jarra agua  
brocca per acqua

mit Eislippe /  
with ice-trap

Cromargan® / stainless 18/10

Höhe cm	height in.	Inhalt Ltr.	cap. oz.
18,5	7 <sup>1</sup> / <sub>4</sub>	1,5	50,7

06.3371.6041



### Eiswasserkrug SCALA

water pitcher  
carafe à l'eau  
jarra agua  
brocca per acqua

mit Eislippe /  
with ice-trap

Höhe cm	height in.	Inhalt Ltr.	cap. oz.	Cromargan® stainless 18/10	versilbert silverplated
23	9	1,9	67	06.1866.6041	19.1866.6441



### Eiswasserkrug

water pitcher  
carafe à l'eau  
jarra agua  
brocca per acqua

mit Eislippe /  
with ice-trap

Cromargan® / stainless 18/10

Höhe cm	height in.	Inhalt Ltr.	cap. oz.
22	8 <sup>3</sup> / <sub>4</sub>	1,5	52,5

06.1860.6040



### Eiswasserkrug PURE

water pitcher  
carafe à l'eau  
jarra agua  
brocca per acqua

mit Eislippe /  
with ice-trap

Cromargan®, teilmattiert /  
stainless 18/10, partly satin finished

Höhe cm	height in.	Inhalt Ltr.	cap. oz.
20	8	1,9	66,5

06.1865.6040

**Eiswasserkrug**

water pitcher  
pichet à eau froide double paroi  
jarra agua  
brocca termica a doppia parete

doppelwandig, mit Eislippe /  
double wall, with ice-trap

Cromargan® / stainless 18/10

Höhe	height	Inhalt	cap.
cm	in.	Ltr.	oz.
23,5	9 <sup>1</sup> / <sub>4</sub>	1,5	50,7

55.0049.6040

**Eisgefäß  
CLASSIC**

ice bucket  
seau à glace  
cubo hielo  
secchiello da ghiaccio

mit Eiseinsatz /  
with grid



Cromargan® / stainless 18/10

Höhe	height	Inhalt	cap.
cm	in.	Ltr.	oz.
12	4 <sup>3</sup> / <sub>4</sub>	1,5	52,5

06.1761.6040

**Eisgefäß  
URBAN**

ice bucket  
seau à glace  
cubo hielo  
secchiello da ghiaccio

doppelwandig /  
double wall



Cromargan® / stainless 18/10

Höhe	height	Ø	Ø
cm	in.	cm	in.
15	6	14	5 <sup>1</sup> / <sub>2</sub>

55.0065.6040

**Eisgefäß  
NEUTRAL**

ice bucket  
seau à glace  
cubo hielo  
secchiello da ghiaccio

Cromargan® / stainless 18/10

Höhe	height	Inhalt	cap.
cm	in.	Ltr.	oz.
12	4 <sup>3</sup> / <sub>4</sub>	1,5	52,5

06.1760.6040





**Eisgefäß  
PURE**

ice bucket  
seau à glace  
cubo hielo  
secchiello da ghiaccio

Cromargan® teilmattiert / stainless 18/10 partly satin finished

Höhe	height	Inhalt	cap.	
cm	in.	Ltr.	oz.	
15	6	1,5	52,5	<b>06.1767.6040</b>



**Eisgefäß**

ice bucket  
seau à glace  
cubo hielo  
secchiello da ghiaccio

doppelwandig /  
double wall

Cromargan® / stainless 18/10

Höhe	height	Inhalt	cap.	Ø	Ø	
cm	in.	Ltr.	oz.	cm	in.	
15	6	0,7	23,66	12,5	5	<b>55.0035.6040</b>



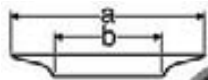

**Platzteller  
RESIDENCE**

plate tray  
assiette de présentation  
bajoplato  
piatto segnaposto

Cromargan® / stainless 18/10

Ø a	Ø a	Ø b	Ø b
cm	in.	cm	in.
33	13	19	7½

06.7473.6090\*

\* Rand geprägt / striked rim

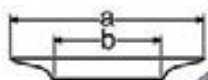

**Platzteller**

plate tray  
assiette de présentation  
bajoplato  
piatto segnaposto

Ø a	Ø a	Ø b	Ø b	Cromargan®	versilbert
cm	in.	cm	in.	stainless 18/10	silverplated
32	12½	19	7½	06.7416.9990*	19.7416.6440*
33	13	21	8¼	06.7417.6040**	

\* für Teller Ø 28 cm / for plates Ø 11 in.

\*\* für Teller Ø 30 cm / for plates Ø 11¾ in.



**Tellercloche  
CLASSIC**

plate cover  
cloche pour assiette  
campana con pomolo  
copripiatto con pomolo

auflegend /  
salient

Ø Fond	Ø inside
cm	in.
25	9¾

Cromargan®	versilbert
stainless 18/10	silverplated
06.7148.6040	19.7148.6440



**Tellercloche  
NEUTRAL**

plate cover  
cloche pour assiette  
campana con pomolo  
copripiatto con pomolo

auflegend /  
salient

Cromargan® / stainless 18/10

Ø Fond	Ø inside
cm	in.
25	9¾

06.7113.6040

### Teller cloche

plate cover  
 cloche pour assiette  
 campana  
 copripiatto con pomolo

stapelbar /  
 stackable

Cromargan® / stainless 18/10

Ø Fond cm	Ø inside in.
26	10 <sup>1</sup> / <sub>4</sub>
27,1	10 <sup>3</sup> / <sub>4</sub>
28	11

06.7089.6040

06.7086.6040

06.7087.6040





**Sauciere  
NEUTRAL**

gravy boat  
saucière  
salsera  
salsiere

auf Fuß /  
footed

Cromargan® / stainless 18/10

Inhalt	cap.
Ltr.	oz.
0,15	5,3
0,3	10,5
0,5	17,5

**06.6244.6040**  
**06.6245.6040**  
**06.6246.6040**



**Sauciere  
PURE**

gravy boat  
saucière  
salsera  
salsiere

auf Fuß, stapelbar /  
footed, stackable

Cromargan® teilmattiert / stainless 18/10 partly satin finished

Inhalt	cap.
Ltr.	oz.
0,2	7
0,5	17,5

**06.0473.6040**  
**06.0474.6040**



**Légumier  
CLASSIC**

vegetable dish and cover  
légumier et couvercle  
legumbrera con tapa  
legumiera con coperchio

Cromargan® / stainless 18/10

Inhalt	cap.	Ø	Ø	Unterteil	Deckel
Ltr.	oz.	cm	in.	base	cover
0,35	12,3	14	5½	<b>06.2701.6041</b>	
		14	5½		<b>06.2701.6042</b>

versilbert / silverplated

Inhalt	cap.	Ø	Ø	Unterteil	Deckel
Ltr.	oz.	cm	in.	base	cover
0,35	12,3	14	5½	<b>19.2701.6441</b>	
		14	5½		<b>19.2701.6442</b>



**Légumier  
NEUTRAL**

vegetable dish and cover  
légumier et couvercle  
legumbreira con tapa  
legumiera con coperchio

Cromargan® / stainless 18/10

Inhalt	cap.	Ø	Ø	Unterteil	Deckel
Ltr.	oz.	cm	in.	base	cover
0,35	12,3	14	5 1/2	<b>06.2786.6041</b>	<b>06.2786.6042</b>
0,6	21	16	6 1/4	<b>06.2787.6041</b>	<b>06.2787.6042</b>
		16	6 1/4		



**Universalschale  
PURE**

universal dish  
coupe universelle  
recipiente universal  
ciotola universale

stapelbar /  
stackable



Cromargan® teilmattiert / stainless 18/10 partly satin finished

Höhe	height	Ø Schale	dish Ø	
cm	in.	cm	in.	
5,5	2 1/4	12	4 3/4	<b>06.1799.6040</b>

**Universalschale**

finger bowl  
coupe universelle  
recipiente universal  
ciotola universale

Cromargan® / stainless 18/10

Inhalt	cap.	Ø Schale	dish Ø	
Ltr.	oz.	cm	in.	
0,2	7	12	4 3/4	<b>06.1849.6040</b>



**Butterkühler  
CLASSIC**

butter cooler  
refraîchisseur à beurre  
enfriador para mantequilla  
rinfresca-burro

Höhe	height	Ø	Ø	Cromargan®	versilbert
cm	in.	cm	in.	stainless 18/10	silverplated
8	3 1/4	5,5	2 1/4	<b>06.1090.6040</b>	<b>19.1090.6440</b>

Ersatzteil / spare part:  
Porzellanunterteil / porcelain base

60.3038.0690



**Butterkühler  
CLASSIC**

butter cooler  
refraîchisseur à beurre  
enfriador para mantequilla  
rinfresca-burro

mit Unterteller /  
with underliner

Cromargan® / stainless 18/10

Höhe	height	Ø	Ø
cm	in.	cm	in.
6	2 <sup>1</sup> / <sub>4</sub>	15,5	6

**06.1087.6040**

Ersatzteil / spare part:

Unterteil / base 06.1085.6041

Einsatzsieb / sieve 06.1085.6044

Cloche / cover 06.1087.6042

Unterteller / underliner 06.1087.6043



**Butterkühler  
NEUTRAL**

butter cooler  
refraîchisseur à beurre  
enfriador para mantequilla  
rinfresca-burro

mit Unterteller /  
with underliner

Cromargan® / stainless 18/10

Höhe	height	Ø	Ø
cm	in.	cm	in.
6,5	2 <sup>1</sup> / <sub>2</sub>	14,5	5 <sup>3</sup> / <sub>4</sub>

**06.1089.6040**

Ersatzteil / spare part:

Einsatzsieb / sieve 06.1089.6044

Unterteller / underliner 06.1089.6043



**Butterkühler  
CLASSIC**

butter cooler  
refraîchisseur à beurre  
enfriador para mantequilla  
rinfresca-burro

	Ø	Ø	Cromargan®	versilbert
	cm	in.	stainless 18/10	silverplated
Unterteil / base	12	4 <sup>3</sup> / <sub>4</sub>	<b>06.3847.6041</b>	<b>19.3847.6441</b>
Einsatz / sieve			<b>06.1082.6044</b>	<b>19.1082.6444</b>



### Butterkühler

butter cooler  
refraîchisseur à beurre  
enfriador para mantequilla  
rinfresca-burro

Cromargan® / stainless 18/10



	Inhalt Ltr.	cap. oz.	Ø Schale cm	dish Ø in.
Universalschale / finger bowl	0,2	7	12	4 <sup>3</sup> / <sub>4</sub>
Einsatz / sieve				

**06.1849.6040**

**06.1082.6044**

### Dessertgestell PURE EXCLUSIV

dessert stand  
présentoir à gâteau  
soporte plato postre  
porta piattini per dessert

in 2 Holzvarianten. Mit 3 Einsätzen für wahlweise Gläser S, Tassen S oder Sahnekännchen (o. Abb.) von KaffeeKultur und Tassen S von CultureCup (o. Abb.). Nicht spülmaschinengeeignet! (ohne Gläser) /  
in 2 wood versions. With 3 inserts alternatively for glasses S, cups S or creamer (w/o pic.) of CoffeeCulture and cups S CultureCup (w/o pic.).  
Not dishwasher-safe! (w/o glasses)



Cromargan®, Holz dunkel gebeizt, Holz lackiert /  
stainless 18/10, wood dark stained, wood lacquered

Menage klein dunkel / stand small dark

Größe cm	size in.
20,5 x 6,2 x 3,7	8 x 2 <sup>1</sup> / <sub>2</sub> x 1 <sup>1</sup> / <sub>2</sub>

**55.0039.6040**

Menage klein natur / stand small nature

Größe cm	size in.
20,5 x 6,2 x 3,7	8 x 2 <sup>1</sup> / <sub>2</sub> x 1 <sup>1</sup> / <sub>2</sub>

**55.0039.6140**



Glas S (VPE 6 Stk.) / glass S (unit 6 pcs.)

Höhe cm	height in.	Inhalt Ltr.	cap. oz.
7,4	3	0,1	3,4

**60.2506.9990**

\* Artikel einzeln bestellen / please order articles separately

**Dessertgestell  
PURE EXCLUSIV**

dessert stand  
présentoir à gâteau  
soporte plato postre  
porta piattini per dessert

in 2 Holzvarianten. Mit 3 Einsätzen für wahlweise Gläser S, Tassen S (o. Abb.) oder Sahnekännchen von KaffeeKultur und Tassen S von CultureCup (o. Abb.). Nicht spülmaschinengeeignet! /  
in 2 wood versions. With 3 inserts alternatively for glasses S, cups S (w/o pic.) or creamer of CoffeeCulture and cups S of CultureCup (w/o pic.). Not dishwasher-safe!

Cromargan®, Holz dunkel gebeizt, Holz lackiert /  
stainless 18/10, wood dark stained, wood lacquered

Menage klein dunkel / stand small dark

Größe	size	
cm	in.	
20,5 x 6,2 x 3,7	8 x 2 <sup>1</sup> / <sub>2</sub> x 1 <sup>1</sup> / <sub>2</sub>	55.0039.6040

Menage klein natur / stand small nature

Größe	size	
cm	in.	
20,5 x 6,2 x 3,7	8 x 2 <sup>1</sup> / <sub>2</sub> x 1 <sup>1</sup> / <sub>2</sub>	55.0039.6140

Sahnekännchen (VPE 6 Stk.) / creamer (unit 6 pcs.)

Höhe	height	Inhalt	cap.	
cm	in.	Ltr.	oz.	
7	2 <sup>3</sup> / <sub>4</sub>	0,1	3,4	55.0033.9990

Deckel mit Ausschnitt / lid with cut-out 55.0031.6040

Espresso-/Mokkalöffel / demi-tasse spoon 54.9901.6040

\* Artikel einzeln bestellen / please order articles separately



**Menage  
PURE EXCLUSIV**

menage  
menagère, à tapenades  
set 3 recipientes  
ménage per tapenade

in 2 Holzvarianten. Für Tapenade, Fleur de Sel oder Saucen und Dips /  
in 2 wood versions. For tapenade, fleur de sel or dips

Cromargan®, Holz dunkel gebeizt, Holz lackiert /  
stainless 18/10, wood dark stained, wood lacquered

Menage klein dunkel / stand small dark

Größe	size	
cm	in.	
20,5 x 6,2 x 3,7	8 x 2 <sup>1</sup> / <sub>2</sub> x 1 <sup>1</sup> / <sub>2</sub>	55.0039.6040

Menage klein natur / stand small nature

Größe	size	
cm	in.	
20,5 x 6,2 x 3,7	8 x 2 <sup>1</sup> / <sub>2</sub> x 1 <sup>1</sup> / <sub>2</sub>	55.0039.6140

Porzellanschälchen (VPE 6 Stk.) / porcelain bowl (unit 6 pcs.)

Höhe	height	Inhalt	cap.	Ø	Ø	
cm	in.	Ltr.	oz.	cm	in.	
4	1 <sup>1</sup> / <sub>2</sub>	0,04	1,4	5	2	55.0093.9990

Gewürzlöffel / spicy spoon

Länge	length	
cm	in.	
7	2 <sup>3</sup> / <sub>4</sub>	54.9184.6040

\* Artikel einzeln bestellen / please order articles separately



### Dessertgestell

dessert stand  
présentoir à gâteau  
soporte plato postre  
porta piattini per dessert

ohne Gläser /  
w/o glasses

Cromargan® / stainless 18/10

Größe	size
cm	in.
40,6 x 7 x 4,9	16 x 2 <sup>3</sup> / <sub>4</sub> x 2

**06.8230.6040**

Zubehör / accessory:

Glas S (VPE 6 Stk.) / glass S (unit 6 pcs.)

60.2506.9990



### Dessertgestell

dessert stand  
présentoir à gâteau  
soporte platos postre  
porta piattini per dessert

passend für Teller bis Ø 16 cm (ohne Teller) /  
fitting for plates Ø 6<sup>1</sup>/<sub>4</sub> in. (without plates)

Cromargan® / stainless 18/10

Höhe	height	Ø	Ø	Ø Ring	Ø ring
cm	in.	cm	in.	cm	in.
25,5	10	18,5	7 <sup>1</sup> / <sub>4</sub>	10,5	4 <sup>1</sup> / <sub>4</sub>

**06.4397.6040**



### Serviergestell

serving stand  
présentoir à assiette  
soporte platos  
portapiatti

passend für Teller Ø 26 cm (ohne Teller) /  
fitting for plates Ø 10<sup>1</sup>/<sub>4</sub> in. (without plates)

Cromargan® / stainless 18/10

Höhe	height	Ø	Ø	Ø Ring	Ø ring
cm	in.	cm	in.	cm	in.
40	15 <sup>3</sup> / <sub>4</sub>	28,5	11 <sup>1</sup> / <sub>4</sub>	18,6	7 <sup>1</sup> / <sub>4</sub>

**06.4395.6040**



### Kaviarkühler CLASSIC

caviar cooler  
refraîchisseur à caviar  
enfriador caviar  
rinfresca-caviale



	Ø	Ø	Cromargan®	versilbert
	cm	in.	stainless 18/10	silverplated
Unterteil / base	12	4 <sup>3</sup> / <sub>4</sub>	<b>06.3847.6041</b>	<b>19.3847.6441</b>
Einsatz / insert			<b>06.3851.6044</b>	<b>19.3851.6444</b>
Glaseinsatz / glass insert				<b>19.9999.8617</b>



### Chillcup CLASSIC

chillcup  
chillcup  
copa cóctel mariscos  
chillcup

mit Ring und Metalleinsatz /  
with ring and metal insert

Inhalt	cap.	Ø	Ø
Ltr.	oz.	cm	in.
0,12	4,2	12	4 <sup>3</sup> / <sub>4</sub>

Unterteil / base  
Ring / ring

Cromargan® versilbert  
stainless 18/10 silverplated  
**06.3847.6041 19.3847.6441**  
**06.3853.6045 19.3853.6445**



### Chillcup CLASSIC

chillcup  
chillcup  
copa cóctel mariscos  
chillcup

mit Ring und Glaseinsatz /  
with ring and glass insert

Inhalt	cap.	Ø	Ø
Ltr.	oz.	cm	in.
0,12	4,2	12	4 <sup>3</sup> / <sub>4</sub>

Unterteil / base  
Ring / ring  
Glasschale / glass dish

Cromargan® versilbert  
stainless 18/10 silverplated  
**06.3847.6041 19.3847.6441**  
**06.3853.6045 19.3853.6445**  
**19.9999.8616**



### Eisschale

ice cream bowl  
coupe à glace  
copa helado  
coppa gelato

Cromargan® / stainless 18/10

Höhe	height	Inhalt	cap.	Ø	Ø
cm	in.	Ltr.	oz.	cm	in.
4,5	1 <sup>3</sup> / <sub>4</sub>	0,1	3,38	10,5	4 <sup>1</sup> / <sub>4</sub>

**55.0093.6040**



**Mokkaétagère  
CLASSIC**

pastry stand  
porte petits fours  
portapastas  
alzata portadolci

2 Ebenen /  
2 levels

versilbert / silverplated

Höhe cm	height in.	Ø Schale cm	Ø bowl in.	
21,5	8½	10,7 / 15,5	4¼ / 6	19.6907.6440



**Mokkaétagère  
URBAN**

pastry stand  
porte petits fours  
portapastas  
alzata porta dolci

Cromargan® / stainless 18/10

Höhe cm	height in.	Ø cm	Ø in.	
13,3	5¼	20	7¾	55.0066.6040



**Mokkaétagère, 3-teilig  
PURE**

pastry stand, 3 parts  
porte petits fours, en 3 parties  
portapastas, de 3 pisos  
alzata portadolci, 3 piani

Cromargan® / stainless 18/10

Höhe cm	height in.	Ø Schale cm	Ø bowl in.	
22,5	8¾	9 / 14 / 20	3½ / 5½ / 8	06.6903.6040



**Mokkaétagère, 2 tlg.  
PURE**

pastry stand, 2 parts  
porte petits fours, en 2 parties  
portapastas, de 2 pisos  
alzata portadolci, 2 piani

Cromargan® / stainless 18/10

Höhe cm	height in.	Ø cm	Ø in.	Ø Schale cm	Ø bowl in.	
14,5	5¾	20	7¾	14 / 20	5½ / 8	06.8254.6040





### Petits Fours-Ständer CLASSIC

petits-fours-stand  
porte petits fours  
portapastas  
alzata porta dolci

Höhe	height	Ø	Ø	Cromargan®	versilbert
cm	in.	cm	in.	stainless 18/10	silverplated
13	5	15,5	6	<b>06.4379.6040</b>	<b>19.4379.6440</b>



### Petits Fours-Ständer URBAN

petits-fours-stand  
porte petits fours  
portapastas  
alzata porta dolci

Cromargan® / stainless 18/10

Höhe	height	Ø	Ø	
cm	in.	cm	in.	
8,7	3 1/2	15	6	<b>55.0067.6040</b>



### Petits Fours-Ständer PURE EXCLUSIV

petits-fours-stand  
porte petits fours  
portapastas  
alzata porta dolci

in 2 Holzvarianten. **Metall-Aufsatz Petit-Fours und Tischnummernständer können flexibel getauscht werden.** Höhe Holzfuß 10 cm. Holzfuß nicht spülmaschinenfest! /  
in 2 wood versions. **Metal support for petits-fours or table number stand can be switched flexibly.** Height of wooden foot 10 cm / 4 in..  
Wooden foot not dishwasher-safe!

Cromargan®, Holz dunkel gebeizt, Holz lackiert /  
stainless 18/10, wood dark stained, wood lacquered

Höhe	height	Ø	Ø	
cm	in.	cm	in.	
14	5 1/2	15	6	
				Holzfuß dunkel / stand dark <b>55.0121.6040</b>
				Holzfuß natur / stand nature <b>55.0121.6140</b>
				Petits Fours-Aufsatz / petits-fours-support <b>55.0121.6042</b>
				Tischnummernständer-Aufsatz / table number stand support <b>55.0121.6043</b>

\* Artikel einzeln bestellen / please order articles separately



### Petits Fours-Ständer

#### PURE

petits-fours-stand  
 porte petits fours  
 portapastas  
 alzata porta dolci



Cromargan® teilmattiert / stainless 18/10 partly satin finished

Höhe	height	Ø	Ø
cm	in.	cm	in.
10,4	4	15	6

06.0475.6040

### Marmeladegestell

jam stand  
 support pour confiture  
 soporte para mermelada  
 supporto per confettura



mit 5 Ablageflächen mit max. Durchm. 4,9 cm, Vase mittig /  
 with 5 levels with dia. max. 2 in., flower vase in the middle

Cromargan® / stainless 18/10

Höhe	height
cm	in.
20	7 <sup>3</sup> / <sub>4</sub>

06.8231.6040

### Porzellanschale, 3-geteilt

#### PURE

porcelain bowl 3-section  
 coupe en porcelaine 3 parties  
 cuenco de porcelana 3 divisiones  
 vassoietto tripartito portazzucchero



mit 2 Unterteilungen für Tee, Zucker oder Antipasti /  
 with 2 partitions for tea, sugar or Antipasti

Porzellan weiß / porcelain white

Größe	size
cm	in.
21 x 8,7 x 3,25	8 <sup>1</sup> / <sub>4</sub> x 3 <sup>1</sup> / <sub>2</sub> x 1 <sup>1</sup> / <sub>4</sub>

60.3538.9990

Zubehör / accessory:

Tablett, oval / serving tray, oval

Größe	size
cm	in.
24,5 x 12	9 <sup>1</sup> / <sub>2</sub> x 4 <sup>3</sup> / <sub>4</sub>

06.7551.6040



**Toastständer****PURE**

toast rack  
support pour pain grillé  
portatostadas  
porta-toast

passend in Tablett 06.7551.6040 /  
fitting in serving tray 06.7551.6040

Cromargan® / stainless 18/10

Größe	size
cm	in.
20 x 8 x 6,5	8 x 3 <sup>1</sup> / <sub>4</sub> x 2 <sup>1</sup> / <sub>2</sub>

**06.4280.6040****Tablett, oval****PURE**

serving tray, oval  
plateau de service, ovale  
bandeja, oval  
vassoio, ovale

passend für Toastständer 06.4280.6040 und Porzellanschale 3geteilt  
60.3538.9990 /

suitable for toast rack 06.4280.6040 and for porcelain bowl 3pcs.  
60.3538.9990

stapelbar /  
stackable

Cromargan® / stainless 18/10

Größe	size
cm	in.
24,5 x 12	9 <sup>1</sup> / <sub>2</sub> x 4 <sup>3</sup> / <sub>4</sub>

**06.7551.6040****Relish-Pickles-Gestell****NEUTRAL**

relish or condiment server  
service à relish  
porta aperitivos  
portasalatini / olive

Cromargan® / stainless 18/10

Höhe	height	Ø Schale	dish Ø
cm	in.	cm	in.
13	5	8	3 <sup>1</sup> / <sub>4</sub>

**06.2829.6040**

### Relish-Pickles-Gestell CLASSIC

relish or condiment server  
service à relish  
porta aperitivos  
portasalatini / olive



Höhe cm	height in.	Ø Schale cm	dish Ø in.	Cromargan® stainless 18/10	versilbert silverplated
19,5	7 <sup>3</sup> / <sub>4</sub>	8	3 <sup>1</sup> / <sub>4</sub>	<b>06.2846.6040</b>	<b>19.2846.6440</b>



### Bargestell, 3teilig

bar-relish dish, 3 pieces  
service à relish, 3 parties  
soporte de bar, 3 recipientes  
set per bar, 3 pezzi

drehbar /  
turnable

Cromargan® / stainless 18/10

Höhe cm	height in.	Ø Schale cm	dish Ø in.	
19	7 <sup>1</sup> / <sub>2</sub>	8	3 <sup>1</sup> / <sub>4</sub>	<b>06.2831.6040</b>

Ersatzteil / spare part:  
Glasschale / glass dish

19.9999.8616

**Eierbecher-Set**

egg cup set  
set de coquetier  
set de huevera  
set portauovo

stapelbar /  
stackable

Cromargan® / stainless 18/10

Ø	Ø	Stück
cm	in.	pcs.
8,5	3 <sup>1</sup> / <sub>3</sub>	6

06.1640.6040

**Eierlöffel**

egg spoon  
cuiller à oeuf  
cuchara huevos  
cucchiaio per uovo



Cromargan® / stainless 18/10

Länge	length
cm	in.
13	5

12.9008.6040\*

\* VPE 12 Stk. / unit 12 pcs.

**Tischrestebehälter****PURE**

silent waiter  
boîte de table  
recipiente desperdicios  
porta rifiuti per tavolo



Deckel zum Abnehmen, auch als Kühler für kleine Flaschen einsetzbar,  
stapelbar /  
detachable lid, can also be used to cool small bottles, stackable

Cromargan® teil mattiert / stainless 18/10 partly satin finished

Höhe	height	Ø	Ø
cm	in.	cm	in.
15	6	14	5 <sup>1</sup> / <sub>2</sub>

06.1758.6040

**Krümelsammler**

table crumbler  
ramasse-brosse  
recogemigas  
raccoglibriciole



Cromargan® / stainless 18/10

Länge	length
cm	in.
15	6

06.7707.6000



### Zahnstocherbehälter

#### CLASSIC

toothpick-holder  
 porte-cure-dents  
 palillero  
 porta stuzzicadenti



Höhe	height
cm	in.
6	2 <sup>1</sup> / <sub>4</sub>

rostfrei	versilbert
stainless steel	silverplated
<b>06.8406.1680</b>	<b>19.8406.1440</b>

### Zahnstocherbehälter

#### PURE

toothpick-holder  
 porte-cure-dents  
 palillero  
 porta stuzzicadenti



Cromargan®, teilmattiert /  
 stainless 18/10, partly satin finished

Höhe	height
cm	in.
7	2 <sup>3</sup> / <sub>4</sub>

**06.8413.6040**



### Zahnstocher- und Süßstoffbehälter

#### PURE

toothpick- and sweetener box-holder  
 porte-cure-dents et récipient pour sucrées  
 palillero y dispensador de edulcorante  
 porta stuzzicadenti e contenitore per dolcificante

zum Einhängen in alle WMF PURE-Gestelle mit Bügelgriff.  
 Laser-Gravur der Tischnummer nach Wunsch - Preis auf Anfrage /  
 fitting in all racks of WMF PURE sets. Engraving of the table No. on  
 request - please ask for respective costs

Cromargan® / stainless 18/10

Höhe	height
cm	in.
4	1 <sup>1</sup> / <sub>2</sub>

**06.1905.6044**



### Ascher

#### PURE

ash tray  
 cendrier  
 cenicero  
 posacenere

stapelbar /  
 stackable



Cromargan®, teilmattiert /  
 stainless 18/10, partly satin finished

Höhe	height	Ø	Ø
cm	in.	cm	in.
5	2	14	5 <sup>1</sup> / <sub>2</sub>

**06.5552.6040**



**Zigarrenabschneider**

cigar cutter  
coupe-cigares  
cortapuros  
spuntasigari

Edelstahl 18/10 / stainless 18/10

Länge	length
cm	in.
10	4

55.0094.6040

**Früchtekorb**

fruit basket  
panier à fruits  
frutero  
fruttiera

passend in Etagère 06.3010.6040, 06.3011.6040, 06.2441.6040  
combiNation buffet nur in Verbindung mit Kühlbehälter 06.3014.6045  
(bitte separat bestellen) /  
fitting together with cooler 06.3014.6045 (please order separately) in  
etagere 06.3010.6040, 06.3011.6040, 06.2441.6040 combiNation buffet

Cromargan® / stainless 18/10

Höhe	height	Ø	Ø
cm	in.	cm	in.
22,5	8 <sup>3</sup> / <sub>4</sub>	26	10 <sup>1</sup> / <sub>4</sub>

**06.6521.6040****Brotkorb, rund  
OLE PALSBY**

bread-basket, round  
panier à pain, rond  
cesta del pan, redonda  
cestino per il pane, rotondo



Cromargan® / stainless 18/10

Ø	Ø
cm	in.
18	7 <sup>1</sup> / <sub>2</sub>
21	8 <sup>1</sup> / <sub>4</sub>
26	10 <sup>1</sup> / <sub>4</sub>

**06.6575.6040****06.6513.6040****06.6514.6040****Brotkorb  
PURE**

bowl for bread  
panier à pain  
panera  
portapane

stapelbar /  
stackable



Cromargan® teilmattiert / stainless 18/10 partly satin finished

Größe	size
cm	in.
25 x 14 x 5	9 <sup>3</sup> / <sub>4</sub> x 5 <sup>1</sup> / <sub>2</sub> x 2

**06.6535.6040****Brotkorb**

bread-basket  
panier à pain  
cesta del pan  
cestino per il pane

nicht mit Wasser oder Chemikalien reinigen. Reinigung nur im  
Silbertauchbad oder mit speziellen Pflegemitteln für Silberartikel /  
do not clean with water or chemicals. Cleaning only in silver-dip-bath  
or with special polish for silver articles

versilbert / silverplated

Größe	size
cm	in.
22,3 x 16,3 x 6	8 <sup>3</sup> / <sub>4</sub> x 6 <sup>1</sup> / <sub>2</sub> x 2 <sup>1</sup> / <sub>4</sub>
27 x 19 x 6,5	10 <sup>3</sup> / <sub>4</sub> x 7 <sup>1</sup> / <sub>2</sub> x 2 <sup>1</sup> / <sub>2</sub>

**19.6319.7030****19.6329.6440**

**Brottschale**

bowl for bread  
panier à pain  
panera  
portapane

Größe	size
cm	in.
28 x 17	11 x 6 <sup>3</sup> / <sub>4</sub>

Cromargan®	versilbert
stainless 18/10	silverplated
<b>06.6380.6040</b>	<b>19.6380.6440</b>



**Brottschale**

bowl for bread  
panier à pain  
panera  
portapane

oval, Durchbruchdekor /  
oval, stencil pattern

Cromargan® / stainless 18/10

Größe	size
cm	in.
20 x 15	8 x 6

**06.6571.6040**



**Universalschale**

**PURE**

universal dish  
coupe universelle  
recipiente universal  
ciotola universale

stapelbar /  
stackable

Cromargan® teilmattiert / stainless 18/10 partly satin finished

Höhe	height	Ø Schale	dish Ø
cm	in.	cm	in.
5,5	2 <sup>1</sup> / <sub>4</sub>	12	4 <sup>3</sup> / <sub>4</sub>

**06.1799.6040**



**Universalschale**

finger bowl  
coupe universelle  
recipiente universal  
ciotola universale

Cromargan® / stainless 18/10

Inhalt	cap.	Ø Schale	dish Ø
Ltr.	oz.	cm	in.
0,2	7	12	4 <sup>3</sup> / <sub>4</sub>

**06.1849.6040**





**Obstschale**  
**BISTRO**

fruit stand  
coupe à fruits  
frutero  
alzata per frutta

Cromargan®, Glas / stainless 18/10, glass

Höhe	height	Ø Schale	Ø bowl
cm	in.	cm	in.
16	6 <sup>1</sup> / <sub>4</sub>	38	15

**06.6895.6040**

Ersatzteil / spare part:

Glasschale mittel / glass plate medium

19.9999.8644



**Obstschale**

fruit bowl  
coupe à fruits  
frutero  
alzata per frutta

Cromargan® / stainless 18/10

Größe	size
cm	in.
22,5 x 22,5 x 7,2	8 <sup>3</sup> / <sub>4</sub> x 8 <sup>3</sup> / <sub>4</sub> x 2 <sup>3</sup> / <sub>4</sub>

**06.8236.6040**





**Leuchter, 3-flammig  
URBAN**

candelabra, 3-branched  
chandelier, 3 branches  
candelabro, 3 brazos  
candeliere, 3 fiamme

Cromargan® / stainless 18/10

Länge cm	length in.	Höhe cm	height in.
23,8	9 <sup>1</sup> / <sub>4</sub>	22,5	8 <sup>3</sup> / <sub>4</sub>

55.0069.6040



**Leuchter, 3-armig  
PURE**

candelabra, 3-branched  
chandelier, 3 branches  
candelabro, 3 brazos  
candeliere, 3 fiamme

Cromargan®, teilmattiert /  
stainless 18/10, partly satin finished

Höhe cm	height in.
36	14 <sup>1</sup> / <sub>4</sub>

06.4753.6040



**Leuchter, 5-armig  
PURE**

candelabra, 5-branched  
chandelier, 5 branches  
candelabro, 5 brazos  
candeliere, 5 fiamme

Cromargan®, teilmattiert /  
stainless 18/10, partly satin finished

Höhe cm	height in.
36	14 <sup>1</sup> / <sub>4</sub>

06.4754.6040

**Leuchter  
CLASSIC**

candle stick  
chandelier  
candellero  
candeliere



versilbert / silverplated

Höhe	height
cm	in.
12	4 <sup>3</sup> / <sub>4</sub>

19.4990.6440

**Leuchter  
URBAN**

candle stick  
chandelier  
candellero  
candeliere



Cromargan® / stainless 18/10

Länge	length	Höhe	height
cm	in.	cm	in.
6,4	2 <sup>1</sup> / <sub>2</sub>	21	8 <sup>1</sup> / <sub>4</sub>

55.0060.6040

**Leuchter  
PURE EXCLUSIV**

candle stick  
chandelier  
candellero  
candeliere



Cromargan®, Holz dunkel gebeizt /  
stainless 18/10, wood dark stained

Höhe	height	Ø	Ø
cm	in.	cm	in.
20,4	8	9	3 <sup>1</sup> / <sub>2</sub>
30,4	12	9	3 <sup>1</sup> / <sub>2</sub>

55.0018.6040

55.0017.6040

**Leuchter  
PURE**

candle stick  
chandelier  
candellero  
candeliere



Cromargan®, teilmattiert /  
stainless 18/10, partly satin finished

Höhe	height
cm	in.
10,5	4 <sup>1</sup> / <sub>4</sub>

06.4751.6040



**Windlicht**

**PURE**

table lamp with glass  
 chandelier avec verrine  
 linterna con cristal  
 lampa da tavola alta con paralume

ohne Kerzen. Für Teelichter /  
 w/o candles. For tealights

Cromargan®, teilmattiert, Glas /  
 stainless 18/10, partly satin finished, glass

Höhe	height
cm	in.
21	8 <sup>1</sup> / <sub>4</sub>

06.8202.6040

Ersatzteil / spare part:  
 Ersatzglas / spare glass

60.3051.9990



**Windlicht, matt**

**PURE**

table lamp with glass, satin  
 chandelier avec verrine, mat  
 linterna con cristal, mate  
 lampa da tavola alta con paralume, di vetro satino

ohne Kerzen. Für Teelichter /  
 w/o candles. For tealights

Cromargan®, teilmattiert, Glas /  
 stainless 18/10, partly satin finished, glass

Höhe	height
cm	in.
21	8 <sup>1</sup> / <sub>4</sub>

06.8208.6040

Ersatzteil / spare part:  
 Ersatzglas / spare glass

60.3052.9990



**Windlicht**

**URBAN**

table lamp  
 chandelier avec verrine  
 linterna con cristal  
 lampa da tavola alta con paralume

ohne Kerzen. Für große Teelichter /  
 w/o candles. For big tealights

Cromargan®, Glas / stainless 18/10, glass

Höhe	height	Ø	Ø
cm	in.	cm	in.
13,5	5 <sup>1</sup> / <sub>4</sub>	8	3 <sup>1</sup> / <sub>4</sub>

55.0070.6040

Ersatzteil / spare part:  
 Ersatzglas zu Windlicht / spare glass for table lamp

55.0070.9990

**Windlicht, groß  
PURE EXCLUSIV**

table lamp, large  
chandelier avec verrine, grand  
linternas con cristal, alta  
lampa da tavola alta con paralume, grande

in 2 Holzvarianten. Ohne Kerzen. Für große Teelichter. Nicht  
spülmaschinengeeignet! /  
in 2 wood versions. W/o candles. For big tealights. Not dishwasher-safe!

Cromargan®, Holz dunkel gebeizt, Holz lackiert, Glas satiniert /  
stainless 18/10, wood dark stained, wood lacquered, glass satin finished



**Windlicht, groß dunkel / table lamp, large dark**

Größe	size	Ø	Ø	
cm	in.	cm	in.	
8 x 8 x 22,3	3 1/4 x 3 1/4 x 8 3/4	13	5	<b>55.0040.6040</b>

**Windlicht, groß natur / table lamp, large nature**

Größe	size	Ø	Ø	
cm	in.	cm	in.	
8 x 8 x 22,3	3 1/4 x 3 1/4 x 8 3/4	13	5	<b>55.0040.6140</b>

Ersatzteil / spare part:

Ersatzglas zu Windlicht groß / spare glass for table lamp large	<b>55.0040.6042</b>
--	---------------------

**Windlicht, klein  
PURE EXCLUSIV**

table lamp, small  
chandelier avec verrine, petit  
linternas con cristal, pequeno  
lampa da tavola alta c. paralum, picc.

in 2 Holzvarianten. Ohne Kerzen. Für Teelichter. Nicht  
spülmaschinengeeignet! /  
in 2 wood versions. W/o candles. For tealights. Not dishwasher-safe!

Cromargan®, Holz dunkel gebeizt, Holz lackiert, Glas satiniert /  
stainless 18/10, wood dark stained, wood lacquered, glass satin finished



**Windlicht, klein dunkel / table lamp, small dark**

Größe	size	Ø	Ø	
cm	in.	cm	in.	
6,3 x 6,3 x 19,3	2 1/2 x 2 1/2 x 7 1/2	9,5	3 3/4	<b>55.0075.6040</b>

**Windlicht, klein natur / table lamp, small nature**

Größe	size	Ø	Ø	
cm	in.	cm	in.	
6,3 x 6,3 x 19,3	2 1/2 x 2 1/2 x 7 1/2	9,5	3 3/4	<b>55.0075.6140</b>

Ersatzteil / spare part:

Ersatzglas zu Windlicht klein / spare glass for table lamp small	<b>55.0075.6042</b>
---	---------------------



**Teelichtleuchter 3fl. klein  
PURE EXCLUSIV**

tealight candle stick, small  
chandelier bougie à chauffe-plat  
candelero lamparilla, peq.  
candeliere lumino, picc.

in 2 Holzvarianten. Mit 3 Einsätzen für Teelichter, Stab- oder  
Stumpenkerzen. Nicht spülmaschinengeeignet! /  
in 2 wood versions. With 3 inserts for tealights and other kinds of  
candles. Not dishwasher-safe!

Cromargan®, Holz dunkel gebeizt, Holz lackiert /  
stainless 18/10, wood dark stained, wood lacquered

Menage klein dunkel / stand small dark

Größe	size	
cm	in.	
20,5 x 6,2 x 3,7	8 x 2 <sup>1</sup> / <sub>2</sub> x 1 <sup>1</sup> / <sub>2</sub>	

**55.0039.6040**

Menage klein natur / stand small nature

Größe	size	
cm	in.	
20,5 x 6,2 x 3,7	8 x 2 <sup>1</sup> / <sub>2</sub> x 1 <sup>1</sup> / <sub>2</sub>	

**55.0039.6140**





**Blumenvase  
CLASSIC**

flower vase  
vase à fleurs  
florero  
vaso da fiori

versilbert / silverplated

Höhe	height
cm	in.
16,5	6 <sup>1</sup> / <sub>2</sub>

19.7962.1440



**Blumenvase  
CLASSIC**

flower vase  
vase à fleurs  
florero  
vaso da fiori

Cromargan® / stainless 18/10

Höhe	height
cm	in.
16	6 <sup>1</sup> / <sub>4</sub>

06.7959.6040



**Blumenvase  
URBAN**

flower vase  
vase à fleurs  
florero  
vaso da fiori

Cromargan® / stainless 18/10

Höhe	height	Ø	Ø
cm	in.	cm	in.
17,5	7	7	2 <sup>3</sup> / <sub>4</sub>

55.0061.6040



**Blumenvase  
PURE**

flower vase  
vase à fleurs  
florero  
vaso da fiori

Cromargan®, teilmattiert /  
stainless 18/10, partly satin finished

Höhe	height
cm	in.
20	8

06.7955.6040



**Blumenvase**

flower vase  
vase à fleurs  
florero  
vaso da fiori

Cromargan® / stainless 18/10

Höhe	height	Ø	Ø
cm	in.	cm	in.
30	11 <sup>3</sup> / <sub>4</sub>	10	4

06.8240.6040



**Blumenvase, klein  
PURE EXCLUSIV**

flower vase, small  
vase à fleurs, petit  
florero, pequeno  
vaso da fiori, piccolo

in 2 Holzvarianten. Für einzelne Blüten. Nicht spülmaschinengeeignet! /  
in 2 wood versions. For single flowers. Not dishwasher-safe!

Cromargan®, Holz dunkel gebeizt, Holz lackiert /  
stainless 18/10, wood dark stained, wood lacquered

Blumenvase, klein dunkel / flower vase, small dark

Größe	size	Ø	Ø
cm	in.	cm	in.
4,5 x 4,5 x 16	1 <sup>3</sup> / <sub>4</sub> x 1 <sup>3</sup> / <sub>4</sub> x 6 <sup>1</sup> / <sub>4</sub>	2,8	1

55.0041.6040

Blumenvase, klein natur / flower vase, small nature

Größe	size	Ø	Ø
cm	in.	cm	in.
4,5 x 4,5 x 16	1 <sup>3</sup> / <sub>4</sub> x 1 <sup>3</sup> / <sub>4</sub> x 6 <sup>1</sup> / <sub>4</sub>	2,8	1

55.0041.6140



**Blumenvase, groß  
PURE EXCLUSIV**

flower vase, large  
vase à fleurs, grande  
florero, grande  
vaso da fiori, grande

in 2 Holzvarianten. Nicht spülmaschinengeeignet! /  
in 2 wood versions. Not dishwasher-safe!

Cromargan®, Holz dunkel gebeizt, Holz lackiert /  
stainless 18/10, wood dark stained, wood lacquered

Blumenvase, groß dunkel / flower vase, large dark

Größe	size	Ø	Ø
cm	in.	cm	in.
8 x 8 x 23,5	3 <sup>1</sup> / <sub>4</sub> x 3 <sup>1</sup> / <sub>4</sub> x 9 <sup>1</sup> / <sub>4</sub>	5,2	2

55.0042.6040

Blumenvase, groß natur / flower vase, large nature

Größe	size	Ø	Ø
cm	in.	cm	in.
8 x 8 x 23,5	3 <sup>1</sup> / <sub>4</sub> x 3 <sup>1</sup> / <sub>4</sub> x 9 <sup>1</sup> / <sub>4</sub>	5,2	2

55.0042.6140



### Tischnummernständer CLASSIC

table number stand  
porte numéro de table  
porta número de mesa  
targhetta ad appoggio per numero tavolo

individuelle Gravur nach Wunsch - Preis auf Anfrage. Tischnummer nicht entfernbar. / individual engraving on request - please ask for respective costs. Table number not removable.

Cromargan® / stainless 18/10

Höhe	height
cm	in.
54	21 <sup>1</sup> / <sub>4</sub>

06.7819.6040



### Tischnummernständer, mit Clip CLASSIC

table number stand, with clip  
porte numéro de table, avec clip  
porta número de mesa, con clip  
segnatavola, con clip

Tischnummer separat zum Einstecken. /  
Table No. to be put in separately.

Cromargan® / stainless 18/10

Höhe	height	Ø	Ø
cm	in.	cm	in.
45,4	17 <sup>3</sup> / <sub>4</sub>	9,7	3 <sup>3</sup> / <sub>4</sub>

06.8250.6040

Zubehör / accessory:

Tischnummer / table number

06.8252.6040

Plastik-Tischnummer / plastic table number

19.9999.2513



### Tischnummernständer PURE

table number stand  
porte numéro de table  
porta número de mesa (sin número)  
segnatavola

Cromargan®, teilmattiert /  
stainless 18/10, partly satin finished

Höhe	height
cm	in.
30,5	12

06.7812.6040

Zubehör / accessory:

Plastik-Tischnummer / plastic table number

19.9999.2513

Tischnummer / table number

06.8252.6040



### Tischnummernständer PURE EXCLUSIV

table number stand  
porte numéro de table  
porta número de mesa  
segnatavola

in 2 Holzvarianten. **Metall-Aufsatz Petit-Fours und Tischnummernständer kann flexibel getauscht werden.** Holzfuß nicht spülmaschinenfest! /

in 2 wood versions. **Metal part for petits-fours or table number stand can be switched flexibly.** Wooden foot not dishwasher-safe!

Cromargan®, Holz dunkel gebeizt, Holz lackiert / stainless 18/10, wood dark stained, wood lacquered

Höhe	height
cm	in.
36,8	14 <sup>1</sup> / <sub>2</sub>

Holzfuß dunkel / stand dark 55.0121.6040

Holzfuß natur / stand nature 55.0121.6140

Petits Fours-Aufsatz / petits-fours-support 55.0121.6042

Tischnummernständer-Aufsatz / table number stand support 55.0121.6043

\* Artikel einzeln bestellen / please order articles separately



### Tischnummernständer

table number stand  
porte numéro de table  
porta número de mesa (sin grabación)  
targhetta ad appoggio per numero tavolo

Cromargan® / stainless 18/10

Höhe	height
cm	in.
28	11

06.7719.1680



### Tischnummern-Aufsteller

table number  
numéro de table  
número de mesa  
numero tavolo

passend zu Tischnummernständer 06.7719.1680, Laser-Gravur nach Wunsch - Preis auf Anfrage / fitting for table number stand 06.7719.1680, engraving on request - please ask for respective costs

Länge	length	Höhe	height	Cromargan®	versilbert
cm	in.	cm	in.	stainless 18/10	silverplated
8,3	3 <sup>1</sup> / <sub>4</sub>	3,6	1 <sup>1</sup> / <sub>2</sub>	06.7701.6040	19.7701.6440



### Kartenhalter PURE EXCLUSIV

card holder  
porte-carte  
portatarjetas  
portacarta

in 2 Holzvarianten. Für Tisch- und Visitenkarten (ohne Karte) /  
in 2 wood versions. For menu and name cards (without card)

Cromargan®, Holz dunkel gebeizt, Holz lackiert /  
stainless 18/10, wood dark stained, wood lacquered

Kartenhalter dunkel / card holder dark

Größe	size	
cm	in.	
4,5 x 4,5 x 6,5	1 <sup>3</sup> / <sub>4</sub> x 1 <sup>3</sup> / <sub>4</sub> x 2 <sup>1</sup> / <sub>2</sub>	55.0080.6040

Kartenhalter natur / card holder nature

Größe	size	
cm	in.	
4,5 x 4,5 x 6,5	1 <sup>3</sup> / <sub>4</sub> x 1 <sup>3</sup> / <sub>4</sub> x 2 <sup>1</sup> / <sub>2</sub>	55.0080.6140



### Speisekartenhalter PURE

menu stand  
porte menu  
porta menus  
portamenu

Cromargan®, teilmattiert /  
stainless 18/10, partly satin finished

Höhe	height	
cm	in.	
7,5	3	06.7813.6040

Zubehör / accessory:

Plastik-Tischnummer / plastic table number	19.9999.2513
Tischnummer / table number	06.8252.6040



### Tischnummer

table number  
numéro de table  
número de mesa  
numero tavolo

passend zu Tischnummernständer 06.8250.6040, 06.7812.6040,  
55.0121.6043 und Speisekartenhalter 06.7813.6040. Individuelle Gravur  
nach Wunsch - Preis auf Anfrage /  
fitting for table number stand 06.8250.6040, 06.7812.6040,  
55.0121.6043 and menu stand 06.7813.6040. Individual engraving on  
request - please ask for respective costs

Cromargan® / stainless 18/10

Ø	Ø	
cm	in.	
13,5	5 <sup>1</sup> / <sub>4</sub>	06.8252.6040



**Plastik-Tischnummer**

plastic table number  
 numéro de table en plastique  
 número de mesa plástico  
 numero tavolo in plastica

passend in Tischnummernständer 06.7812.6040, 06.8250.6040,  
 55.0121.6043 und Speisekartenhalter 06.7813.6040 /  
 fitting in table number stand 06.7812.6040, 06.8250.6040,  
 55.0121.6043 and menu stand 06.7813.6040

Größe	size
cm	in.
10 x 10	4 x 4

19.9999.2513

**Zahnstocher- und Süßstoffbehälter  
PURE**

toothpick- and sweetener box-holder  
 porte-cure-dents et récipient pour sucrètes  
 palillero y dispensador de edulcorante  
 porta stuzzicadenti e contenitore per dolcificante

zum Einhängen in alle WMF PURE-Gestelle mit Bügelgriff.  
 Laser-Gravur der Tischnummer nach Wunsch - Preis auf Anfrage /  
 fitting in all racks of WMF PURE sets. Engraving of the table No. on  
 request - please ask for respective costs

Cromargan® / stainless 18/10

Höhe	height
cm	in.
4	1½

06.1905.6044

**Salzmühle / Pfeffermühle**

salt mill / pepper mill  
moulin à sel / moulin à poivre  
molinillo sal / molinillo pimienta  
macinasale / macinapepe

mit original Keramikmahlwerk /  
with ceramic grinding mechanism

Cromargan®, Acrylglas / stainless 18/10, acrylic glass

Höhe	height	Ø	Ø
cm	in.	cm	in.
12	4 <sup>3</sup> / <sub>4</sub>	5	2
16	6 <sup>1</sup> / <sub>4</sub>	5	2

06.1510.6040

06.3531.6040

**Salzmühle / Pfeffermühle**

salt mill / pepper mill  
moulin à sel / moulin à poivre  
molinillo sal / molinillo pimienta  
macinasale / macinapepe

mit original Keramikmahlwerk. Passend in die großen Ausschnitte der Menagen PURE EXCLUSIV /  
with ceramic grinding mechanism. Fitting in the big cut-outs of the stands high PURE EXCLUSIV

Cromargan®, Holz lackiert / stainless 18/10, wood lacquered

Höhe	height
cm	in.
19	7 <sup>1</sup> / <sub>2</sub>

Salzmühle / Pfeffermühle metall /  
salt mill / pepper mill metal

06.6711.6040

Salzmühle / Pfeffermühle weiß /  
salt mill / pepper mill white

06.6708.4500

Salzmühle / Pfeffermühle schwarz /  
salt mill / pepper mill black

06.6709.4500

Salzmühle / Pfeffermühle rot /  
salt mill / pepper mill red

06.6710.4500

**Salzstreuer / Pfefferstreuer  
URBAN**

salt shaker / pepper shaker  
moulin à sel / moulin à poivre  
molinillo sal / molinillo pimienta  
macinasale / macinapepe

einzelnd stehend oder passend auf Tablett URBAN oder in kleine Ausschnitte von PURE EXCLUSIV Teelichthalter und Menage. /  
stand alone or fitting on tray URBAN or in small cut-outs of PURE EXCLUSIV tealight holder or menage

Cromargan® / stainless 18/10

Höhe	height	Ø	Ø
cm	in.	cm	in.
8,5	3 <sup>1</sup> / <sub>4</sub>	4,5	1 <sup>3</sup> / <sub>4</sub>

Salzstreuer / salt shaker

55.0062.6040

Pfefferstreuer / pepper shaker

55.0063.6040

Ersatzteil / spare part:

Stopfen zu Streuer / stopper for shakers

55.0062.9502



**Salz- und Pfeffergestell  
CLASSIC**

salt-pepper-set  
ménagère 2 pièces  
servicio condimento  
menage

Höhe	height
cm	in.
12,3	5

Cromargan®	versilbert
stainless 18/10	silverplated
<b>06.5171.6040</b>	<b>19.5171.6440</b>

Ersatzteil / spare part:  
Salzstreuer / salt shaker  
Pfefferstreuer / pepper shaker  
Ersatzglas / spare glass

06.6037.6040	19.6037.6440
06.6038.6040	19.6038.6440
	60.6037.9990



**Salz- und Pfeffergestell  
PURE**

salt-pepper-set  
ménagère 2 pièces  
servicio condimento  
menage

Cromargan®, Kappen mattiert, Glas /  
stainless 18/10, tops satin finished, glass

Höhe	height
cm	in.
14,5	5 <sup>3</sup> / <sub>4</sub>

**06.5170.6040**

Ersatzteil / spare part:  
Salzstreuer / salt shaker  
Pfefferstreuer / pepper shaker  
Ersatzglas / spare glass

06.6062.6030
06.6063.6030
60.8253.9960



**Essig-Ölgestell  
CLASSIC**

oil and vinegar set  
huilier-vinaigrier  
vinagreras  
oliera

Höhe	height
cm	in.
23	9

Cromargan®	versilbert
stainless 18/10	silverplated
<b>06.1906.6040</b>	<b>19.1906.6440</b>

Ersatzteil / spare part:

Ersatzflasche / spare bottle				19.9999.8632
Höhe	height	Inhalt	cap.	
cm	in.	Ltr.	oz.	
19	7,5	0,15	5,22	

**Essig-/Öl-Set  
URBAN**

oil and vinegar set  
huilier-vinaigrier  
vinagreras  
oliera

bestehend aus Tablett, Essig- und Ölflasche, Salz- und Pfefferstreuer. /  
consisting of tray, oil and vinegar bottle, salt and pepper shaker

Cromargan®, Glas / stainless 18/10, glass



Tablett / tray	55.0058.6045
Essig-/Ölflasche / oil/vinegar bottle	55.0059.6040
Salzstreuer / salt shaker	55.0062.6040
Pfefferstreuer / pepper shaker	55.0063.6040

Ersatzteil / spare part:

Stopfen zu Streuer / stopper for shakers	55.0062.9502
Ausgießer zu Essig-/Ölflasche / pouirer for oil/vinegar bottle	55.0059.9802
Deckel zu Essig-/Ölflasche / lid for oil/vinegar bottle	55.0059.6803

\* Artikel einzeln bestellen / please order articles separately

**Tablett  
URBAN**

tray  
plateau  
bandeja  
vassoio

Cromargan® / stainless 18/10

Größe	size
cm	in.
23 x 10,7	8 x 4 1/4

55.0058.6045



**Essig-/Ölflasche  
URBAN**

oil/vinegar bottle  
burette à vinaigre/huile  
botella de aceite/vinagre  
caraffa per aceto/olio

Cromargan®, Glas / stainless 18/10, glass

Höhe	height	Inhalt	cap.	Ø	Ø
cm	in.	Ltr.	oz.	cm	in.
15,2	6	0,15	5,07	5,7	2 1/4

55.0059.6040

Ersatzteil / spare part:

Ausgießer zu Essig-/Ölflasche / pouirer for oil/vinegar bottle	55.0059.9802
Deckel zu Essig-/Ölflasche / lid for oil/vinegar bottle	55.0059.6803





**Essig-/Ölgestell, 3 tlg.**

**PURE**

oil and vinegar set, 3 pcs.  
 huilier-vinaigrier, 3 parties  
 vinagreras, 3 piezas  
 oliera, a 3 vaschette

bestehend aus Gestell, Essig- und Ölflasche und Glasbehälter für Senf, Parmesan, Sambal Oelek u.a. /  
 consisting of: stand, oil / vinegar bottle and glass pots for mustard, parmesan, relish, etc.

Cromargan®, Glas / stainless 18/10, glass

Gestell hoch / stand high

Höhe	height	Ø	Ø	
cm	in.	cm	in.	
21	8 1/4	14	5 1/2	<b>06.2341.6045</b>

einzelne Flasche komplett / spare bottle complete

Höhe	height	Inhalt	cap.	
cm	in.	Ltr.	oz.	
16	6 1/2	0,2	6,96	<b>06.6139.6030</b>

Glas S (VPE 6 Stk.) / glass S (unit 6 pcs.)

Höhe	height	Inhalt	cap.	
cm	in.	Ltr.	oz.	
7,4	3	0,1	3,4	<b>60.2506.9990</b>

Ring S / ring S **06.2502.6040**

Deckel mit Ausschnitt / lid with cut-out **55.0031.6040**

Espresso-/Mokkalöffel / demi-tasse spoon **54.9901.6040**

\* Artikel einzeln bestellen / please order articles separately



**Essig-/Ölgestell, 4 tlg.**

**PURE**

oil and vinegar set, 4 pcs.  
 huilier-vinaigrier, 4 parties  
 vinagreras, 4 piezas  
 oliera, a 4 vaschette

bestehend aus: Gestell, Essig- und Ölflasche, Salz- und Pfefferstreuer /  
 consisting of: stand, oil / vinegar bottle, salt / pepper shaker

Cromargan® / stainless 18/10

Höhe	height	Ø	Ø	
cm	in.	cm	in.	
21,1	8 1/2	14	5 1/2	<b>06.2341.6040</b>

Ersatzteil / spare part:

Gestell hoch / stand high **06.2341.6045**

Höhe	height	Ø	Ø
cm	in.	cm	in.
21	8 1/4	14	5 1/2

Salzstreuer / salt shaker **06.6062.6030**

Höhe	height	Ø	Ø
cm	in.	cm	in.
11	4 1/4	4,1	1 1/2

Pfefferstreuer / pepper shaker **06.6063.6030**

Höhe	height	Ø	Ø
cm	in.	cm	in.
11	4 1/4	4,1	1 1/2

einzelne Flasche komplett / spare bottle complete **06.6139.6030**

Höhe	height	Inhalt	cap.
cm	in.	Ltr.	oz.
16	6 1/2	0,2	6,96





## Essig-/Öl-Menage PURE EXCLUSIV

oil and vinegar set  
huilier-vinaigrier  
vinagreras  
oliera

in 2 Holzvarianten. Mit 4 Einsätzen für Salz- und Pfefferstreuer, Essig- und Ölflasche von URBAN. Nicht spülmaschinengeeignet! /  
in 2 wood versions. With 4 inserts for salt shaker, pepper shaker, oil/ vinegar bottle of URBAN. Not dishwasher-safe!

Cromargan®, Holz dunkel gebeizt, Holz lackiert /  
stainless 18/10, wood dark stained, wood lacquered

### Menage groß dunkel / stand large dark

Größe	size	
cm	in.	
14,5 x 14,5 x 25,4	5 <sup>3</sup> / <sub>4</sub> x 5 <sup>3</sup> / <sub>4</sub> x 10	55.0034.6040

### Menage groß natur / stand large nature

Größe	size	
cm	in.	
14,5 x 14,5 x 25,4	5 <sup>3</sup> / <sub>4</sub> x 5 <sup>3</sup> / <sub>4</sub> x 10	55.0034.6140

### Essig-/Ölflasche / oil/vinegar bottle

Höhe	height	Inhalt	cap.	Ø	Ø	
cm	in.	Ltr.	oz.	cm	in.	
15,2	6	0,15	5,07	5,7	2 <sup>1</sup> / <sub>4</sub>	55.0059.6040

### Salzstreuer / salt shaker

Höhe	height	Ø	Ø	
cm	in.	cm	in.	
8,5	3 <sup>1</sup> / <sub>4</sub>	4,5	1 <sup>3</sup> / <sub>4</sub>	55.0062.6040

### Pfefferstreuer / pepper shaker

Höhe	height	Ø	Ø	
cm	in.	cm	in.	
8,5	3 <sup>1</sup> / <sub>4</sub>	4,5	1 <sup>3</sup> / <sub>4</sub>	55.0063.6040

\* Artikel einzeln bestellen / please order articles separately



**Essig-Öl-Menage  
PURE EXCLUSIV**

oil and vinegar set  
huilier-vinaigrier  
vinagreras  
oliera

in 2 Holzvarianten. Gestell mit 4 Einsätzen für Flaschen und Streuer.  
Nicht spülmaschinengeeignet! /  
in 2 wood versions. Stand with 4 inserts for bottles and shaker. Not  
dishwasher-safe!

Cromargan®, Holz dunkel gebeizt, Holz lackiert /  
stainless 18/10, wood dark stained, wood lacquered

Menage groß dunkel / stand large dark

Größe	size	
cm	in.	
14,5 x 14,5 x 25,4	5 <sup>3</sup> / <sub>4</sub> x 5 <sup>3</sup> / <sub>4</sub> x 10	<b>55.0034.6040</b>

Menage groß natur / stand large nature

Größe	size	
cm	in.	
14,5 x 14,5 x 25,4	5 <sup>3</sup> / <sub>4</sub> x 5 <sup>3</sup> / <sub>4</sub> x 10	<b>55.0034.6140</b>

einzelne Flasche komplett / spare bottle complete

Höhe	height	Inhalt	cap.
cm	in.	Ltr.	oz.
16	6 <sup>1</sup> / <sub>2</sub>	0,2	6,96
			<b>06.6139.6030</b>

Salzstreuer / salt shaker

Höhe	height	Ø	Ø
cm	in.	cm	in.
11	4 <sup>1</sup> / <sub>4</sub>	4,1	1 <sup>1</sup> / <sub>2</sub>
			<b>06.6062.6030</b>

Pfefferstreuer / pepper shaker

Höhe	height	Ø	Ø
cm	in.	cm	in.
11	4 <sup>1</sup> / <sub>4</sub>	4,1	1 <sup>1</sup> / <sub>2</sub>
			<b>06.6063.6030</b>

\* Artikel einzeln bestellen / please order articles separately

## Essig-/Öl-Menage PURE EXCLUSIV

oil and vinegar set  
huilier-vinaigrier  
vinagreras  
oliera

in 2 Holzvarianten. Mit 4 Einsätzen für kleine Essig-/Ölflasche PURE, große Essig-Ölflasche PURE, Tassen S mit oder ohne Deckel von KAFFEEKULTUR und Mühle. Nicht spülmaschinengeeignet! /  
in 2 wood versions. With 4 inserts for small oil/vinegar bottle PURE, large oil/vinegar bottle PURE, cup S with or w/o lid of CoffeeCulture and mill. Not dishwasher-safe!

Cromargan®, Holz dunkel gebeizt, Holz lackiert /  
stainless 18/10, wood dark stained, wood lacquered

### Menage groß dunkel / stand large dark

Größe	size	
cm	in.	
14,5 x 14,5 x 25,4	5 <sup>3</sup> / <sub>4</sub> x 5 <sup>3</sup> / <sub>4</sub> x 10	<b>55.0034.6040</b>

### Menage groß natur / stand large nature

Größe	size	
cm	in.	
14,5 x 14,5 x 25,4	5 <sup>3</sup> / <sub>4</sub> x 5 <sup>3</sup> / <sub>4</sub> x 10	<b>55.0034.6140</b>

### Essig-/Ölflasche, klein / oil and vinegar bottle

Höhe	height	Ø	Ø
cm	in.	cm	in.
13	5	4,1	1 <sup>1</sup> / <sub>2</sub>

**55.0098.6040**

### einzelne Flasche komplett / spare bottle complete

Höhe	height	Inhalt	cap.
cm	in.	Ltr.	oz.
16	6 <sup>1</sup> / <sub>2</sub>	0,2	6,96

**06.6139.6030**

### Salzmühle / Pfeffermühle rot / salt mill / pepper mill red

Höhe	height
cm	in.
19	7 <sup>1</sup> / <sub>2</sub>

**06.6710.4500**

### Porzellantasse S (VPE 6 Stk.) / porcelain cup S (unit 6 pcs.)

Höhe	height	Inhalt	cap.
cm	in.	Ltr.	oz.
7,4	3	0,1	3,4

**60.2508.9990**

### Deckel mit Ausschnitt / lid with cut-out

**55.0031.6040**

### Espresso-/Mokkalöffel / demi-tasse spoon

**54.9901.6040**

\* Artikel einzeln bestellen / please order articles separately





**Salz-/Pfeffer-Set  
PURE EXCLUSIV**

salt and pepper set  
ménagère 3 pièces  
servicio condimento  
menage

in 2 Holzvarianten. Bestehend aus: Menage klein, Salz- und Pfefferstreuer, Glas S für Saucen, Butter, Senf... /  
in 2 wood versions. Consisting of: stand small, salt and pepper shaker, glass S for sauce, butter, mustard...

Cromargan®, Holz dunkel gebeizt, Holz lackiert /  
stainless 18/10, wood dark stained, wood lacquered

Menage klein dunkel / stand small dark

Größe	size	
cm	in.	
20,5 x 6,2 x 3,7	8 x 2 1/2 x 1 1/2	<b>55.0039.6040</b>

Menage klein natur / stand small nature

Größe	size	
cm	in.	
20,5 x 6,2 x 3,7	8 x 2 1/2 x 1 1/2	<b>55.0039.6140</b>

Salzstreuer / salt shaker

Höhe	height	Ø	Ø	
cm	in.	cm	in.	
11	4 1/4	4,1	1 1/2	<b>06.6062.6030</b>

Pfefferstreuer / pepper shaker

Höhe	height	Ø	Ø	
cm	in.	cm	in.	
11	4 1/4	4,1	1 1/2	<b>06.6063.6030</b>

Glas S (VPE 6 Stk.) / glass S (unit 6 pcs.)

Höhe	height	Inhalt	cap.	
cm	in.	Ltr.	oz.	
7,4	3	0,1	3,4	<b>60.2506.9990</b>

Deckel mit Ausschnitt / lid with cut-out **55.0031.6040**

Espresso-/Mokkalöffel / demi-tasse spoon **54.9901.6040**

\* Artikel einzeln bestellen / please order articles separately

**Asia-Set  
PURE EXCLUSIV**

Asia set  
kit ASIA  
juego ASIA  
set ASIA

in 2 Holzvarianten. Bestehend aus: Menage klein, Essig- und Sojaflasche klein PURE, Glas S für Saucen, Butter, Senf... /  
in 2 wood versions. Consisting of: menage small, vinegar and soy bottle small PURE, glass S for sauce, butter, mustard...

Cromargan®, Holz dunkel gebeizt, Holz lackiert /  
stainless 18/10, wood dark stained, wood lacquered



Menage klein dunkel / stand small dark

Größe	size	
cm	in.	
20,5 x 6,2 x 3,7	8 x 2 1/2 x 1 1/2	

**55.0039.6040**

Menage klein natur / stand small nature

Größe	size	
cm	in.	
20,5 x 6,2 x 3,7	8 x 2 1/2 x 1 1/2	

**55.0039.6140**

Essig-/Ölflasche, klein / oil and vinegar bottle

Höhe	height	Ø	Ø
cm	in.	cm	in.
13	5	4,1	1 1/2

**55.0098.6040**

Glas S (VPE 6 Stk.) / glass S (unit 6 pcs.)

Höhe	height	Inhalt	cap.
cm	in.	Ltr.	oz.
7,4	3	0,1	3,4

**60.2506.9990**

Deckel mit Ausschnitt / lid with cut-out

**55.0031.6040**

Espresso-/Mokkalöffel / demi-tasse spoon

**54.9901.6040**

**\* Artikel einzeln bestellen / please order articles separately**



**Menage  
PURE EXCLUSIV**

menage  
menagère, à tapenades  
set 3 recipientes  
ménage per tapenade

in 2 Holzvarianten. Für Tapenade, Fleur de Sel oder Saucen und Dips /  
in 2 wood versions. For tapenade, fleur de sel or dips

Cromargan®, Holz dunkel gebeizt, Holz lackiert /  
stainless 18/10, wood dark stained, wood lacquered



Menage klein dunkel / stand small dark

Größe	size	
cm	in.	
20,5 x 6,2 x 3,7	8 x 2 1/2 x 1 1/2	<b>55.0039.6040</b>

Menage klein natur / stand small nature

Größe	size	
cm	in.	
20,5 x 6,2 x 3,7	8 x 2 1/2 x 1 1/2	<b>55.0039.6140</b>

Porzellanschälchen (VPE 6 Stk.) / porcelain bowl (unit 6 pcs.)

Höhe	height	Inhalt	cap.	Ø	Ø	
cm	in.	Ltr.	oz.	cm	in.	
4	1 1/2	0,04	1,4	5	2	<b>55.0093.9990</b>



Gewürzlöffel / spicy spoon

Länge	length	
cm	in.	
7	2 3/4	<b>54.9184.6040</b>

\* Artikel einzeln bestellen / please order articles separately

**Essig-/Ölgestell  
PURE**

oil and vinegar set  
huilier-vinaigrier  
vinagreras  
oliera

Cromargan®, Kappen mattiert, Glas /  
stainless 18/10, tops satin finished, glass

Höhe	height	
cm	in.	
21	8 1/4	<b>06.1905.6040</b>



Ersatzteil / spare part:

einzelne Flasche komplett / spare bottle complete	06.6139.6030
Ersatzflasche / spare bottle	60.8254.9960
Ausgießer / pouring stopper	60.8255.9990

**Zahnstocher- und Süßstoffbehälter  
PURE**

toothpick- and sweetener box-holder  
porte-cure-dents et récipient pour sucrettes  
palillero y dispensador de edulcorante  
porta stuzzicadenti e contenitore per dolcificante

zum Einhängen in alle WMF PURE-Gestelle mit Bügelgriff.

Laser-Gravur der Tischnummer nach Wunsch - Preis auf Anfrage /  
fitting in all racks of WMF PURE sets. Engraving of the table No. on  
request - please ask for respective costs

Cromargan® / stainless 18/10

Höhe	height	
cm	in.	
4	1 1/2	<b>06.1905.6044</b>







**Senftopf  
CLASSIC**

mustard pot  
moutardier  
mostacero  
senapiera

Cromargan® / stainless 18/10

Höhe	height
cm	in.
9	3 1/2

06.6965.6040

Ersatzteil / spare part:  
Ersatzglas / spare glass

19.9999.8639



**Käsedose  
CLASSIC**

parmesan jar  
fromagère  
recipiente  
formaggiera

mit Kristalleinsatz /  
with crystal insert

Cromargan® / stainless 18/10

Ø	Ø
cm	in.
15,5	6

06.2885.6040

Ersatzteil / spare part:  
Ersatzglas / spare glass

19.9999.8637



**Käsedose  
NEUTRAL**

parmesan jar  
fromagère  
recipiente  
formaggiera

mit Kristalleinsatz /  
with crystal insert

Cromargan® / stainless 18/10

Ø	Ø
cm	in.
14,5	5 3/4

06.2868.6040

Ersatzteil / spare part:  
Ersatzglas / spare glass  
Deckel / cover  
Unterteller / underliner

60.8025.9990

06.2868.6042

06.1089.6043



# BUFFET

combiNation buffet

Warmhalten  
keeping warm

Dosieren  
portioning

Präsentieren  
presenting



# combiNation buffet

einfach auf die Schiene  
bringen  
the easiest way to get  
your buffet on track

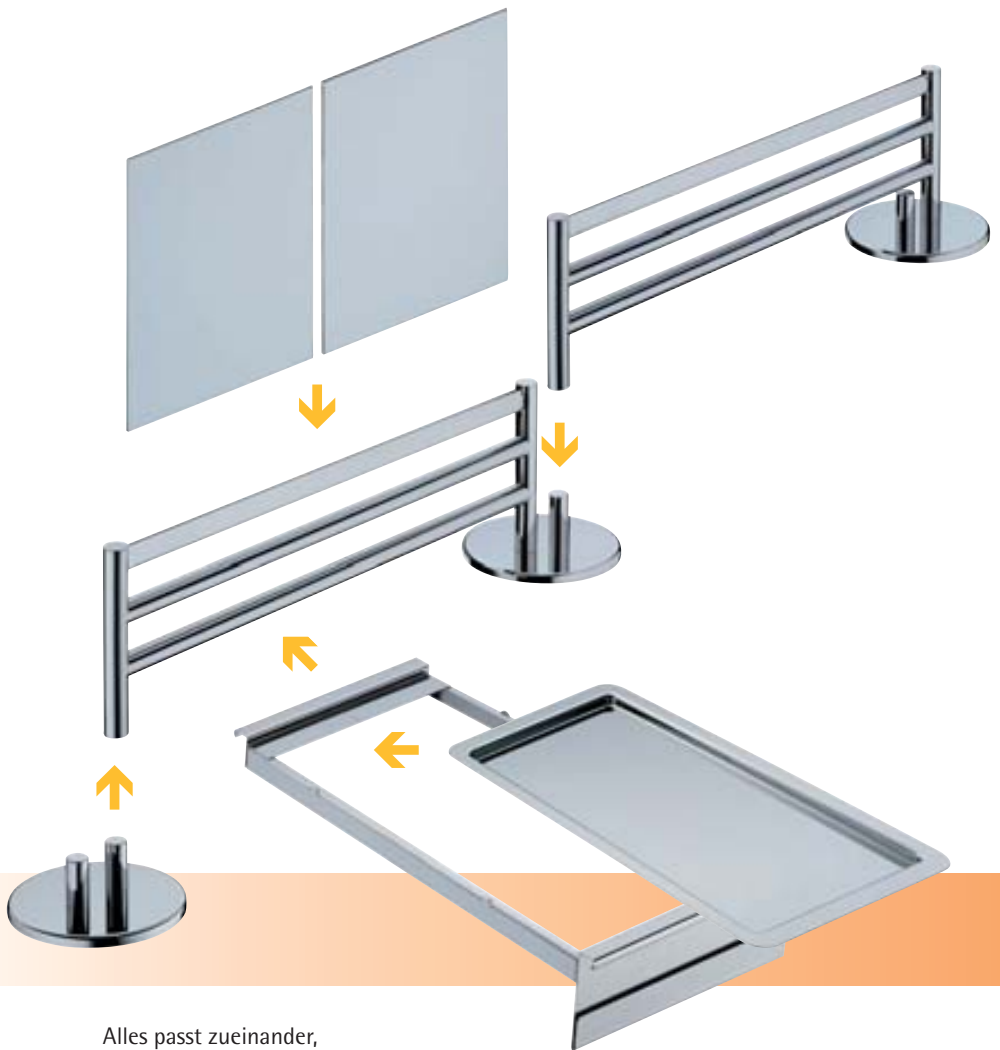

Alles passt zueinander,  
alles passt ineinander  
Everything fits together,  
everything fits in

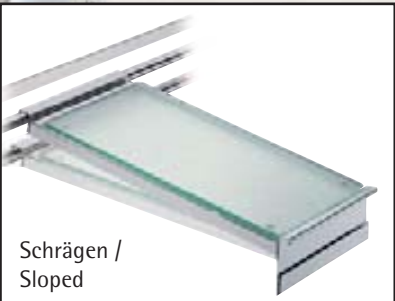

Schrägen /  
Sloped

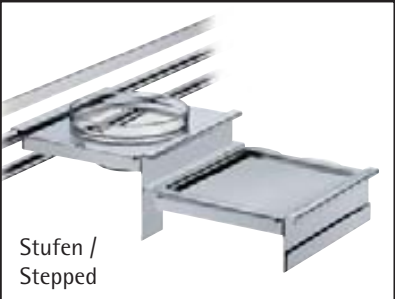
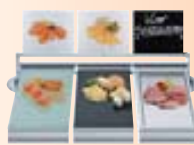

Stufen /  
Stepped

Ihrer Phantasie sind keine Grenzen gesetzt -  
There are no limits to your imagination

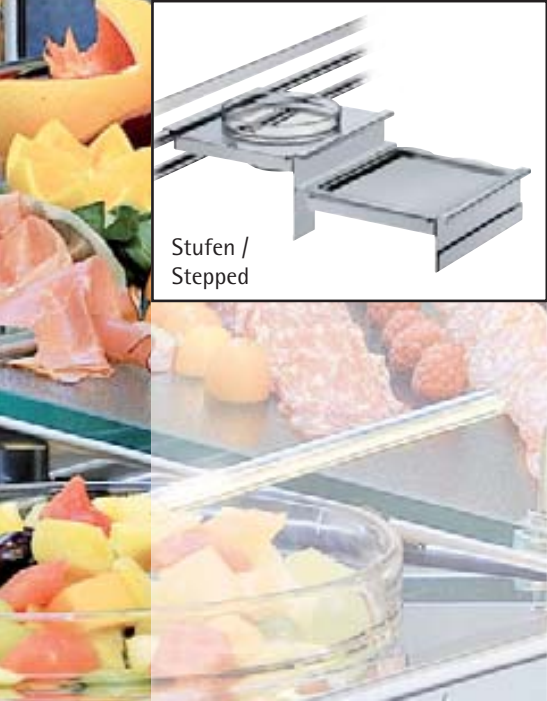
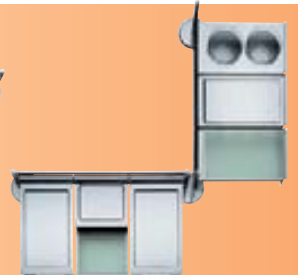





## Produktvorteile

### **einfach und genial**

Das gesamte Buffet wird in Schienen eingehängt. Selbst ungeübte Mitarbeiter erledigen den Umbau intuitiv. Sparen Sie Zeit und schaffen Sie sich Freiraum für die wirklich wichtigen Dinge.

### **einfach variabel und leicht bedienbar**

Alles passt zueinander, hier können Sie kreativ sein. Kein Kaschieren, kein Verstecken – stilsicher bei jedem Aufbau. Der Gesamteindruck ist harmonisch aufeinander abgestimmt. Verschiedene Ebenen und Schrägen, integrierte Beschilderung, unterschiedliche Einsätze – alles lässt sich spielend leicht kombinieren.

### **einfach alles weiterverwenden**

Ihre bereits vorhandenen Gastronormbehälter, Ihre Tablettts, Chafing Dishes und Einsätze – alles kann problemlos eingesetzt werden.

### **einfach heiß und kalt**

Je nach Tageszeit und Speisenauswahl – Sie entscheiden über perfekte Kühlung in der Eiswanne oder gleichmäßiges Warmhalten mit den entsprechenden Heizelementen.

### **einfach platzsparend und ordentlich**

Durch die optimierte Anordnung profitieren Sie von einer enormen Platzersparnis, auch in der größten Hektik – alles bleibt ordentlich, appetitlich und sauber.

### **einfach alles gesagt**

Die ansprechende Präsentation der Speisen anhand der eingesteckten Bilder oder Tafeln sind nicht nur leicht verständlich, sie dienen auch als Appetitanreger und Werbefläche. Auch bei geschlossenen Behältnissen.

## Advantages of the products

### **simply brilliant**

The whole buffet is suspended from rails. Even untrained staff will be able to set it up intuitively. You'll save time and free yourself up to do the things that really matter.

### **simply versatile and easy to use**

Everything fits together, so you can be creative. No need to disguise or conceal anything – making a stylish statement. The overall impression is harmonious and coordinated. Different levels and gradients, integral labelling, various inserts – they can all be combined effortlessly.

### **simply reuse everything**

Your existing Gastronorm containers, your trays, chafing dishes and inserts – they can all be used without any problem.

### **simply hot and cold**

According to the time of day and choice of dishes – you choose whether to have them perfectly chilled in the ice tray or keep them consistently warm by using the appropriate heating elements.

### **simply neat and organised**

The compact arrangement saves you a huge amount of space, even at the busiest times – everything is always tidy, appetising and clean.

### **simply says it all**

The attractive presentation using picture inserts or boards not only provides a see-at-a-glance guide to the dishes, it also whets the appetite and creates an advertising space. Even when the containers are closed.

**Grundreling L**

basic rail L  
 support 3 barres de base L  
 soporte principal L  
 unità base L

passend für 3 Rahmen und 3 Bilder oder Tafeln, bestehend aus 1 x Reling, 2 x Fuß, 2 x Abdeckkappe /  
 fits for 3 frames and 3 pictures or boards, consisting of 1 x rail, 2 x foot, 2 x cap



Cromargan® / stainless 18/10

Höhe	height	Ø Fuß	Ø base
cm	in.	cm	in.
22,6	9	20	8

06.2410.6040

**Erweiterungsreling L**

extension rail L  
 support 3 barres supplémentaire L  
 soporte adicional L  
 estensione L

passend für 3 Rahmen und 3 Bilder oder Tafeln, bestehend aus 1 x Reling, 1 x Fuß, 2 x Abdeckkappe /  
 fits for 3 frames and 3 pictures or boards, consisting of 1 x rail, 1 x foot, 2 x cap



Cromargan® / stainless 18/10

Höhe	height	Ø Fuß	Ø base
cm	in.	cm	in.
22,6	9	20	8

06.2412.6040

Ersatzteil / spare part:

Reling L / rail L 06.2410.6042

Fuß / foot 06.2410.6041

Abdeckkappe / cap 06.2410.6043

**Grundreling M**

basic rail M  
 support 3 barres de base M  
 soporte principal M  
 unità base M

passend für 2 Rahmen und 2 Bilder oder Tafeln, bestehend aus 1 x Reling, 2 x Fuß, 2 x Abdeckkappe /  
 fits for 2 frames and 2 pictures or boards, consisting of 1 x rail, 2 x foot, 2 x cap



Cromargan® / stainless 18/10

Höhe	height	Ø Fuß	Ø base
cm	in.	cm	in.
22,6	9	20	8

06.2411.6040



### Erweiterungsreling M

extension rail M  
support 3 barres supplémentaire M  
soporte adicional M  
estensione M

passend für 2 Rahmen und 2 Bilder oder Tafeln, bestehend aus 1 x Reling, 1 x Fuß, 2 x Abdeckkappe /  
fits for 2 frames and 2 pictures or boards, consisting of 1 x rail, 1 x foot, 2 x cap



Cromargan® / stainless 18/10

Höhe cm	height in.	Ø Fuß cm	Ø base in.
22,6	9	20	8

**06.2413.6040**

Ersatzteil / spare part:

Fuß / foot

06.2410.6041

Abdeckkappe / cap

06.2410.6043

### Chafing Dish, GN 1/1

Chafing Dish, GN 1/1  
Chafing Dish, GN 1/1  
Chafing Dish, GN 1/1  
Chafing Dish, GN 1/1

passend für Einsätze bis Tiefe 10 cm. Bitte Heizelement und Einsätze separat bestellen. Passende Einsätze s. Chafing Dish Katalog /  
fitting for inserts up to depth 4 in. Please order heating element and inserts separately. Suitable inserts in chafing dish catalogue

GN 1/1, Klappdeckel, elektrisch beheizbar /  
GN 1/1, cover, electrically heated

Cromargan® / stainless 18/10

komplett ohne Einsätze / complete w/o inserts

Höhe Deckel hochgeklappt cm	height cover lifted in.	Größe mit Deckel und Griff cm	size w. cover a. handle in.
61	24	62 x 34,5 x 20	24 <sup>1</sup> / <sub>2</sub> x 13 <sup>1</sup> / <sub>2</sub> x 8

**06.2446.6040**

Zubehör / accessory:

Heizelement 230 V / 600 W /

heating element 230 V / 600 W

55.0097.6044

Heizelement 120 V / 600 W /

heating element 120 V / 600 W

55.0097.9990

Heizelement 230 V / 700 W mit Regler /

heating element 230 V / 700 W heat adjustable

06.3286.6046





**Chafing Dish, GN 1/1**

Chafing Dish, GN 1/1  
 Chafing Dish, GN 1/1  
 Chafing Dish, GN 1/1  
 Chafing Dish, GN 1/1

passend für Einsätze bis Tiefe 10 cm. Bitte Heizelement und Einsätze separat bestellen. Passende Einsätze s. Chafing Dish Katalog / fitting for inserts up to depth 4 in.

Please order heating element and inserts separately. Suitable inserts in chafing dish catalogue

GN 1/1, Klappdeckel, elektrisch beheizbar / GN 1/1, cover, electrically heated

Cromargan® / stainless 18/10

komplett ohne Einsätze / complete w/o inserts

Höhe Deckel hochgeklappt	height cover lifted	Größe mit Deckel und Griff	size w. cover a. handle	
cm	in.	cm	in.	
74	29	62 x 34,5 x 20	24 1/2 x 13 1/2 x 8	<b>06.2423.6040</b>

Zubehör / accessory:

Heizelement 230 V / 600 W / heating element 230 V / 600 W	55.0097.6044
Heizelement 120 V / 600 W / heating element 120 V / 600 W	55.0097.9990
Heizelement 230 V / 700 W mit Regler / heating element 230 V / 700 W heat adjustable	06.3286.6046



**Heizelement**

heating element  
 plaque électrique  
 placa calentadora  
 piastra riscaldante

für WMF Chafing Dishes GN 1/1 und GN 2/3, VDE geprüft / suitable for WMF chafing dishes GN 1/1 and GN 2/3, VDE proved

Größe	size
cm	in.
25 x 20	9 3/4 x 7 3/4

Heizelement 230 V / 600 W / heating element 230 V / 600 W	55.0097.6044
Heizelement 120 V / 600 W / heating element 120 V / 600 W	55.0097.9990
Heizelement 230 V / 700 W mit Regler / heating element 230 V / 700 W heat adjustable	06.3286.6046
Heizelement 120 V / 700 W mit Regler / heating element 120 V / 700 W heat adjustable	55.0136.9990



### Rahmen, GN 1/1 mittel

frame, GN 1/1 medium  
cadre, GN 1/1 moyen  
marco, GN 1/1 medio  
telaio, GN 1/1 medio

passend für Einsätze GN 1/1, GN 2/3, GN 1/2, GN 1/3, GN 2/4  
(max. 6,5 cm tief) /  
fitting for inserts GN 1/1, GN 2/3, GN 1/2, GN 1/3, GN 2/4  
(max. 2 1/2 in. deep)

Cromargan® / stainless 18/10

Höhe	height
cm	in.
10	4

06.2420.6040



### Rahmen, GN 1/1 hoch

frame, GN 1/1 high  
cadre, GN 1/1 haut  
marco, GN 1/1 alto  
telaio, GN 1/1 alto

passend für Einsätze GN 1/1, GN 2/3, GN 1/2, GN 1/3, GN 2/4  
(max. 10 cm tief) /  
fitting for inserts GN 1/1, GN 2/3, GN 1/2, GN 1/3, GN 2/4  
(max. 4 in. deep)

Cromargan® / stainless 18/10

Höhe	height
cm	in.
16	6 1/4

06.2421.6040



### Rahmen, GN 1/2 mittel

frame, GN 1/2 medium  
cadre, GN 1/2 moyen  
marco, GN 1/2 medio  
telaio, GN 1/2 medio

passend für Einsätze GN 1/2 (max. 6,5 cm tief) /  
fitting for inserts GN 1/2 (max. 2 1/2 in. deep)

Cromargan® / stainless 18/10

Höhe	height
cm	in.
10	4

06.2417.6040



**Rahmen, GN 1/2 hoch**

frame, GN 1/2 high  
cadre, GN 1/2 haut  
marco, GN 1/2 alto  
telaio, GN 1/2 alto

passend für Einsätze GN 1/2 (max. 10 cm tief) /  
fitting for inserts GN 1/2 (max. 4 in. deep)

Cromargan® / stainless 18/10

Höhe	height
cm	in.
16	6 <sup>3</sup> / <sub>4</sub>

06.2418.6040



**Platte, GN 1/1, CORIAN®**

platter, GN 1/1, CORIAN®  
planche pour recipient, GN 1/1, CORIAN®  
fuente, GN 1/1, CORIAN®  
piatto, GN 1/1, CORIAN®

passend auf alle GN 1/1 Rahmen und Plattenständer niedrig/hoch /  
fitting on all GN 1/1 frames and on tray stands low/high

spülmaschinenfest /  
dishwasher-safe

CORIAN®

Größe	size
cm	in.
53 x 32,5	20 <sup>3</sup> / <sub>4</sub> x 12 <sup>3</sup> / <sub>4</sub>

06.2431.9990



**Tablett, rechteckig, Gastronorm**

servicing tray, rectangular, Gastronorm  
plateau de service, rectangulaire, Gastronorm  
bandeja, rectangular, Gastronorm  
vassoio, rettangolare, Gastronorm

Passend auf alle GN 1/1 Rahmen von combiNation buffet /  
fitting on all GN 1/1 frames of combiNation buffet

GN 1/1, stapelbar, rechteckig, schnittfest, spülmaschinenfest /  
GN 1/1, stackable, rectangular, resistant against cutting, dishwasher-safe

Kunststoff, Cromargan® - Griffe /

high quality plastic, handle stainless 18/10

Größe	size
cm	in.
53 x 32,5	20 <sup>3</sup> / <sub>4</sub> x 12 <sup>3</sup> / <sub>4</sub>

06.7683.6040



### Platte, GN Kunststoff

platter Gastronorm, acrylic  
 planche Gastronorm pour recipient, plastique  
 fuente Gastronorm, plastico transparente  
 piatto Gastronorm, materiale sintetico

schnittfest, spülmaschinenfest /  
 resistant against cutting, dishwasher-safe

Kunststoff / plastic

	Größe cm	size in.	
GN 1/2*	32,5 x 26,5	12 <sup>3</sup> / <sub>4</sub> x 10 <sup>1</sup> / <sub>2</sub>	<b>06.2433.9990</b>
GN 1/1**	53 x 32,5	20 <sup>3</sup> / <sub>4</sub> x 12 <sup>3</sup> / <sub>4</sub>	<b>06.2432.9990</b>

\* Passend auf alle GN 1/2 Rahmen /  
 fitting on all GN 1/2 frames

\*\* Passend auf alle GN 1/1 Rahmen und Plattenständer niedrig/hoch /  
 fitting on all GN 1/1 frames and tray stands low/high



### Tablett, Gastronorm

serving tray, Gastronorm  
 plateau de service, Gastronorm  
 bandeja, Gastronorm  
 vassoio, Gastronorm

rechteckig /  
 rectangular

Cromargan® / stainless 18/10

	Größe cm	size in.	
GN 1/2*	32,5 x 26,5	12 <sup>3</sup> / <sub>4</sub> x 10 <sup>1</sup> / <sub>2</sub>	<b>06.7658.6040</b>
GN 1/1**	53 x 32,5	20 <sup>3</sup> / <sub>4</sub> x 12 <sup>3</sup> / <sub>4</sub>	<b>06.7660.6040</b>

\* Passend auf alle GN 1/2 Rahmen / fitting on all GN 1/2 frames

\*\* Passend auf alle GN 1/1 Rahmen und auf Plattenständer niedrig/hoch /  
 fitting on all GN 1/1 frames and on tray stands low/high



### Tablett, Gastronorm, CLASSIC

serving tray, Gastronorm  
 plateau de service, Gastronorm  
 bandeja, Gastronorm  
 vassoio, Gastronorm

Passend auf alle GN 1/1 Rahmen von combiNation buffet /  
 fitting on all GN 1/1 frames of combiNation buffet

GN 1/1, rechteckig /  
 GN 1/1, rectangular

Größe cm	size in.	Cromargan® stainless 18/10	versilbert silverplated
53 x 32,5	20 <sup>3</sup> / <sub>4</sub> x 12 <sup>3</sup> / <sub>4</sub>	<b>06.7849.6040</b>	<b>19.7849.6440</b>

**Abdeckhaube**

cover for trays  
 cloche pour plateaux  
 campana para bandejas  
 coperchio adatto per vassoio

mit 2 seitlichen Eingriffen, passend für Tablett GN 1/1 ohne Griffe und Plattenständer niedrig/hoch /  
 with two side openings, fitting for trays GN 1/1 without handles and on tray stands low/high

Kunststoff glasklar, Griff verchromt /  
 high quality plastic, handle chrome plated

Größe	size
cm	in.
55,5 x 35 x 14,5	21 <sup>3</sup> / <sub>4</sub> x 13 <sup>3</sup> / <sub>4</sub> x 5 <sup>3</sup> / <sub>4</sub>

06.2937.6040

**Eiswanne, Gastronorm 1/1**

ice tray, Gastronorm 1/1  
 bac réfrigérant, Gastronorm 1/1  
 bandeja para hielo, Gastronorm 1/1  
 vasca per ghiaccio, Gastronorm 1/1

Passend in GN 1/1 Rahmen mittel und hoch. Es passen Brillen und Tablett. GN-Behälter passen **nicht** in die Eiswannen. /  
 Fitting for frames GN 1/1 medium and high. Suitable for all insert holders and trays. GN-inserts do **not** fit in the ice trays.

GN 1/1, spülmaschinenfest /  
 GN 1/1, dishwasher-safe

ABS Kunststoff schwarz / ABS black plastic

	Größe	size	
	cm	in.	
①	53 x 32,5 x 7,5	20 <sup>3</sup> / <sub>4</sub> x 12 <sup>3</sup> / <sub>4</sub> x 3	06.2426.9990
②	53 x 32,5 x 14	20 <sup>3</sup> / <sub>4</sub> x 12 <sup>3</sup> / <sub>4</sub> x 5 <sup>1</sup> / <sub>2</sub>	06.2450.9990





### Eiswanne, Gastronorm 1/2

ice tray, Gastronorm 1/2  
 bac réfrigérant, Gastronorm 1/2  
 bandeja para hielo, Gastronorm 1/2  
 vasca per ghiaccio, Gastronorm 1/2

Passend in GN 1/2 Rahmen mittel und hoch. Es passen Brillen und Tablets bis max. GN 1/2. GN-Behälter passen **nicht** in die Eiswannen. /  
 Fitting for frames GN 1/2 medium and high. Suitable for all insert holders and trays till max. GN 1/2. GN-inserts do **not** fit in the ice trays.

GN 1/2, spülmaschinenfest /  
 GN 1/2, dishwasher-safe

ABS Kunststoff schwarz / ABS black plastic

	Größe cm	size in.	
①	32,5 x 26,5 x 7,5	12 <sup>3</sup> / <sub>4</sub> x 10 <sup>1</sup> / <sub>2</sub> x 3	06.2452.9990
②	32,5 x 26,5 x 14	12 <sup>3</sup> / <sub>4</sub> x 10 <sup>1</sup> / <sub>2</sub> x 5 <sup>1</sup> / <sub>2</sub>	06.2451.9990



### Kühlakku, Gastronorm 1/2

cooling block, Gastronorm 1/2  
 brique réfrigérante, Gastronorm 1/2  
 acumulador refrigerador, Gastronorm 1/2  
 tavoletta per il ghiaccio, Gastronorm 1/2

1 Stück für Eiswannen GN 1/2, 2 Stück für Eiswannen GN 1/1 und Plattenständer niedrig/hoch /  
 1 pc. for ice trays GN 1/2, 2 pcs. for ice trays GN 1/1 and tray stands low/high

Kunststoff mit Kühlflüssigkeit / plastic with cooling liquid

Größe cm	size in.	
25,5 x 20,3 x 3,2	10 x 8 x 1 <sup>1</sup> / <sub>4</sub>	60.3065.9990



### Glaskrug

glass pitcher  
 broc en verre  
 jarra de cristal  
 brocca di vetro

2 Stück passen in die Eiswannen GN 1/2, 4 St. in GN 1/1 /  
 2 pcs. fitting in ice trays GN 1/2, 4 St. in GN 1/1

Glas / glass

Höhe cm	height in.	Inhalt Ltr.	cap. oz.	
30	11 <sup>3</sup> / <sub>4</sub>	2	67	09.4117.2000

**Brille, GN 1/1 für 2 Gefäße**

insert holder, GN 1/1 for 2 inserts  
 support, GN 1/1 pour 2 becs  
 soporte, GN 1/1 para 2 recipientes  
 supporto, GN 1/1 per 2 contenitori

Passend auf alle GN 1/1 Rahmen und auf Eiswannen GN 1/1.  
 Mögliche Einsätze: Glasschale Ø 23 cm, große Porzellankugel /  
 Fitting on all GN 1/1 frames and on ice trays GN 1/1.  
 Suitable inserts: glass bowl Ø 9 in., porcelain bowl XL

2 Ausschnitte Ø je 22,2 cm, spülmaschinenfest /  
 2 cut outs Ø 8<sup>3</sup>/<sub>4</sub> in. each, dishwasher-safe

Cromargan® / stainless 18/10

Größe	size
cm	in.
53 x 33,3	20 <sup>3</sup> / <sub>4</sub> x 13

06.2436.6040

**Brille, GN 1/2 für 1 Gefäß**

insert holder, GN 1/2 for 1 insert  
 support, GN 1/2 pour 1 bec  
 soporte, GN 1/2 para 1 recipiente  
 supporto, GN 1/2 per 1 contenitore

Passend auf alle GN 1/2 Rahmen und auf Eiswannen GN 1/2.  
 Mögliche Einsätze: Glasschale Ø 23 cm, große Porzellankugel /  
 Fitting on all GN 1/2 frames and on ice trays GN 1/2.  
 Suitable inserts: glass bowl Ø 9 in., porcelain bowl XL

1 Ausschnitt Ø 22,2 cm, spülmaschinenfest /  
 1 cut out Ø 8<sup>3</sup>/<sub>4</sub> in. each, dishwasher-safe

Cromargan® / stainless 18/10

Größe	size
cm	in.
33,3 x 26,5	13 x 10 <sup>1</sup> / <sub>2</sub>

06.2434.6040

**Porzellankugel, groß**

porcelain bowl, XL  
 boule porcelaine, XL  
 bola de porcelana, XL  
 sfera in porcellana, XL

Passend in Etagërenring, in alle Brillen mit großen Ausschnitten  
 Ø 22,2 cm auf mittleren und hohen Rahmen. /  
 Fitting in etagere ring, in all insert holders with big cut out  
 Ø 8<sup>3</sup>/<sub>4</sub> in. on frames medium and high.

Inhalt	cap.
Ltr.	oz.
3,5	122,5

60.3060.9990



### Glasschale, 23 cm

glass bowl, 23 cm  
 bol à verre, 23 cm  
 depósitos de cristal, 23 cm  
 interno in vetro, 23 cm

Passend in Eiswannen mit Crush Eis, in alle Brillen mit großen Ausschnitten Ø 22,2 cm auf mittleren und hohen Rahmen. / Fitting in ice trays with crush ice, in all insert holders with big cut out Ø 8<sup>3</sup>/<sub>4</sub> in. on frames medium and high.

Ø	Ø
cm	in.
23	9

19.9999.8673



### Glasschale, 12 cm

glass bowl, 12 cm  
 bol à verre, 12 cm  
 depósitos de cristal, 12 cm  
 interno in vetro, 12 cm

Glas / glass

Ø	Ø
cm	in.
12	4 <sup>3</sup> / <sub>4</sub>

19.9999.8672



### Porzellankugel, klein

porcelain bowl, S  
 boule porcelaine, S  
 bola de porcelana, S  
 sfera in porcellana, S

Porzellan, weiß / porcelain, white

Inhalt	cap.
Ltr.	oz.
0,5	17,5

60.3058.9990



### Beilagenschale

bowl for ingredients  
 bol de acero  
 bol de acero  
 interno in vetro

Cromargan® / stainless 18/10

Ø	Ø
cm	in.
11,4	4 <sup>1</sup> / <sub>2</sub>

06.0315.6040

**Dressingbehälter**

dressing insert  
garniture pour saucière  
recipiente para salsas  
contenitore per salsa

Passend in Besteckbaum 06.2448.6040 und in Eiswannen tief von combiNation buffet. /  
Fitting in utensil holder 06.2448.6040 and in ice trays deep of combiNation buffet.

Cromargan® / stainless 18/10

Inhalt	cap.	Ø	Ø
Ltr.	oz.	cm	in.
1	35	11,4	4 1/2

06.1762.6043

**Etagère, 2-tlg.**

etagere, 2 parts  
étagère, 2 anneaux  
frutero articulado, de 2 brazos  
etagere, 2 anelli

zum Aufschrauben auf die Reling, passend für Glasschalen Ø 20 cm, Porzellankugel XL, Tablett 06.3014.6041 /  
to attach to the rail, fitting for glass bowl Ø 8 in., porcelain bowl XL, serving tray 06.3014.6041

Cromargan® / stainless 18/10

Höhe	height
cm	in.
28,4	11 1/4

06.2441.6040

**Glasschale, 20 cm**

glass bowl, 20 cm  
coupe verre glasskin, 20 cm  
depósitos de cristal, 20 cm  
interno in vetro, 20 cm

passend in Etagère 06.3010.6040, 06.3011.6040, 06.4394.6040, 06.2441.6040 combiNation buffet /  
fitting in etagere 06.3010.6040, 06.3011.6040, 06.4394.6040, 06.2441.6040 combiNation buffet

Höhe	height	Ø	Ø
cm	in.	cm	in.
8,5	3 1/4	20	8

19.9999.8642

**Früchtekorb**

fruit basket  
panier à fruits  
frutero  
fruttiera

passend in Etagère 06.3010.6040, 06.3011.6040, 06.2441.6040 combiNation buffet nur in Verbindung mit Kühlbehälter 06.3014.6045 (bitte separat bestellen) /  
fitting together with cooler 06.3014.6045 (please order separately) in etagere 06.3010.6040, 06.3011.6040, 06.2441.6040 combiNation buffet

Cromargan® / stainless 18/10

Höhe	height	Ø	Ø
cm	in.	cm	in.
22,5	8 3/4	26	10 1/4

06.6521.6040



### Tablett, rund

service tray, round  
plateau de service, rond  
bandeja, redonda  
vassoio, rontondo

passend in Etagère 06.3010.6040, 06.3011.6040, 06.2441.6040  
combiNation buffet /  
fitting in etagere 06.3010.6040, 06.3011.6040, 06.2441.6040  
combiNation buffet

Cromargan® / stainless 18/10

Ø außen cm	outer Ø in.	Ø innen cm	Ø inside in.
29,5	11½	24,5	9¾

06.3014.6041



### Kühlbehälter, mit Kühlpellet

cooler, with cooling element  
coupe réfrigérante, avec élément réfrigérante  
recipiente, con acumulador de frio  
base, con elemento refrigerante

passend in Etagère 06.3010.6040, 06.3011.6040, 06.2441.6040  
combiNation buffet zum Kühlen von Tablett 06.3014.6041 /  
fitting in etagere 06.3010.6040, 06.3011.6040, 06.2441.6040  
combiNation buffet to cool tray 06.3014.6041

Cromargan® / stainless 18/10

Ø cm	Ø in.
19	7½

06.3014.6044

Ersatzteil / spare part:

Kühlpellet / cooling element

19.9999.5850



### Besteckbaum, 3-tlg.

utensil holder, 3 parts  
étagère à couverts, en 3 parties  
árbol cubertero, de 3 piezas  
portapostate con stuttura ad albero, a 3 ramificazioni

zum Aufstecken **auf** freien **Bolzen** am Anfang oder Ende der Reling.  
Inkl. Einsätze.

Fassungsvermögen je Behälter ca. 50 Besteckteile /  
to put **on** available **adapters** at begin either end of the rail. Inclusive  
inserts. Capacity per insert approx 50 utensils

Cromargan® / stainless 18/10

Höhe cm	height in.	Ø Ring cm	Ø ring in.
53	20¾	11,5	4½

06.2448.6040

Ersatzteil / spare part:

Dressingbehälter / dressing insert

06.1762.6043



### Hygieneschutz

hygienic cover  
 plateau pléxiglas  
 protector higiéniico  
 copertura

bestehend aus 2 Seitenteilen und 1 Schutzplatte, demontierbar /  
 consisting of 2 side bars and 1 protective cover, can be dismantled

höhenverstellbar /  
 height adjustable

Cromargan®, Kunststoff transparent /  
 stainless 18/10, transparent plastic cover

Breite	width	Höhe	height	Tiefe	outer Ø	
cm	in.	cm	in.	cm	in.	
110*	43 <sup>1</sup> / <sub>4</sub> *	49 - 69	19 <sup>1</sup> / <sub>4</sub> - 27 <sup>1</sup> / <sub>4</sub>	46	18	<b>06.2444.6040</b>
76**	30**	49 - 69	19 <sup>1</sup> / <sub>4</sub> - 27 <sup>1</sup> / <sub>4</sub>	46	18	<b>06.2445.6040</b>

\* für Reling L mit 3 Rahmen / for rail L with 3 frames

\*\* für Reling M mit 2 Rahmen / for rail M with 2 frames



### Schreibtafel S

blackboard S  
 tableau S  
 pizarra S  
 lavagna S

beidseitig mit Kreide oder Tafelstiften (Illumigraphen) beschreibbar,  
 zum Aufstecken auf Reling /  
 double sided, to be written on with chalk or graphic pens, to attach to the rail

Kunststoff / plastic

Größe	size	
cm	in.	
32,8 x 30	13 x 11 <sup>3</sup> / <sub>4</sub>	<b>06.2427.9990</b>

**06.2427.9990**



### Plexiglashülle S

plexi glass frame S  
 plateau pléxiglas S  
 marco de metacrilato S  
 porta immagini in plexi S

an 3 Seiten offen zum Einlegen von Bildmotiven, zum Aufstecken auf Reling /  
 open 3 sides to insert graphics, to attach to the rail

Kunststoff / plastic

Größe	size	
cm	in.	
32,5 x 30	12 <sup>3</sup> / <sub>4</sub> x 11 <sup>3</sup> / <sub>4</sub>	<b>06.2428.9990</b>

**06.2428.9990**



■ **combiNation buffet**

»Müsli / Quark / Obst«

Cereals, Yogurt, Fruits

Metall-Teile aus Cromargan®, insgesamt 85 cm lang, Tischtiefe mindestens 75 cm  
Metal parts from stainless 18/10, total length 33 1/2 in.,  
Minimum depth of the table 29 1/4 in.

Bestehend aus / comprising:

**Grundreling M / basic rail M** 06.2411.6040

**Etagère / etagere** 06.2441.6040

**2 x Glasschale / glass bowl**  
zu Etagère Ø 20 cm / Ø 8 in. 19.9999.8642

**2 x Plexihülle S / plexi glass frame** für Bilder / for pictures 06.2428.9990

**2 x Rahmen / frame** GN 1/1 mittel /medium 06.2420.6040

**Tablett / serving tray 18/10 GN 1/1** 06.7660.6040

**Eiswanne / ice tray**  
(o. Abb. / without picture) 06.2426.9990

**Brille / insert holder** GN 1/1  
2 Ausschnitte / 2 cut outs 06.2436.6040

**2 x Glasschale / glass bowl** Ø 23 cm / Ø 9 in. 19.9999.8673



■ **combiNation buffet**

»Vorspeisen / Kalte Speisen«

Starters, Cold Dishes

Metall-Teile aus Cromargan®, insgesamt 120 cm lang,  
Tischtiefe mindestens 75 cm  
Metal parts from stainless 18/10, total length 47 1/4 in.,  
Minimum depth of the table 29 1/4 in.

Bestehend aus / consisting of:

**Grundreling L / basic rail L** 06.2410.6040

**2 x Plexihülle S / plexi glass frame**  
für Bilder / for pictures 06.2428.9990

**Schreibttafel / blackboard** 06.2427.9990

**3 x Rahmen / frame** GN 1/1  
mittel / medium 06.2420.6040

**Eiswanne / ice tray plastic**  
(o. Abb. / without picture) 06.2426.9990

**Kunststoffplatte / platter acrylic** GN 1/1 06.2432.9990

**Corianplatte / platter Corian** GN 1/1 06.2431.9990

**Tablett / serving tray 18/10** GN 1/1 06.7660.6040





■ **combiNation buffet**

»Chafing Dish«

Metall-Teile aus Cromargan®, insgesamt 120 cm lang,  
Tischtiefe mindestens 75 cm  
Metal parts from stainless 18/10, total length 47 1/4 in.,  
Minimum depth of the table 29 1/4 in.  
Bestehend aus / consisting of:

<b>Grundreling L / basic rail L</b>		06.2410.6040
<b>Schreibtafel / blackboard</b>		06.2427.9990
<b>2 x Plexihülle S / plexi glass frame</b> für Bilder / for pictures		06.2428.9990
<b>3 x Chafing Dish</b>	GN 1/1	
ohne Einsatz, ohne Heizelement without insert, without heating element		06.2423.6040
<b>3 x Heizelement / heating element</b> 230 V / 600 Watt		55.0097.6044
<b>2 x Porzellan Einsatz / porcelain insert</b>	GN 1/2 - 65	60.3045.9990
<b>2 x Porzellaneinsatz / porcelain insert</b>	GN 1/1 - 65	60.3044.9990
<b>3 x Porzellan Einsatz / porcelain insert</b>	GN 1/3-20	60.3055.9990

■ Welche Länge hat Ihr künftiges Buffet?  
– Die Maße.

Jede Grundreling ist mit jeder Erweiterungsreling kombinierbar. Bei jedem Anbau an eine Grundreling **A** oder **B** muss also die Länge der zusätzlichen Erweiterungsrelings **C** oder **D** dazu addiert werden.

Tischtiefe mindestens 70 cm!

■ How long is your future buffet?  
– Measurements.

Each basic rail can be combined with each extension rail. For each attachment to a basic rail **A** or **B**, therefore, the length of the additional extension rails **C** or **D** should be added.

Depth of table minimum 70 cm / 27½ in!

■ Quelle est la largeur de votre futur buffet?  
– Les dimensions.

chaque support 2 barres de base peut être combiné avec chaque support 2 barres supplémentaire. Il faut donc additionner la largeur des supports supplémentaires **A** ou **B** pour chaque support supplémentaire ajouté à un support de base **C** ou **D**.

Profondeur de table minimum 70 cm!

■ ¿Qué ancho tiene su futuro mostrador?  
– Las medidas.

Cada barandilla base se puede combinar con cada barandilla de ampliación. Por lo tanto, en cada montaje a una barandilla base **A** o **B** se tiene que sumar la cantidad multiplicada por el ancho de las barandillas de ampliación **C** o **D** adicionales.

La profundidad de la mesa por lo menos 70 cm!

■ Quale larghezza avrà il vostro futuro buffet?  
– Le quote.

Ogni reling base può essere combinato con ogni reling di estensione. Per ogni montaggio supplementare su un reling base **A** o **B** si deve aggiungere il numero x larghezza dei reling di estensione supplementari **C** o **D**.

Profondità del tavolo minimum 70 cm!



Maße und Beispiele / examples and measures:

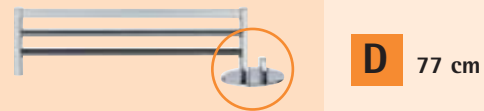
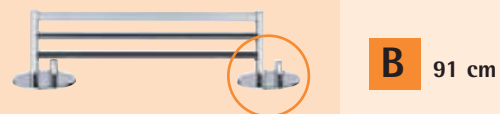

$$\begin{aligned} A + C \\ &= 126 + 112 \\ &= \underline{238 \text{ cm}} \end{aligned}$$



$$\begin{aligned} A + (2 \times D) \\ &= 126 + (2 \times 77) \\ &= \underline{280 \text{ cm}} \end{aligned}$$



$$\begin{aligned} B + (2 \times C) \\ &= 91 + (2 \times 112) \\ &= \underline{315 \text{ cm}} \end{aligned}$$

**A** Grundreling L

Basic rail L  
Support 3 barres de base L  
Soporte principal L  
Unità base L

**B** Grundreling M

Basic rail M  
Support 3 barres de base M  
Soporte principal M  
Unità base M

**C** Erweiterungsreling L

Extension rail L  
Support 3 barres supplémentaire L  
Soporte adicional L  
Estensione L

**D** Erweiterungsreling M

Extension rail M  
Support 3 barres supplémentaire M  
Soporte adicional M  
Estensione M

**Das Prinzip  
CHANGE**  
principle of  
CHANGE

**Variabel und stilsicher**  
Variable, with a clear  
sense of style

**Produktvarianten**  
range of products



CEREALIENDISPENSER  
CEREAL DISPENSER



SAFT- /MILCHDISPENSER  
JUICE- /MILK DISPENSER



CHAFING DISHES



COFFEE URNS

**Designvarianten**  
range of design



BASIC



MANHATTAN

**Produktvorteile**

Individuelle Lösungen sind die Stärke der WMF Collection CHANGE. Variabel und stilsicher harmonisiert alles mit jeder Einrichtung.

**Starke Typen**

Chafing Dishes, Dispenser für Saft, Milch und Cerealien oder Coffee Urns, es passt alles zusammen.

**Traditionelle Qualität**

Qualität und Funktionalität aus Tradition stehen auch hier ganz oben.

**Material und Verarbeitung**

Hochwertiges Cromargan® ist je nach Modell mattiert oder poliert und teilweise um vergoldete Zierelemente ergänzt. Die Cerealien-Röhre besteht aus transparentem PMMA, alle anderen Kunststoffteile aus schwarzem POM. Also absolut geruchsneutral und lebensmittelgeeignet.

**Advantages of the products**

Custom solutions are the WMF CHANGE collection's strong point. Variable and stylish, it harmonises with any decor.

**Perfect match**

Everything fits together: Chafing dishes, coffee urns, juice-, milk- and cereal dispensers.

**Traditional quality**

Quality and functionality born in tradition is our top priority.

**Material and finish**

High-grade Cromargan® / stainless 18/10 is either satin finished or polished, according to the model. Some models are decorated with gold plate. The cereal chutes are made from clear PMMA. All other plastic parts are black POM. They are totally odourless and food safe.



PALAST



Sonderausführung  
auf Anfrage

Special design  
on request



# Chafing Dish HOT & FRESH

**Frischer,  
flexibler,  
funktioneller  
... induktiv!**

more freshness,  
more flexibility,  
more function  
... inductive!

Außergewöhnliches Design, flexibel und mit hoher Funktionalität. WMF HOT & FRESH Chafing Dishes verfügen über viele Produktvorteile: Hitzebeständige Griffe, gastro-nomiegerechtes Material sowie umfangreiches Zubehör. Und die Produkte passen perfekt in die WMF CHANGE-Kollektion.

Outstanding design, flexibility and a high level of functionality, WMF HOT & FRESH chafing dishes also have other product benefits, including heat-resistant handles, catering-grade material and an extensive range of accessories. And they still match your current style as the products coordinate perfectly with the WMF CHANGE Collection!



CHANGE,  
rund / round

CHANGE,  
GN 2/3



MANHATTAN



BASIC



PALAST Sonderausführung auf Anfrage  
Special Design on request

## Steht über allem!

So bleiben Ihre Speisen überall heiß und appetitlich. WMF Chafing Dishes HOT & FRESH sind induktionsfähige Warmhaltegeräte und erfüllen Ihren Job auch auf den gängigen Wärmequellen wie Heizplatten und Brennstoff-dosen.

## Universal

So your food remains hot and appetising throughout. WMF HOT & FRESH chafing dishes not only meet the demand for chafing dishes suitable for induction systems but also perform well with standard heat sources; hotplates and sterno systems.



Direkt auf den  
Induktionsherd  
inductive  
cooking



Gestell Variante  
alternativ zu CHANGE  
Alternative frame to  
buffet stand CHANGE







Was erwarten Sie von Ihren Chafing Dishes? Ansprechendes Design? Top-Qualität? Perfektes Handling?

Die Serie WMF HOT & FRESH bietet Ihnen deutlich mehr. Sie begeistert durch den verkapselten Transtherm®-Boden, den transparenten Glasdeckel und ein intelligentes Kondenswasser-rücklaufsystem. Ganz gleich, ob GN 2/3 oder rund.

What do you expect from your chafing dishes? An attractive design? Top quality? Perfect handling?

The WMF HOT & FRESH range offers you perceptibly more. The encapsulated Transtherm® base, the transparent glass lid and an intelligent condensation recirculating system will convince you; whether in GN 2/3 or round.

**Ganz soft.  
Ganz oft.**

Qualität made in Germany: Die Deckellösung macht das Öffnen und Schließen des Chafing Dish zum Vergnügen.

Jeder WMF HOT & FRESH Chafing Dish ist mit einem transparenten Glasdeckel ausgestattet, so haben Sie immer einen Blick auf die Speisen. Der Deckel lässt sich spielend leicht öffnen und in verschiedenen Stufen einrasten. Noch einfacher ist das Schließen: Der Lauf des Deckels wird optimal gedämpft. Dafür sorgt die in Deutschland entwickelte, besonders langlebige Bremse.

**Smooth operation.  
Over and over again.**

German-made quality: the lid solution makes opening and closing the chafing dish a pleasure.

Every WMF HOT & FRESH chafing dish is equipped with a transparent glass lid. That provides a clear view of the food, even when closed. It's so easy to open, and it engages at various opening angles. Closing it is even easier: the lid movement is controlled by a long-life brake mechanism developed in Germany.



# Chafing Dish HOT & FRESH



## Zubehör Accessories

**Besteckablage / Tray/cutlery holder, Cromargan®**  
06.3539.6040

**Schale für Besteckablage / Porcelain bowl, Porzellan, weiß / porcelain, white**  
60.3540.9990

**Chafing Dish Besteck / cutlery, Cromargan®, Länge 32,5 cm, length in. 12 3/4**  
Löffel / spoon 12.8381.6041  
Gabel / fork 12.8381.6042

**Chafing Dish Besteck / cutlery, Cromargan®, Länge 26 cm, length in. 10 1/4**  
Löffel / spoon 12.8386.6041  
Gabel / fork 12.8386.6042

**Zange / tongs, Cromargan®, Länge 31 cm, length 31 cm/in.12 1/4**  
12.8341.6040

**Porzellan-Einsatz, rund / Porcelain insert round,**  
Tiefe 70 mm, ø 33,5 cm / depth 70 mm / 2 3/4 in. Ø 33,5 cm / 13 1/4 in.  
60.3072.9990

**Porzellan-Einsatz, rund geteilt / Porcelain insert round, divided**  
Tiefe 70 mm, ø 33,5 cm / depth 70 mm / 2 3/4 in. Ø 33,5 cm / 13 1/4 in.  
60.3073.9990



### Einsatz Cromargan®, rund, Insert Cromargan®, round

Höhe cm	height in.	Inhalt Ltr.	cap. oz.	ø	in.	
8	3 1/4	5	175	33,4	13 1/4	06.2083.6034
10,5	4 1/4	6,5	227,5	33,4	13 1/4	06.2083.6033

### Brennstoffdosen / solid alcohol

Großpackung 36 Stk., Inhalt 0,2l je Dose, large package 36 pcs. each tin 0,2 l / 7 oz.  
60.3002.0690

### Brennstoffdosenhalter / burner holder

für alle Gestelle GN 1/1 und HOT & FRESH / for stands GN 1/1 and HOT & FRESH  
Maße 26 x 20 x 8 cm / 10 1/4 x 8 x 3 1/4 in.  
06.3322.6039

### Heizelement mit Regler / Heating element, heat adjustable

für alle Gestelle GN 2/3 und rund / for stands GN 2/3 and round  
230 V / 700 W, 25 x 20 cm / 9 3/4 x 8 in.  
06.3286.6046  
120 V / 700 W, 25 x 20 cm / 9 3/4 x 8 in.  
55.0136.9990

### Heizelement, selbstregelnd / Heating element

für alle Gestelle GN 2/3 und rund / for stands GN 2/3 and round  
140-250 V / 220 W, 25 x 20 cm / 9 3/4 x 8 in.  
55.0095.6044  
120 V / 220 W, 25 x 20 cm / 9 3/4 x 8 in.  
55.0135.9990



**Suppenmarmite Cromargan®, rund / Soup tureen Cromargan®, round, ø 34 cm/13½ in.**

9,0 Ltr. / 315 oz.	Topf mit Aufliegedeckel / pot with normal lid	06.3297.6040
	Einsatzring / ring	06.2087.6044
4,5 Ltr. / 157,5 oz.	Topf für Aufliegedeckel / pot for normal lid	06.2007.6041
	Aufliegedeckel / lid normal for normal lid	06.2098.6042
	Einsatzring / ring	55.0068.6040
4,5 Ltr. / 157,5 oz.	Topf für Scharnierdeckel / pot for hinged lid	06.2007.9991
	Scharnierdeckel / hinged lid	06.2007.9992
	Einsatzring / ring	55.0068.6040

**Suppenmarmite Cromargan®, GN 2/3 / Soup tureen Cromargan®, GN 2/3, 36x33 cm/14¼x13 in.**

9,0 Ltr. / 315 oz.	Topf mit Aufliegedeckel / pot with normal lid	06.3297.6040
	Einsatzring / ring	06.2094.6044
4,5 Ltr. / 157,5 oz.	Topf für Aufliegedeckel / pot for normal lid	06.2007.6041
	Aufliegedeckel / lid normal for normal lid	06.2098.6042
	Einsatzring / ring	06.3301.6044
4,5 Ltr. / 157,5 oz.	Topf für Scharnierdeckel / pot for hinged lid	06.2007.9991
	Scharnierdeckel / hinged lid	06.2007.9992
	Einsatzring / ring	06.3301.6044

**Porzellan-Einsatz / Porcelain insert  
Chafing Dish GN**

GN 1/3	Tiefe 20 mm	depth 20 mm / ¾ in.	60.3055.9990
GN 1/3	Tiefe 65 mm	depth 65 mm / 2½ in.	60.3047.9990
GN 2/3	Tiefe 20 mm	depth 20 mm / ¾ in.	60.3056.9990
GN 2/3	Tiefe 65 mm	depth 65 mm / 2½ in.	60.3046.9990

**Edelstahl-Einsatz / Insert Cromargan®  
Chafing Dish GN**

GN 1/3	Tiefe 65 mm	depth 65 mm / 2½ in.	19.9955.0577
GN 1/3	Tiefe 100 mm	depth 100 mm / 4 in.	19.9955.0578
GN 2/3	Tiefe 65 mm	depth 65 mm / 2½ in.	19.9955.0585
GN 2/3	Tiefe 100 mm	depth 100 mm / 4 in.	19.9955.0586





**Chafing Dish, „Basic“, rund  
HOT & FRESH**

Chafing Dish, „Basic“, round  
Chafing Dish, „Basic“, rond  
Chafing Dish, „Basic“, redondo  
Chafing Dish, „Basic“, rotondo

passend für Einsätze bis Tiefe 10 cm, induktionsgeeignet, alternativ mit Heizplatte und Brennstoff beheizbar, Glasdeckel mit Bremse abnehmbar, Bügelgriff / fitting for inserts up to depth 10 cm / 4in., inductive, electrically and sterno heating possible, glass lid with brake removable, bow handle

Cromargan®, Glas / stainless 18/10, glass

Höhe	height	Ø	Ø
cm	in.	cm	in.
19	7½	39	15¼

55.0001.6040



**Chafing Dish, „Manhattan“, rund  
HOT & FRESH**

Chafing Dish, „Manhattan“, round  
Chafing Dish, „Manhattan“, rond  
Chafing Dish, „Manhattan“, redondo  
Chafing Dish, „Manhattan“, rotondo

passend für Einsätze bis Tiefe 10 cm, induktionsgeeignet, alternativ mit Heizplatte und Brennstoff beheizbar, Glasdeckel mit Bremse abnehmbar, Griff 4-Kantprofil (mattiert) / fitting for inserts up to depth 10 cm / 4in., inductive, electrically and sterno heating possible, glass lid with brake removable, handle profile 4-cornered (satin finished)

Cromargan®, Glas / stainless 18/10, glass

Höhe	height	Ø	Ø
cm	in.	cm	in.
19	7½	39	15¼

55.0020.6040



**Chafing Dish, „Basic“, GN 2/3  
HOT & FRESH**

Chafing Dish, „Basic“, GN 2/3  
Chafing Dish, „Basic“, GN 2/3  
Chafing Dish, „Basic“, GN 2/3  
Chafing Dish, „Basic“, GN 2/3

passend für Einsätze bis Tiefe 10 cm, induktionsgeeignet, alternativ mit Heizplatte und Brennstoff beheizbar, Glasdeckel mit Bremse abnehmbar, Bügelgriff / fitting for inserts up to depth 10 cm / 4 in., inductive, electrically and sterno heating possible, glass lid with brake removable, bow handle

Cromargan®, Glas / stainless 18/10, glass

Größe	size
cm	in.
37 x 45 x 19	14½ x 17¾ x 7½

55.0002.6040



### Chafing Dish, „Manhattan“, GN 2/3

#### HOT & FRESH

Chafing Dish, „Manhattan“, GN 2/3  
 Chafing Dish, „Manhattan“, GN 2/3  
 Chafing Dish, „Manhattan“, GN 2/3  
 Chafing Dish, „Manhattan“, GN 2/3



passend für Einsätze bis Tiefe 10 cm, induktionsgeeignet, alternativ mit Heizplatte und Brennstoff beheizbar, Glasdeckel mit Bremse abnehmbar, Griff 4-Kantprofil (mattiert) / fitting for inserts up to depth 10 cm / 4 in., inductive, electrically and sterno heating possible, glass lid with brake removable, handle profile 4-cornered (satin finished)

Cromargan®, Glas / stainless 18/10, glass

Größe	size
cm	in.
37 x 45 x 19	14 <sup>1</sup> / <sub>2</sub> x 17 <sup>3</sup> / <sub>4</sub> x 7 <sup>1</sup> / <sub>2</sub>

55.0021.6040

### Buffetgestell, „Basic“, rund

#### HOT & FRESH

frame, „Basic“, round  
 bati, „Basic“, rond  
 soporte buffet, „Basic“, redondo  
 telaio, „Basic“, rotondo



für Heizplatte und Brennstoff, Füße Rundprofil / for electrically and sterno heating, feet profile round

Cromargan® / stainless 18/10

Höhe	height	Ø	Ø
cm	in.	cm	in.
24	9 <sup>1</sup> / <sub>2</sub>	47	18 <sup>1</sup> / <sub>2</sub>

55.0007.6040

### Buffetgestell, „Manhattan“, rund

#### HOT & FRESH

frame, „Manhattan“, round  
 bati, „Manhattan“, rond  
 soporte buffet, „Manhattan“, redondo  
 telaio, „Manhattan“, rotondo



für Heizplatte und Brennstoff, Füße 4-Kantprofil (mattiert) / for electrically and sterno heating, feet profile 4-cornered (satin finished)

Cromargan® / stainless 18/10

Höhe	height	Ø	Ø
cm	in.	cm	in.
24	9 <sup>1</sup> / <sub>2</sub>	47	18 <sup>1</sup> / <sub>2</sub>

55.0008.6040



**Buffetgestell, „Basic“, GN 2/3**

**HOT & FRESH**

frame, „Basic“, GN 2/3

bati, „Basic“, GN 2/3

soporte buffet, „Basic“, GN 2/3

telaio, „Basic“, GN 2/3

für Heizplatte und Brennstoff, Füße Rundprofil /  
for electrically and sterno heating, feet profile round

Cromargan® / stainless 18/10

Größe	size
cm	in.
44 x 40 x 24	17 1/4 x 15 3/4 x 9 1/2

55.0012.6040



**Buffetgestell, „Manhattan“, GN 2/3**

**HOT & FRESH**

frame, „Manhattan“, GN 2/3

bati, „Manhattan“, GN 2/3

soporte buffet, „Manhattan“, GN 2/3

telaio, „Manhattan“, GN 2/3

für Heizplatte und Brennstoff, Füße 4-Kantprofil (mattiert) /  
for electrically and sterno heating, feet profile 4-cornered (satin finished)

Cromargan® / stainless 18/10

Größe	size
cm	in.
44 x 40 x 24	17 1/4 x 15 3/4 x 9 1/2

55.0013.6040



**Buffetgestell, rund**

**HOT & FRESH**

frame, round

bati, rond

soporte buffet, redondo

telaio, rotondo

für Heizplatte und Brennstoff, passend zu allen runden Chafing Dishes  
HOT & FRESH /

for electrically and sterno heating, fitting for all round chafing dishes  
HOT & FRESH

Cromargan® / stainless 18/10

Höhe	height	Ø	Ø
cm	in.	cm	in.
17	6 3/4	39	15 1/4

55.0005.6040





**Buffetgestell, GN  $\frac{2}{3}$**

**HOT & FRESH**

frame, GN  $\frac{2}{3}$

bati, GN  $\frac{2}{3}$

soporte buffet, GN  $\frac{2}{3}$

telaio, GN  $\frac{2}{3}$

für Heizplatte und Brennstoff, passend zu allen Chafing Dishes GN  $\frac{2}{3}$   
HOT & FRESH /

for electrically and sterno heating, fitting for all chafing dishes GN  $\frac{2}{3}$   
HOT & FRESH

Cromargan® / stainless 18/10

Größe

size

cm

in.

37 x 40 x 17

14 $\frac{1}{2}$  x 15 $\frac{3}{4}$  x 6 $\frac{3}{4}$

**55.0006.6040**

# Chafing Dish CHANGE chafing dish CHANGE

Immer eine Hand frei  
keeping one hand free

Produktvarianten  
range of products



CHAFING DISHES GN 1/1

CHAFING DISHES  
rund / round



## einfach bedienbar

Ob im GN 1/1-Format oder rund, die Chafing Dishes der Kollektion »CHANGE« haben eines gemeinsam: Ein leicht und fast geräuschlos mit einer Hand zu öffnender Rolltop-Deckel. Das wird jeder schätzen, der einmal versucht hat, mit der einen Hand den Deckel zu halten, in der anderen den Teller – und dann überlegt, wie er sich jetzt bedienen soll?

## simply to handle

Both the GN 1/1 size and the round chafing dishes in the »CHANGE« line have one thing in common: a roll-top lid which runs almost silently and is easy to open with just one hand. That will be appreciated by anyone who has ever tried to keep the lid open with one hand while holding a plate in the other... and then wondered how to reach the food!



## Produktvorteile

## Advantages of the products

Auch bei dem runden Chafing Dish ist durch die **spezielle Kabelführung** gewährleistet, dass der Deckel beim Einsatz eines elektrischen Heizteiles problemlos geöffnet werden kann.

The round chafing dish now includes a **special flex clip**, allowing the lid to be opened freely when using electric heating.



Die **Griffe sind hitzeisoliert** und somit auch im Betrieb ohne den Einsatz von Tüchern und sonstigen Hilfsmitteln zu öffnen.

The **handles are insulated** to allow the lids to be opened for serving without using a cloth or other holder.



Der im Deckelrand integrierte **Kondenswasserrücklauf** verhindert das Tropfen und dadurch unschöne Kondenswasser-Pfützen auf dem Tisch.

The **condensation return** built into the edge of the lid prevents drips and unsightly puddles on the tabletop.



Alle Modelle (außer Manhattan) sind platzsparend **stapelbar**.

All the models (except Manhattan) are **stackable** to save space.



Der Deckel des GN 1/1 ist mit 2 hochwertigen **Scheibenbremsen** ausgestattet, die einfach zu justieren und einzustellen sind.

The lid of the GN 1/1 is fitted with two **high-class disk brakes**. They can be setting up and adjusted simply.



Der Deckel ist komplett versenkbar und schwingt exzentrisch um den Brennstoffdosenhalter oder um die Heizplatte. Die Speisen sind komplett zugänglich und die Belüftung der Flamme ist stets gewährleistet. Der Deckel der runden Chafing Dishes kann in drei Positionen, der des GN 1/1-Modelles stufenlos arretiert werden.

The lid is fully roll-top and is offset to the burner holder or hotplate when opened. When the lid is fully opened, the food is easily accessible while still ensuring adequate ventilation for the flame. The round chafing dish lid can be opened to three different positions and the GN 1/1 model lid is infinitely adjustable.





**Chafing Dish, „Basic“**

**CHANGE**

Chafing Dish, „Basic“  
 Chafing Dish, „Basic“  
 Chafing Dish, „Basic“  
 Chafing Dish, „Basic“

passend für Einsätze bis Tiefe 10 cm /  
 fitting for inserts up to depth 4 in.

GN 1/1, Rolltopdeckel, elektrisch und Brennstoff beheizbar, Bremse nachstellbar, Deckel versenkbar /  
 GN 1/1, full rolltop cover, electrically and sterno heated, adjustable brake, cover immersible

Cromargan®, Füße Rundprofil, Bügelgriffe /  
 stainless 18/10, feet profil round, with bow handles  
 ohne Einsätze / w/o inserts

Höhe cm	height in.	Größe mit Griffen cm	size with handles in.	
45,6	18	74 x 38	28 1/4 x 15	<b>06.3333.6041</b>

Zubehör / accessory:

Heizelement 230 V / 600 W / heating element 230 V / 600 W	55.0097.6044
Heizelement 120 V / 600 W / heating element 120 V / 600 W	55.0097.9990
Heizelement 230 V / 700 W mit Regler / heating element 230 V / 700 W heat adjustable	06.3286.6046
Brennstoffdosenhalter / burner holder	06.3322.6039



**Chafing Dish, „Metropolitan“**

**CHANGE**

Chafing Dish, „Metropolitan“  
 Chafing Dish, „Metropolitan“  
 Chafing Dish, „Metropolitan“  
 Chafing Dish, „Metropolitan“

passend für Einsätze bis Tiefe 10 cm /  
 fitting for inserts up to depth 4 in.

GN 1/1, Rolltopdeckel, elektrisch und Brennstoff beheizbar, Bremse nachstellbar, Deckel versenkbar /  
 GN 1/1, full rolltop cover, electrically and sterno heated, adjustable brake, cover immersible

Cromargan®, Füße Rundprofil, Kugelgriffe /  
 stainless 18/10, feet profil round, with knob handles  
 ohne Einsätze / w/o inserts

Höhe cm	height in.	Größe mit Griffen cm	size with handles in.	
45,6	18	74 x 38	28 1/4 x 15	<b>06.3330.6041</b>

Zubehör / accessory:

Heizelement 230 V / 600 W / heating element 230 V / 600 W	55.0097.6044
Heizelement 120 V / 600 W / heating element 120 V / 600 W	55.0097.9990
Heizelement 230 V / 700 W mit Regler / heating element 230 V / 700 W heat adjustable	06.3286.6046
Brennstoffdosenhalter / burner holder	06.3322.6039

Bitte Heizelement und Brennstoffdosenhalter separat bestellen. Einzelteile (Seite 181) /  
 Please order heating elements and burner holder separately. Spare parts (page 181)

### Chafing Dish, „Metropolitan“, rund CHANGE

Chafing Dish, „Metropolitan“, round  
Chafing Dish, „Metropolitan“, rond  
Chafing Dish, „Metropolitan“, redondo  
Chafing Dish, „Metropolitan“, rotondo

passend für Einsätze bis Tiefe 10 cm /  
fitting for inserts up to depth 4 in.

rund, Rolltopdeckel, elektrisch und Brennstoff beheizbar, Deckel  
versenkbar /  
round, full rolltop cover, electrically and sterno heated, cover  
immersible

Cromargan®, Füße Rundprofil, Kugelgriff /  
stainless 18/10, feet profil round, with knob handle

Höhe	height	Ø	Ø	
cm	in.	cm	in.	
46	18	43	17	<b>06.3940.6041</b>

Zubehör / accessory:

Heizelement 140-250 V / 270 W / heating element 140-250 V / 270 W	55.0096.6044
Heizelement 100-120 V / 230 W / heating element 100-120 V / 230 W	55.0096.9990
Heizelement 230 V / 550 W mit Regler / heating element 230 V / 550 W heat adjustable	06.2095.6046
Brennstoffdosenhalter / burner holder	06.3940.6039



### Chafing Dish, „Manhattan“ CHANGE

Chafing Dish, „Manhattan“  
Chafing Dish, „Manhattan“  
Chafing Dish, „Manhattan“  
Chafing Dish, „Manhattan“

passend für Einsätze bis Tiefe 10 cm /  
fitting for inserts up to depth 4 in.

GN 1/1, Rolltopdeckel, elektrisch und Brennstoff beheizbar, Bremse  
nachstellbar, Deckel versenkbar /  
GN 1/1, full rolltop cover, electrically and sterno heated, adjustable  
brake, cover immersible

Cromargan®, teilmattiert, Füße und Griffe im 4-Kantprofil /  
stainless 18/10, partly satin finished, handles and feet profil 4-cornered  
ohne Einsätze / w/o inserts

Höhe	height	Größe mit Griffen	size with handles	
cm	in.	cm	in.	
45,6	18	74 x 38	28 1/4 x 15	<b>06.3335.6041</b>

Zubehör / accessory:

Heizelement 230 V / 600 W / heating element 230 V / 600 W	55.0097.6044
Heizelement 120 V / 600 W / heating element 120 V / 600 W	55.0097.9990
Heizelement 230 V / 700 W mit Regler / heating element 230 V / 700 W heat adjustable	06.3286.6046
Brennstoffdosenhalter / burner holder	06.3322.6039







**Chafing Dish, „Manhattan“, rund  
CHANGE**

Chafing Dish, „Manhattan“, round  
Chafing Dish, „Manhattan“, rond  
Chafing Dish, „Manhattan“, redondo  
Chafing Dish, „Manhattan“, rotondo

passend für Einsätze bis Tiefe 10 cm /  
fitting for inserts up to depth 4 in.

rund, Rolltopdeckel, elektrisch und Brennstoff beheizbar, Deckel  
versenkbar /  
round, full rolltop cover, electrically and sterno heated, cover  
immersible

Cromargan®, teilmattiert, FüÙe und Griff im 4-Kantprofil /  
stainless 18/10, partly satin finished, handle and feet profil 4-cornered

Höhe cm	height in.	Ø cm	Ø in.	
46	18	43	17	<b>06.3945.6041</b>

Zubehör / accessory:

Heizelement 140-250 V / 270 W / heating element 140-250 V / 270 W	55.0096.6044
Heizelement 100-120 V / 230 W / heating element 100-120 V / 230 W	55.0096.9990
Heizelement 230 V / 550 W mit Regler / heating element 230 V / 550 W heat adjustable	06.2095.6046
Brennstoffdosenhalter / burner holder	06.3940.6039



Breite Aufliegerahmen: 35,5 mm  
width supporting frame: 1 1/8 in.



**Chafing Dish, Thekeneinbau  
STANDARD**

Chafing Dish, to be built into counter  
Chafing Dish, pour montage en comptoir  
Chafing Dish, encastrado  
Chafing Dish, emportable

passend für Einsätze bis Tiefe 10 cm /  
fitting for inserts up to depth 4 in.

GN 1/1, Rolltopdeckel, elektrisch beheizbar /  
GN 1/1, full rolltop cover, electrically heated

Cromargan® / stainless 18/10  
ohne Einsätze / w/o inserts

Höhe cm	height in.	Größe cm	size in.	
17	6 3/4	65 x 47	25 5/8 x 18 1/2	<b>06.3266.6041</b>

Zubehör / accessory:

Heizelement 230 V / 600 W / heating element 230 V / 600 W	55.0097.6044
Heizelement 120 V / 600 W / heating element 120 V / 600 W	55.0097.9990
Heizelement 230 V / 700 W mit Regler / heating element 230 V / 700 W heat adjustable	06.3286.6046

AusschnittmaÙe / cut out size



Bitte Heizelement und Brennstoffdosenhalter separat bestellen. Einzelteile (Seite 181) /  
Please order heating elements and burner holder separately. Spare parts (page 181)



### Portions-Chafing Dish

#### STANDARD

Chafing Dish, S  
 Chafing Dish, S  
 Chafing Dish, S  
 Chafing Dish, S

passend für alle handelsüblichen Porzellanteller mit  $\varnothing$  23 cm, beheizbar mit Teelichte (nicht enthalten) / suitable for all porcelain plates  $\varnothing$  9 in., heated by tealights (not included)

rund, Rolltopdeckel, mit 2 Teelichten beheizbar / round, full rolltop cover, heated by 2 tealights

Cromargan® / stainless 18/10  
 ohne Einsätze / w/o inserts

Höhe	height	$\varnothing$	$\varnothing$
cm	in.	cm	in.
29	11 1/2	26	10 1/4

06.3306.6040



Breite Auflegerahmen: 40 mm  
 width supporting frame: 1 1/2 in.



Draufsicht / top view

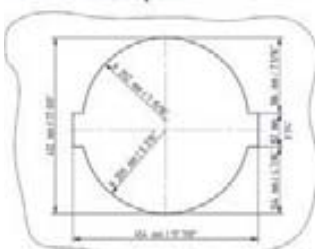

Ausschnittmaße / cut out size

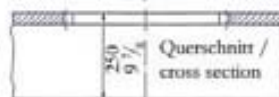

### Chafing Dish, Thekeneinbau

#### STANDARD

Chafing Dish, to be built into counter  
 Chafing Dish, pour montage en comptoir  
 Chafing Dish, encastrado  
 Chafing Dish, emportable

passend für Einsätze bis Tiefe 10 cm / fitting for inserts up to depth 4 in.

rund, Rolltopdeckel, elektrisch beheizbar / round, full rolltop cover, electrically heated

Cromargan® / stainless 18/10  
 ohne Hezelement, ohne Einsätze / w/o heating element, w/o inserts

Höhe	height	$\varnothing$	$\varnothing$
cm	in.	cm	in.
18,3	7 1/4	48	18 7/8

06.3290.6041

Zubehör / accessory:

Hezelement 140-250 V / 270 W / heating element 140-250 V / 270 W 55.0096.6044

Hezelement 100-120 V / 230 W / heating element 100-120 V / 230 W 55.0096.9990

Hezelement 230 V / 550 W mit Regler / heating element 230 V / 550 W heat adjustable 06.2095.6046



**Chafing Dish, mit Domdeckel**

**ECONOMY**

Chafing Dish, conventional standard cover

Chafing Dish, avec couvercle standard

Chafing Dish, tapa estándar

Chafing Dish, con coperchio standard

passend für Einsätze bis Tiefe 10 cm, Deckel zu allen 4 Seiten

hochstellbar /

fitting for inserts up to depth 4 in., lid can be raised on all 4 sides

GN 1/1, stapelbar, Domdeckel, elektrisch und Brennstoff beheizbar /

GN 1/1, stackable, conventional standard cover, electrically and sterno heated

Cromargan® matt / stainless 18/10 satin finished

ohne Einsätze / w/o inserts

Höhe mit Griff	height with handle	Größe mit Griffen	size with handles	
cm	in.	cm	in.	
32	12 1/2	62 x 35	24 1/2 x 13 3/4	<b>06.3322.6230</b>

Zubehör / accessory:

Heizelement 230 V / 600 W /

heating element 230 V / 600 W

55.0097.6044

Heizelement 120 V / 600 W /

heating element 120 V / 600 W

55.0097.9990

Heizelement 230 V / 700 W mit Regler /

heating element 230 V / 700 W heat adjustable

06.3286.6046

Brennstoffdosenhalter / burner holder

06.3322.6039

Heizelement 230 V / 1000 W /

heating element 230 V / 1000 W

06.2082.6044

Adapter für Elektroheizteil /

holder for heating element

06.3272.6039



**Chafing Dish, mit Klappdeckel**

**ECONOMY**

Chafing Dish, 1/2 rolltop cover

Chafing Dish, avec couvercle rabattable

Chafing Dish, con tapa abatible

Chafing Dish, con coperchio ribaltabile

passend für Einsätze bis Tiefe 10 cm /

fitting for inserts up to depth 4 in.

GN 1/1, Klappdeckel, elektrisch und Brennstoff beheizbar /

GN 1/1, cover, electrically and sterno heated

Cromargan® matt / stainless 18/10 satin finished

ohne Einsätze / w/o inserts

Höhe mit Griff	height with handle	Größe mit Griffen	size with handles	
cm	in.	cm	in.	
36	14 1/4	62 x 35	24 1/2 x 13 3/4	<b>06.3324.6230</b>

Zubehör / accessory:

Heizelement 230 V / 600 W /

heating element 230 V / 600 W

55.0097.6044

Heizelement 120 V / 600 W /

heating element 120 V / 600 W

55.0097.9990

Heizelement 230 V / 700 W mit Regler /

heating element 230 V / 700 W heat adjustable

06.3286.6046

Brennstoffdosenhalter / burner holder

06.3322.6039

Heizelement 230 V / 1000 W /

heating element 230 V / 1000 W

06.2082.6044

Adapter für Elektroheizteil /

holder for heating element

06.3272.6039



Bitte Heizelement und Brennstoffdosenhalter separat bestellen. Einzelteile (Seite 181) /

Please order heating elements and burner holder separately. Spare parts (page 181)

Ersatzteile für WMF Chafing Dishes  
Spare parts for WMF Chafing Dishes

Bezeichnung Designation	Artikel-Nummer Order no.	Cromargan Stainless 18/10	Teilvergoldet partly gold plated	Gestell/Rahmen frame	Deckel cover	Wasserbad- wanne water pan	Einbaurahmen frame	Brennstoffhalter burner holder	Heizelement heating element	Heizelement mit Regler heating element adjustable
Thekeneinbau GN 1/1	06.3266.6040	•			06.3330.6042	06.3319.6231	06.3266.6045		55.0097.6044	06.3286.6046
Thekeneinbau, rund	06.3290.6040	•			06.3283.6042	06.2003.6041	06.3290.6045		55.0096.6044	06.2095.6046
Economy GN 1/1	06.3322.6230	•		06.3322.6235	06.3322.6232	06.3322.6231		06.3322.6039	55.0097.6044	06.3286.6046
Economy GN 1/1	06.3324.6230	•		06.3322.6235	06.3324.6232	06.3322.6231		06.3322.6039	55.0097.6044	06.3286.6046
Metropolitan GN 1/1	06.3330.6040	•		06.3330.6045	06.3330.6042	06.3319.6231		06.3322.6039	55.0097.6044	06.3286.6046
Palast GN 1/1	06.3331.6210		•	06.3331.6215	06.3331.6212	06.3319.6231		06.3322.6039	55.0097.6044	06.3286.6046
Basic GN 1/1	06.3333.6040	•		06.3333.6045	06.3333.6042	06.3319.6231		06.3322.6039	55.0097.6044	06.3286.6046
Manhattan GN 1/1	06.3335.6040	•		06.3335.6045	06.3335.6042	06.3319.6231		06.3322.6039	55.0097.6044	06.3286.6046
Metropolitan rund	06.3940.6040	•		06.3940.6045	06.3940.6042	06.2003.6041		06.3940.6039	55.0096.6044	06.2095.6046
Palast rund	06.3941.6210		•	06.3941.6215	06.3941.6212	06.2003.6041		06.3940.6039	55.0096.6044	06.2095.6046
Manhattan rund	06.3945.6040	•		06.3945.6045	06.3945.6042	06.2003.6041		06.3940.6039	55.0096.6044	06.2095.6046
combiNation Buffet GN 1/1	06.2446.6040	•			06.2446.6042	06.3322.6231			55.0097.6044	06.3286.6046
combiNation Buffet GN 1/1	06.2423.6040	•				06.3322.6231			55.0097.6044	06.3286.6046
combiNation Buffet GN 1/1	06.2442.6040	•				06.3322.6231			55.0097.6044	06.3286.6046



**Suppenmarmite**

soup tureen  
marmite à potage  
recipiente sopa  
zuppiera

passend in Chafing Dish GN 1/1 und HOT & FRESH GN 2/3 /  
fitting for chafing dish GN 1/1 and HOT & FRESH GN 2/3

Cromargan® / stainless 18/10

Größe	size	Inhalt	cap.
cm	in.	Ltr.	oz.
36 x 33	14 1/4 x 13	4,5	157,5

Einsatzring / ring	06.3301.6044
Topf f. Aufliegedeckel / pot f. normal lid	06.2007.6041
Aufliegedeckel / normal lid	06.2098.6042
Topf f. Scharnierdeckel / pot f. hinged lid	06.2007.9991
Scharnierdeckel / hinged lid	06.2007.9992

\* Artikel einzeln bestellen / please order articles separately



**Suppenmarmite**

soup tureen  
marmite à potage  
recipiente sopa  
zuppiera

passend in Chafing Dish GN 1/1 und HOT & FRESH GN 2/3 /  
fitting for chafing dish GN 1/1 and HOT & FRESH GN 2/3

Cromargan® / stainless 18/10

Größe	size	Inhalt	cap.
cm	in.	Ltr.	oz.
36 x 33	14 1/4 x 13	9	315

Topf mit Deckel / pot with cover	06.3297.6040
Einsatzring / ring	06.2094.6044

\* Artikel einzeln bestellen / please order articles separately



**Porzellan-Einsatz**

porcelain insert  
intérieur en porcelaine  
interior porcelana  
interno in porcellana

passend in Chafing Dish GN 1/1 und 2/3 /  
fitting for chafing dish GN 1/1 and 2/3

Cromargan®, Porzellan / stainless 18/10, porcelain

Inhalt	cap.	Ø	Ø
Ltr.	oz.	cm	in.
4	140	29	11 1/2

Einsatz / insert	60.3001.0690
Einsatzring / ring	06.2094.6044

\* Artikel einzeln bestellen / please order articles separately





### Suppenstation, GN 1/1 mit Deckel

soup tureen, GN 1/1 with lid  
 marmite à potage, GN 1/1 avec couvercle  
 recipiente sopa, GN 1/1 con tapa  
 zuppiera, GN 1/1 con coperchio

passend in Chafing Dish GN 1/1 /  
 fitting for chafing dish GN 1/1

Größe	size	Inhalt	cap.
cm	in.	Ltr.	oz.
53 x 32,5	20 <sup>3</sup> / <sub>4</sub> x 12 <sup>3</sup> / <sub>4</sub>	2 x 4,5	2 x 157,5

#### Ausführung I /quality I

Cromargan® / stainless 18/10  
 1 Abdeckplatte, 2 Suppentöpfe mit Scharnierdeckel / 1 insert  
 plate and 2 soup tureens with hinged lid  
 Komplett / complete

06.2007.9990

#### Ausführung II /quality II

Cromargan® / stainless 18/10  
 1 Abdeckplatte und 2 Suppentöpfe mit Deckel / 1 insert plate  
 and 2 soup tureens with lid  
 Komplett / complete

06.2007.6040

Ersatzteil / spare part:

Topf f. Scharnierdeckel / pot f. hinged lid 06.2007.9991

Topf f. Aufliegedeckel / pot f. normal lid 06.2007.6041

Scharnierdeckel / hinged lid 06.2007.9992

Aufliegedeckel / normal lid 06.2098.6042

Brille / insert holder 06.2098.6044



### Suppenmarmite

soup tureen  
 marmite à potage  
 soper para chafing dish  
 zuppiera per chafing dish

passend in alle großen runden WMF Chafing Dishes und in den Chafing  
 Dish HOT & FRESH rund. In 2 Versionen bestellbar: Ring + Topf f.  
 Aufliegedeckel + Aufliegedeckel / Ring + Topf für Scharnierdeckel +  
 Scharnierdeckel. /

fitting in all big round WMF chafing dishes and in Chafing Dish HOT  
 & FRESH round. To be ordered in 2 versions: ring + pot f. normal lid +  
 cover / ring + pot f. hinged lid + hinged cover.

Cromargan® / stainless 18/10

Inhalt	cap.	Ø	Ø
Ltr.	oz.	cm	in.
4,5	157,5	34	13 <sup>1</sup> / <sub>2</sub>

Ring / ring

55.0068.6040

Topf f. Aufliegedeckel / pot f. normal lid

06.2007.6041

Aufliegedeckel / normal lid

06.2098.6042

Topf f. Scharnierdeckel / pot f. hinged lid

06.2007.9991

Scharnierdeckel / hinged lid

06.2007.9992

\* Artikel einzeln bestellen / please order articles separately



**Suppenmarmite**

soup tureen  
marmite à potage  
sopera para chafing dish  
zuppiera per chafing dish

passend in alle großen runden Chafing Dishes von WMF und den Chafing Dish HOT & FRESH rund / fitting for all big round WMF chafing dishes and in chafing dish HOT & FRESH round

Cromargan® / stainless 18/10

Inhalt	cap.	Ø	Ø
Ltr.	oz.	cm	in.
9	315	34	13 1/2

Topf mit Deckel / pot with cover **06.3297.6040**  
Ring / ring **06.2087.6044**

\* Artikel einzeln bestellen / please order articles separately



**Porzellan-Einsatz**

porcelain insert  
intérieur en porcelaine  
interior porcelana  
interno in porcellana

passend in alle großen runden Chafing Dishes von WMF / fitting for all big round WMF chafing dishes

Cromargan®, Porzellan / stainless 18/10, porcelain

Inhalt	cap.	Ø	Ø
Ltr.	oz.	cm	in.
4	140	34	13 1/2

Einsatz / insert **60.3001.0690**  
Ring / ring **06.2087.6044**

\* Artikel einzeln bestellen / please order articles separately



**Einsatz für Chafing Dish**

insert for chafing dish  
intérieur pour chafing dish  
deposito para chafing dish  
inserto piatto chafing dish

passend in alle großen runden Chafing Dishes von WMF / fitting for all big round WMF chafing dishes

Cromargan® / stainless 18/10

Höhe	height	Inhalt	cap.	Ø	Ø	
cm	in.	Ltr.	oz.	cm	in.	
8	3 1/4	5	175	33,4	13 1/4	<b>06.2083.6034</b>
10,5	4 1/4	6,5	227,5	33,4	13 1/4	<b>06.2083.6033</b>

### Porzellan-Einsatz, geteilt

porcelain insert, divided  
 intérieur en porcelaine, divisé  
 recipiente de porcelana, dividido  
 interno in porcellana, ripartito

passend in alle großen runden Chafing Dishes von WMF /  
 fitting for all big round WMF chafing dishes



Porzellan / porcelain

Höhe	height	Inhalt	cap.	Ø	Ø	
cm	in.	Ltr.	oz.	cm	in.	
7	2 <sup>3</sup> / <sub>4</sub>	2 x 1,75	2 x 62	33,5	13 <sup>1</sup> / <sub>4</sub>	<b>60.3073.9990</b>

### Porzellan-Einsatz

porcelain insert  
 intérieur en porcelaine  
 interior porcelana  
 interno in porcellana

passend in alle großen runden Chafing Dishes von WMF /  
 fitting for all big round WMF chafing dishes



Porzellan / porcelain

Höhe	height	Inhalt	cap.	Ø	Ø	
cm	in.	Ltr.	oz.	cm	in.	
7	2 <sup>3</sup> / <sub>4</sub>	3,75	131,3	33,5	13 <sup>1</sup> / <sub>4</sub>	<b>60.3072.9990</b>

### Porzellan-Einsätze

porcelain insert  
 intérieur en porcelaine  
 interior de porcelana  
 interno in porcellana

Porzellan weiß / porcelain white

Inhalt	cap.	Ø	Ø	
Ltr.	oz.	cm	in.	
1,5	52,5	20	8	<b>60.3004.0690</b>



### Platte, rund

platter, round  
 plat, rond  
 fuente, redonda  
 vassoio, rotondo

passend in alle WMF Portions-Chafing Dishes /  
 fitting for all WMF chafing dishes small size

Cromargan® / stainless 18/10

Ø	Ø	
cm	in.	
23	9	<b>06.3306.6044</b>



**Gastronorm-Einsatz, zu Chafing Dish**

GN insert, for chafing dish

GN intérieur, pour chafing dish

GN interior, para chafing dish

GN interno, per chafing dish

Beachten: Gastronorm-Einsätze passen **nicht** in die Eiswanne von combiNation buffet, sondern nur in mittlere und hohe Rahmen! / GN inserts do **not** fit in the ice tray of combiNation buffet, but only fit in frames medium and high!

Cromargan® / stainless 18/10

Einsatz GN 1/3 / insert GN 1/3

Größe cm	size in.	Inhalt Ltr.	cap. oz.	
6,5 x 17,5 x 32,5	2 1/2 x 7 x 12 3/4	2,4	84	<b>19.9955.0577</b>
10 x 17,5 x 32,5	4 x 7 x 12 3/4	3,75	133	<b>19.9955.0578</b>

Einsatz GN 1/2 / insert GN 1/2

Größe cm	size in.	Inhalt Ltr.	cap. oz.	
6,5 x 26 x 32,5	2 1/2 x 10 1/4 x 12 3/4	3,8	133	<b>19.9955.0581</b>
10 x 26 x 32,5	4 x 10 1/4 x 12 3/4	6	210	<b>19.9955.0582</b>

Einsatz GN 2/3 / insert GN 2/3

Größe cm	size in.	Inhalt Ltr.	cap. oz.	
6,5 x 35,4 x 32,5	2 1/2 x 14 x 12 3/4	5,5	192,5	<b>19.9955.0585</b>
10 x 35,4 x 32,5	4 x 14 x 12 3/4	8,5	297,5	<b>19.9955.0586</b>

Einsatz GN 1/1 / insert GN 1/1

Größe cm	size in.	Inhalt Ltr.	cap. oz.	
6,5 x 53 x 32,5	2 1/2 x 20 3/4 x 12 3/4	8,5	297,5	<b>19.9955.0589</b>
10 x 53 x 32,5	4 x 20 3/4 x 12 3/4	13,3	465,5	<b>19.9955.0590</b>



### Porzellan-Einsatz, zu Chafing Dish

GN porcelain insert, for chafing dish

GN intérieur en intérieur, pour chafing dish

GN interior porcelana, para chafing dish

GN interno in porcellana, per chafing dish

Beachten: Gastronorm-Einsätze passen **nicht** in die Eiswanne von combiNation buffet! /

GN inserts do **not** fit in the ice tray of combiNation buffet!

Porzellan / porcelain

Einsatz GN  $\frac{1}{3}$  / insert GN  $\frac{1}{3}$

Größe cm	size in.	Inhalt Ltr.	cap. oz.	
2 x 17,5 x 32,5	$\frac{3}{4}$ x 7 x $12\frac{3}{4}$	0,4	14	<b>60.3055.9990</b>
6,5 x 17,5 x 32,5	$2\frac{1}{2}$ x 7 x $12\frac{3}{4}$	1,9	64,2	<b>60.3047.9990</b>

Einsatz GN  $\frac{1}{2}$  / insert GN  $\frac{1}{2}$

Größe cm	size in.	Inhalt Ltr.	cap. oz.	
2 x 26,5 x 32,5	$\frac{3}{4}$ x $10\frac{1}{2}$ x $12\frac{3}{4}$	0,7	24,5	<b>60.3054.9990</b>
6,5 x 26,5 x 32,5	$2\frac{1}{2}$ x $10\frac{1}{2}$ x $12\frac{3}{4}$	3,3	111,54	<b>60.3045.9990</b>

Einsatz GN  $\frac{2}{3}$  / insert GN  $\frac{2}{3}$

Größe cm	size in.	Inhalt Ltr.	cap. oz.	
2 x 35,4 x 32,5	$\frac{3}{4}$ x 14 x $12\frac{3}{4}$	0,8	28	<b>60.3056.9990</b>
6,5 x 35,4 x 32,5	$2\frac{1}{2}$ x 14 x $12\frac{3}{4}$	4,65	157,17	<b>60.3046.9990</b>

Einsatz GN  $\frac{1}{1}$  / insert GN  $\frac{1}{1}$

Größe cm	size in.	Inhalt Ltr.	cap. oz.	
2 x 53 x 32,5	$\frac{3}{4}$ x $20\frac{3}{4}$ x $12\frac{3}{4}$	1,4	49	<b>60.3053.9990</b>
6,5 x 53 x 32,5	$2\frac{1}{2}$ x $20\frac{3}{4}$ x $12\frac{3}{4}$	7,3	246,74	<b>60.3044.9990</b>

Einsatz GN  $\frac{2}{4}$  / insert GN  $\frac{2}{4}$

Größe cm	size in.	Inhalt Ltr.	cap. oz.	
6,5 x 16 x 53	$2\frac{1}{2}$ x $6\frac{1}{4}$ x $20\frac{3}{4}$	2,5	87,5	<b>60.3048.9990</b>







**Heizelement**

heating element  
 plaque électrique  
 placa calentadora  
 piastra riscaldante

für WMF Chafing Dishes GN 1/1 ohne Rolltop-Deckel /  
 suitable for all WMF chafing dishes GN 1/1 without full rolltop cover

Größe	size
cm	in.
24 x 24	9 1/2 x 9 1/2

Heizelement 230 V / 1000 W /  
 heating element 230 V / 1000 W

06.2082.6044



**Adapter für Elektroheizteil**

holder for heating element  
 adaptateur pour plaque électrique  
 adaptador para placa calentadora  
 adattatore per piastra riscaldante

zum problemlosen Einsatz von Heizelement 06.2082.6044 und  
 06.2082.9990 für WMF Chafing Dishes GN 1/1 ohne Rolltop-Deckel /  
 suitable for easy use of heating element 06.2082.6044 and  
 06.2082.9990 for all WMF chafing dishes GN 1/1 without full rolltop  
 cover

Cromargan® / stainless 18/10

Höhe	height	Größe	size
cm	in.	cm	in.
7	2 3/4	25 x 20	9 3/4 x 7 3/4

06.3272.6039



**Heizelement**

heating element  
 plaque électrique  
 placa calentadora  
 piastra riscaldante

für alle großen runden WMF Chafing Dishes, VDE geprüft /  
 suitable for all big round WMF chafing dishes, VDE proved

Größe	size
cm	in.
20 x 20	7 3/4 x 7 3/4

Heizelement 140-250 V / 270 W /  
 heating element 140-250 V / 270 W

55.0096.6044

Heizelement 100-120 V / 230 W /  
 heating element 100-120 V / 230 W

55.0096.9990

Heizelement 230 V / 550 W mit Regler /  
 heating element 230 V / 550 W heat adjustable

06.2095.6046



### Heizelement

heating element  
 plaque électrique  
 place calentadora  
 piastra riscaldante

für WMF Chafing Dishes HOT & FRESH GN  $\frac{2}{3}$  und rund /  
 suitable for WMF chafing dishes HOT & FRESH GN  $\frac{2}{3}$  and round

Größe	size
cm	in.
25 x 20	9 $\frac{3}{4}$ x 7 $\frac{3}{4}$

Heizelement, 140-250 V / 220 W /  
 heating element, 140-250 V / 220 W  
 Heizelement 120 V / 220 W /  
 heating element 120 V / 220 W

**55.0095.6044**

**55.0135.9990**



### Heizelement

heating element  
 plaque électrique  
 placa calentadora  
 piastra riscaldante

für WMF Chafing Dishes GN  $\frac{1}{1}$  und GN  $\frac{2}{3}$ , VDE geprüft /  
 suitable for WMF chafing dishes GN  $\frac{1}{1}$  and GN  $\frac{2}{3}$ , VDE proved

Größe	size
cm	in.
25 x 20	9 $\frac{3}{4}$ x 7 $\frac{3}{4}$

Heizelement 230 V / 600 W /  
 heating element 230 V / 600 W

**55.0097.6044**

Heizelement 120 V / 600 W /  
 heating element 120 V / 600 W

**55.0097.9990**

Heizelement 230 V / 700 W mit Regler /  
 heating element 230 V / 700 W heat adjustable

**06.3286.6046**

Heizelement 120 V / 700 W mit Regler /  
 heating element 120 V / 700 W heat adjustable

**55.0136.9990**



### Brennstoffdosenhalter

burner holder  
 porte brûleur  
 soporte quemador  
 fornello

zur problemlosen Umstellung von elektrischer Heizung auf Brennstoff.  
 Passend für alle WMF Chafing Dishes GN  $\frac{1}{1}$  und HOT & FRESH /  
 for uncomplicated conversion from electrical to burner heating. Fitting  
 for all WMF chafing dishes GN  $\frac{1}{1}$  and HOT & FRESH

Cromargan® / stainless 18/10

Größe	size
cm	in.
20 x 26 x 8,2	8 x 10 $\frac{1}{4}$ x 3 $\frac{1}{4}$

**06.3322.6039**



**Brennstoffdosenhalter**

burner holder  
 porte brûleur  
 soporte quemador  
 fornello

zur problemlosen Umstellung von elektrischer Heizung auf Brennstoff.  
 Passend für alle runden Chafing Dishes CHANGE /  
 for uncomplicated conversion from electrical to burner heating. Fitting  
 for all round WMF chafing dishes CHANGE

Cromargan® / stainless 18/10

Höhe	height	Größe	size	
cm	in.	cm	in.	
8,5	3 1/4	12,5 x 20	5 x 8	<b>06.3940.6039</b>



**Brennstoffdose**

solid alcohol  
 alcool solidifié  
 combustible  
 alcool solido

Großpackung 36 St. /  
 large package 36 pcs.

Inhalt	cap.
Ltr.	oz.
je Dose 0,2	each tin 7

**60.3002.0690**



**Besteckablage**

rack for utensils  
 support couverts à servir  
 soporte cubiertos servir  
 porta posante

passend in alle WMF Chafing Dishes GN 1/1 in Standard- und Economy-  
 Ausführung /  
 fitting for all WMF chafing dishes GN 1/1 design Standard and Economy

Cromargan® / stainless 18/10

Größe	size	
cm	in.	
30 x 9	12 x 3 1/2	<b>06.3296.6030</b>



### Besteckablage

rack for utensils  
support couverts à servir  
soporte cubiertos servir  
porta posante

zum Einhängen in die Rahmen aller GN 1/1 Chafing Dishes CHANGE und HOT & FRESH, kann auch ohne Chafing Dish freistehend verwendet werden. /

to hinge in the frames of all GN 1/1 chafing dishes CHANGE and HOT & FRESH, can also be used on its own without Chafing Dish.

Cromargan®, Porzellan weiß / stainless 18/10, porcelain white

Tablett/Besteckhalter / tray/cutlery holder

Größe	size	
cm	in.	
27,9 x 12 x 7,1	11 x 4 <sup>3</sup> / <sub>4</sub> x 2 <sup>3</sup> / <sub>4</sub>	<b>06.3539.6040</b>

Porzellanschale / porcelain bowl

Größe	size	
cm	in.	
21 x 8,7 x 3,25	8 <sup>1</sup> / <sub>4</sub> x 3 <sup>1</sup> / <sub>2</sub> x 1 <sup>1</sup> / <sub>4</sub>	<b>60.3540.9990</b>

\* Artikel einzeln bestellen / please order articles separately

**Chafing Dish – Besteck**

chafing dish serving set  
 service pour chafing dish  
 cubiertos para chafing dish  
 posate chafing dish

Cromargan® / stainless 18/10

Chafing Dish Gabel / chafing dish fork

Länge	length
cm	in.
26	10 <sup>1</sup> / <sub>4</sub>

12.8386.6042



Chafing Dish Löffel / chafing dish spoon

Länge	length
cm	in.
26	10 <sup>1</sup> / <sub>4</sub>

12.8386.6041



Chafing Dish Gabel / chafing dish fork

Länge	length
cm	in.
26	10 <sup>1</sup> / <sub>4</sub>

12.8249.6040



Salatgabel / salad fork

Länge	length
cm	in.
26	10 <sup>1</sup> / <sub>4</sub>

12.8343.6042



Chafing Dish Gabel / chafing dish fork

Länge	length
cm	in.
32,5	12 <sup>3</sup> / <sub>4</sub>

12.8381.6042



Chafing Dish Löffel / chafing dish spoon

Länge	length
cm	in.
32,5	12 <sup>3</sup> / <sub>4</sub>

12.8381.6041



Fleischgabel / serving fork

Länge	length
cm	in.
32,5	12 <sup>3</sup> / <sub>4</sub>

12.8382.6040



Nudellöffel / pasta serving spoon

Länge	length
cm	in.
31,5	12 <sup>1</sup> / <sub>2</sub>

12.8383.6040



Chafing Dish Gabel / chafing dish fork

Länge	length
cm	in.
39	15 <sup>1</sup> / <sub>4</sub>

12.8387.6042



Chafing Dish Löffel / chafing dish spoon

Länge	length
cm	in.
39	15 <sup>1</sup> / <sub>4</sub>

12.8387.6041







**Coffee Urn, „Basic“  
CHANGE**

coffee urn, „Basic“  
coffee urn, „Basic“  
urna de café, „Basic“  
coffee urn, „Basic“

elektrisch und mit Brennstoff beheizbar. Heizelemente (110-265 V/ 150 W) und Brennstoffhalter bitte separat bestellen. / electrically and sterno heated. Please order heating elements (110-265 V/150W) separately.

Cromargan® / stainless 18/10

Höhe	height	Inhalt	cap.	Ø	Ø	
cm	in.	Ltr.	oz.	cm	in.	
54,5	21½	10	338	26	10¼	<b>06.1520.6040</b>
63,2	25	15	507	26	10¼	<b>06.1525.6040</b>

Zubehör / accessory:

Heizelement Coffee Urn / heating element 19.9999.9879

Brennstoffdose / solid alcohol 60.3002.0690

Inhalt cap.  
Ltr. oz.  
je Dose 0,2 each tin 7

Brennstoffhalter Coffee Urn / burner holder coffee urn 06.1520.6039

Höhe	height	Ø	Ø
cm	in.	cm	in.
12,8	5	17	6¾



**Coffee Urn, „Manhattan“  
CHANGE**

coffee urn, „Manhattan“  
coffee urn, „Manhattan“  
urna de café, „Manhattan“  
coffee urn, „Manhattan“

elektrisch und mit Brennstoff beheizbar. Heizelemente (110-265 V/ 150 W) und Brennstoffhalter bitte separat bestellen. / electrically and sterno heated. Please order heating elements (110-265 V/150W) separately.

Cromargan® / stainless 18/10

Höhe	height	Inhalt	cap.	Ø	Ø	
cm	in.	Ltr.	oz.	cm	in.	
54,5	21½	10	338	26	10¼	<b>06.1524.6040</b>
63,2	25	15	507	26	10¼	<b>06.1529.6040</b>

Zubehör / accessory:

Heizelement Coffee Urn / heating element 19.9999.9879

Brennstoffdose / solid alcohol 60.3002.0690

Inhalt cap.  
Ltr. oz.  
je Dose 0,2 each tin 7

Brennstoffhalter Coffee Urn / burner holder coffee urn 06.1520.6039

Höhe	height	Ø	Ø
cm	in.	cm	in.
12,8	5	17	6¾



**Brennstoffhalter Coffee Urn  
CHANGE**

burner holder coffee urn  
porte brûleur coffee urns  
soporte quemador urna de café  
fornello coffee urn

passend zu Coffee Urns 10 und 15 l CHANGE /  
fitting for coffee urns 10 and 15 l CHANGE

Cromargan® / stainless 18/10

Höhe	height	Ø	Ø
cm	in.	cm	in.
12,8	5	17	6 <sup>3</sup> / <sub>4</sub>

06.1520.6039

**Heizelement Coffee Urn**

heating element  
plaque électrique  
placa calentadora  
piastra riscaldante

passend zu Coffee Urns 10 und 15 l CHANGE, 110 - 265 V, 150 W,  
selbstregelnd /  
fitting for coffee urns 10 and 15 l CHANGE, 110 - 265 V, 150 W, self-  
regulating



19.9999.9879



**Schild mit Kette**

name plate with chain  
étiquette avec chaîne  
etiqueta con cadena  
targhetta con aggancio a catenella

passend für Coffee Urns, individuelle Kennzeichnung möglich. Preis auf  
Anfrage. /  
fitting on Coffee Urns, individual engraving possible. Please ask for  
respective costs.

Cromargan® / stainless 18/10

Länge	length
cm	in.
63	24 <sup>3</sup> / <sub>4</sub>

06.3151.6040



# Cerealien Dispenser

## CHANGE

cereal dispenser

## CHANGE

... flaking it easy!



**Produktvarianten**  
range of products



CEREALIEN / CEREAL DISPENSER  
Reihenlösung / in-line



CEREALIEN / CEREAL DISPENSER  
rund, drehbar / round, rotatable



## Produktvorteile

**Hygienisch** - Die Behälter sind leicht zu entnehmen, nachzufüllen und komplett spülmaschinengeeignet.

**Einfach** - Die portionierte Entnahme der Cerealien durch Drehen des Bedienknopfes erklärt sich dem Gast von selbst.

**Kompakt** - Die kompakte Bauweise spart viel vom sowieso knapp bemessenen Platz auf jedem Buffet.

**Schön** - Das CHANGE-Konzept von WMF Hotel ist ein optisch gelungener Blickfang für jedes Buffet.

### Material und Verarbeitung

Das hochwertige Cromargan® ist je nach Modell mattiert oder poliert und teilweise um vergoldete Zierelemente ergänzt.

Die Cerealien-Röhre besteht aus transparentem PMMA, alle anderen Kunststoffteile aus schwarzem POM. Beide Kunststoffe sind absolut geruchsneutral und lebensmittelgeeignet.

**Platzsparend** - Die runde, drehbare Variante ist besonders schmal.

## Advantages of the products

**Hygienic** - The reservoirs are easy to remove, easy to refill and fully dishwasher safe.

**Straightforward** - Diners will find portioned dispensing of cereals by turning the knob self-explanatory.

**Compact** - The compact construction saves lots of precious space on any buffet.

**Good-looking** - The WMF Hotel's CHANGE concept is aesthetically pleasing for any buffet.

### Material and finish -

The high-grade Cromargan® is either satin finished or polished, according to the model. Some models are decorated with gold plate.

The cereal chutes are made from clear PMMA. All other plastic parts are black POM. Both plastics are totally odourless and food safe.

**Space-saving** - The rotatable round version is very slim.





### Cerealiendispenser, drehbar „Basic“ CHANGE

cereal dispenser, rotatable, „Basic“  
 dispenseur de céréales, rotatif, „Basic“  
 dispensador de cereales, rotativo, „Basic“  
 dispenser cereali, girabile, „Basic“

mit 3 Behältern, drehbar, portionierte und hygienische Entnahme durch Drehen, leicht zu befüllen, spülmaschinengeeignet, Durchmesser Behälter 11,3 cm; Inhalt jeweils 3,5 l; Unterstellhöhe 9,5 cm /  
 with 3 containers, turnable, hygienic portioning by turning, easy to refill, dishwasher safe, dia. container 4 1/2 in.; cap. each container 118,3 oz.; clear height 3 3/4 in.

Gestell Cromargan®, Behälter PMMA farblos /  
 stand stainless 18/10, container PMMA clear

Höhe	height	Ø	Ø
cm	in.	cm	in.
59,7	23 1/2	35,7	14

06.3530.6040



### Cerealiendispenser, Reihenlösung „Basic“ CHANGE

cereal dispenser, in-line „Basic“  
 dispenseur de céréales, in-line „Basic“  
 dispensador de cereales, in-line „Basic“  
 dispenser cereali, in-line „Basic“

mit 3 Behältern, portionierte und hygienische Entnahme durch Drehen, leicht zu befüllen, spülmaschinengeeignet, Durchmesser Behälter 11,3 cm; Inhalt jeweils 3,5 l; Unterstellhöhe 9,5 cm /  
 with 3 containers, hygienic portioning by turning, easy to refill, dishwasher safe, dia. container 4 1/2 in.; cap. each container 118,3 oz.; clear height 3 3/4 in.

Gestell Cromargan®, Behälter PMMA farblos /  
 stand stainless 18/10, container PMMA clear

Größe	size
cm	in.
39 x 25 x 59,7	15 1/4 x 9 3/4 x 23 1/2

06.3640.6040





### Cerealiendispenser, Reihenlösung „Manhattan“ CHANGE

cereal dispenser, in-line „Manhattan“  
 dispenseur de céréales, in-line „Manhattan“  
 dispensador de cereales, in-line „Manhattan“  
 dispenser cereali, in-line „Manhattan“

mit 3 Behältern, portionierte und hygienische Entnahme durch Drehen, leicht zu befüllen, spülmaschinengeeignet, Durchmesser Behälter 11,3 cm; Inhalt jeweils 3,5 l; Unterstellhöhe 9,5 cm /  
 with 3 containers, hygienic portioning by turning, easy to refill, dishwasher safe, diam. container 4 1/2 in.; cap. each container 118,3 oz.; clear height 3 3/4 in.

Gestell Cromargan®, Behälter PMMA farblos /  
 stand stainless 18/10, container PMMA clear

Größe	size
cm	in.
39 x 25 x 59,6	15 1/4 x 9 3/4 x 23 1/2

06.3645.6040



### Wandhalterung Cer.disp., einfach

wall mount for cer. disp., single  
 simple fixation murale pour disp. à céréales  
 sujeción sencilla de pared para disp. cereales  
 supporto per dispenser cereali

einfache Montage an der Wand, für eine Dispenser-Röhre, inkl. Schrauben und Dübel /  
 easy to fix at the wall, for 1 dispenser pipe, incl. screws and screw anchors

Cromargan® / stainless 18/10

Größe	size
cm	in.
12,5 x 13,2 x 3,9	5 x 5 1/4 x 1 1/2

55.0057.6040

Zubehör / accessory:

Cerealienbehälter / container cereal dispenser

06.3530.6041



### Wandhalterung Cer.disp., doppelt

wall mount for cer. disp., double  
 double fixation murale p. disp. à céréales  
 sujeción doble de pared para disp. Cereales  
 supporto per dispenser cereali dop.

einfache Montage an der Wand, für 2 Dispenser-Röhren, inkl.  
 Schrauben und Dübel /  
 easy to fix at the wall, for 2 dispenser pipes, incl. screws and screw  
 anchors

Cromargan® / stainless 18/10

Größe	size
cm	in.
25 x 13,2 x 3,9	9 <sup>3</sup> / <sub>4</sub> x 5 <sup>1</sup> / <sub>4</sub> x 1 <sup>1</sup> / <sub>2</sub>

**55.0056.6040**

Zubehör / accessory:

Cerealienbehälter / container cereal dispenser

06.3530.6041



# Saft- und Milchdispenser CHANGE

## Juice- and Milk Dispenser CHANGE



### Saft- und Milchdispenser »CHANGE«

#### **Einfach schön**

Alles, was auf den Tisch Ihres Buffets kommt, sollte einen einheitlichen Stil repräsentieren: Ihren. Die breite Palette der „Change“-Dispenser bietet für jedes Ambiente und jeden Geschmack das passende Modell. Das Design von WMF signalisiert Ihrem Gast »hier wird Wert auf das Detail gelegt«.

#### **Einfach erfrischend**

Das Prinzip ist simpel und effektiv: Die Edelstahl-Eisröhre wird mit Crash Ice befüllt und in die komplette Flüssigkeit getaucht. Die Kühlung erfolgt also nicht nur von unten sondern im gesamten Behälter und hält dadurch lange an.

### Juice- and Milchdispenser »CHANGE«

#### **Simply beautiful**

Everything on your buffet table should represent a consistent style: your own. The wide range of »Change« dispensers includes the right model for every environment and for every taste. The WMF design tells the customer that this is a place »where details matter«.

#### **Simply freshness**

The principle is simple and effective. The stainless steel ice tube is filled with crushed ice and lowered all the way into the liquid. That way, the product is not merely chilled from below, but all the way through, to keep it cooler longer.



## Saft- und Milchdispenser »CHANGE«

### Starke Typen

Chafing Dishes, Dispenser für Saft, Milch und Cerealien oder Coffee Urns, es passt alles zusammen.

### Einfach Qualität

Qualität und Funktionalität aus Tradition steht auch hier ganz oben.

Hochwertiges Cromargan® ist je nach Modell mattiert oder poliert und teilweise um vergoldete Zierelemente ergänzt. Der Flüssigkeitsbehälter besteht aus geruchsneutralem, hochwertigem SAN-Kunststoff, transparent bei Saft, lichtundurchlässig weiß bei Milch.

Motive für die Schilder zum downloaden, umfangreiches Zubehör und Ersatzteile finden Sie unter [www.wmf-hotel.de](http://www.wmf-hotel.de)



Stufenlos höhenverstellbar  
Step-free height adjustable



## Juice- and Milk Dispenser »CHANGE«

### Perfect match

Everything fits together: Chafing dishes, coffee urns, juice,- milk- and cereal dispensers.

### Simply quality

Quality and functionality born in tradition is our top priority.

The high-quality stainless steel is available in satin or polished finish. Some models have gold-plated decorative elements. The product container is made from odourless, high-quality SAN plastic. The juice container is clear, the milk container is opaque white.

Download-motifs for the front, extensive list of spare parts and accessories are available at [www.wmf-hotel.de](http://www.wmf-hotel.de)

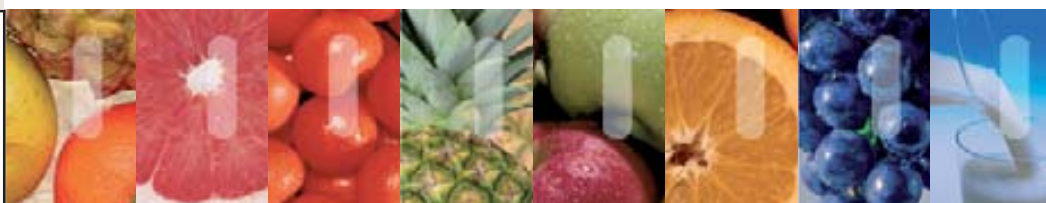



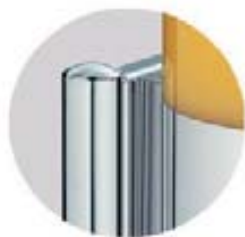

### Saftdispenser, „Basic“ CHANGE

juice dispenser, „Basic“  
dispenseur de jus, „Basic“  
dispensador de zumo, „Basic“  
dispenser per succhi di frutta, „Basic“

individuell höhenverstellbar, klare Kennzeichnung, tropffreier, hygienischer Auslauf, Kühlmöglichkeit durch Eisröhre (Zubehör). Attraktive Motive für die Frontseite zum Download unter [www.wmf-hotel.de/](http://www.wmf-hotel.de/)

individually height adjustable, clear labelling, non dripping hygienic spout, cooling with ice tube (accessory). Attractive motifs for the frontside for download at [www.wmf-hotel.de](http://www.wmf-hotel.de/)

Gestell Cromargan®, Behälter SAN-Kunststoff transparent / stand stainless 18/10, container SAN plastic clear

Mindesthöhe cm	min. height in.	Maximalhöhe cm	max. height in.	Größe cm	size in.
52	20½	60	23½	30,5 x 20	12 x 8

Inhalt mit Eisröhre Ltr.	cap. incl. ice tube oz.	Inhalt ohne Eisröhre Ltr.	cap. w/o ice tube oz.
5	175	6,5	227,5

**06.3130.6040**

Zubehör / accessory:  
Eisröhre / ice tube

06.3130.6043

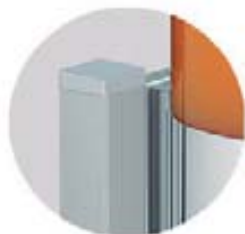

### Saftdispenser, „Manhattan“ CHANGE

juice dispenser, „Manhattan“  
dispenseur de jus, „Manhattan“  
dispensador de zumo, „Manhattan“  
dispenser per succhi di frutta, „Manhattan“

individuell höhenverstellbar, klare Kennzeichnung, tropffreier, hygienischer Auslauf, Kühlmöglichkeit durch Eisröhre (Zubehör). Attraktive Motive für die Frontseite zum Download unter [www.wmf-hotel.de/](http://www.wmf-hotel.de/)

individually height adjustable, clear labelling, non dripping hygienic spout, cooling with ice tube (accessory). Attractive motifs for the frontside for download at [www.wmf-hotel.de](http://www.wmf-hotel.de/)

Gestell Cromargan®, teilmattiert, Behälter SAN-Kunststoff transparent / stand stainless 18/10, partly satin finished, container SAN plastic clear

Mindesthöhe cm	min. height in.	Maximalhöhe cm	max. height in.	Größe cm	size in.
52	20½	60	23½	30,5 x 20	12 x 8

Inhalt mit Eisröhre Ltr.	cap. incl. ice tube oz.	Inhalt ohne Eisröhre Ltr.	cap. w/o ice tube oz.
5	175	6,5	227,5

**06.3135.6040**

Zubehör / accessory:  
Eisröhre / ice tube

06.3130.6043



### Milchdispenser, „Basic“ CHANGE

milk dispenser, „Basic“  
dispenseur de lait, „Basic“  
dispensador leche, „Basic“  
dispenser latte, „Basic“

individuell höhenverstellbar, klare Kennzeichnung, tropffreier, hygienischer Auslauf, Kühlmöglichkeit durch Eisröhre (Zubehör). Attraktive Motive für die Frontseite zum Download unter [www.wmf-hotel.de/](http://www.wmf-hotel.de/)

individually height adjustable, clear labelling, non dripping hygienic spout, cooling with ice tube (accessory). Attractive motifs for the frontside for download at [www.wmf-hotel.de](http://www.wmf-hotel.de)

Gestell Cromargan®, Behälter SAN-Kunststoff lichtundurchlässig / stand stainless 18/10, container SAN plastic opaque white

Mindesthöhe cm	min. height in.	Maximalhöhe cm	max. height in.	Größe cm	size in.
52	20½	60	23½	30,5 x 20	12 x 8

Inhalt mit Eisröhre Ltr.	cap. incl. ice tube oz.	Inhalt ohne Eisröhre Ltr.	cap. w/o ice tube oz.
5	175	6,5	227,5

**06.3390.6040**

Zubehör / accessory:  
Eisröhre / ice tube

06.3130.6043



### Milchdispenser, „Manhattan“ CHANGE

milk dispenser, „Manhattan“  
dispenseur de lait, „Manhattan“  
dispensador leche, „Manhattan“  
dispenser latte, „Manhattan“

individuell höhenverstellbar, klare Kennzeichnung, tropffreier, hygienischer Auslauf, Kühlmöglichkeit durch Eisröhre (Zubehör). Attraktive Motive für die Frontseite zum Download unter [www.wmf-hotel.de/](http://www.wmf-hotel.de/)

individually height adjustable, clear labelling, non dripping, hygienic spout, cooling with ice tube (accessory). Attractive motifs for the frontside for download at [www.wmf-hotel.de](http://www.wmf-hotel.de)

Gestell Cromargan®, teilmattiert, Behälter SAN-Kunststoff lichtundurchlässig / stand stainless 18/10, partly satin finished, container SAN plastic opaque white

Mindesthöhe cm	min. height in.	Maximalhöhe cm	max. height in.	Größe cm	size in.
52	20½	60	23½	30,5 x 20	12 x 8

Inhalt mit Eisröhre Ltr.	cap. incl. ice tube oz.	Inhalt ohne Eisröhre Ltr.	cap. w/o ice tube oz.
5	175	6,5	227,5

**06.3395.6040**

Zubehör / accessory:  
Eisröhre / ice tube

06.3130.6043

**Eisröhre**

ice tube  
tube à glace  
tubo para hielo  
tubo in acciaio

mit Crash Ice zu befüllen. Passend zu allen Saft- und Milchdispensern  
CHANGE /  
to be filled up with crash-ice. Fitting for all juice and milk dispensers  
CHANGE

Cromargan® / stainless 18/10

Höhe	height	Inhalt	cap.	Ø	Ø upper
cm	in.	Ltr.	oz.	cm	in.
27	10 <sup>3</sup> / <sub>4</sub>	1	35	7,5	35

**06.3130.6043**

**Saftbar, mit Gläserbord**

juice bar, with glass holder  
bar à jus de fruit, avec étagère pour verres  
set para zumos, con portavasos  
set girevole per succhi di frutta

bestehend aus: Gestell, 4 Kühlpellets /  
consisting of: stand, 4 cooling elements

drehbar /  
turnable

Cromargan®, Plexiglas / stainless 18/10, plexiglass

Höhe	height	Ø	Ø
cm	in.	cm	in.
47	18 <sup>1</sup> / <sub>2</sub>	47	18 <sup>1</sup> / <sub>2</sub>

**06.3232.6040**

Zubehör / accessory:

Glaskrug / glass pitcher  
Inhalt cap.  
Ltr. oz.  
1,5 52,5

60.3061.9990

Ersatzteil / spare part:

Kühlpellet / cooling element  
Ø Ø  
cm in.  
16 6<sup>1</sup>/<sub>4</sub>

19.9999.5850



# Getränkékühler DIVA Beverage Cooler DIVA

... keeping it cool!

## Getränkékühler »DIVA«

### Eleganter Blickfang

Formschön und stilvoll präsentiert sich der neue Getränkekühler DIVA von WMF auf allen Arrangements Ihres Hauses. Egal ob bei Tagungen, Buffets oder eleganten Tischensembles – DIVA setzt wirkungsvolle Akzente und bietet viel Platz für kalte Getränkeflaschen oder Karaffen.

Neben der schicken Optik verzaubert DIVA besonders mit inneren Werten: Bestehend aus zwei kombinierbaren Elementen, einem doppelwandigen Edelstahlmantel und einem vorkühlbaren Kunststoffeinsatz, hält das Designobjekt die ihm anvertrauten Getränke ganz ohne Kondenswasserbildung kalt. Perfekt für die edle Platzierung auf dem Buffet.

### Flexible Coolness

Das Kunststoff-Kühlelement ist entnehmbar, im Gefrierfach vorkühlbar und kann auch ohne Edelstahlkühler eingesetzt werden – ein flexibler Allrounder.

## Beverage Cooler »DIVA«

### Elegantly eye-catching

The new DIVA beverage cooler from WMF graces your table with style and form. Whether an event, buffet or just adding some extra class to your table, the DIVA looks great and offers optimal space for drink bottles or carafes.

Alongside the stunning looks, the DIVA also has more to offer on the inside: it is made up of two combinable elements, one is a double-wall, stainless steel sleeve that can be used together with a synthetic cooling element that ensure this work of design truly delivers condensation-free, cool drinks. Perfect for a classy arrangement at the buffet.

### Flexible Coolness

The synthetic cooling element is removable, can be cooled in the freezer compartment, and can also be used without the stainless steel cooler – a true all-rounder.



### Getränkékühler

#### DIVA

beverage cooler  
 seau à boisson  
 cubo bebida  
 rinfresca bevanda



doppelwandig und stapelbar. Kann verwendet werden mit Kühlelement 55.0125.6040, für 3 Wasser-, Saft-, Milchkaraffen 06.1770.6040, 3 Getränkeflaschen (Bsp. Wasser, Wein, etc.) mit max. 10 cm Flaschendurchmesser, 6 Getränkeflaschen (Bsp. Wasser, Saft, Bier etc.) mit max. 7 cm Flaschendurchmesser /

double wall and stackable. Can be used with cooling element 55.0125.6040, for 3 water/juice/milk decanter 06.1770.6040, 3 beverage bottles (e.g. water, wine, etc.) with max. 4 in. bottle diameter, 6 beverage bottles (e.g. water, juice, beer, etc.) with max. 2 3/4 in. bottle diameter

Cromargan® / stainless 18/10

Größe	size
cm	in.
27,5 x 26,2 x 17	10 <sup>3</sup> / <sub>4</sub> x 10 <sup>1</sup> / <sub>4</sub> x 6 <sup>3</sup> / <sub>4</sub>

55.0124.6040



### Kühlelement

#### DIVA

cooling element  
 élément réfrigérante  
 elemento refrigerador  
 elemento per il ghiaccio



mit Kühlgelfüllung zum Einfrieren. Stapelbar. Kann verwendet werden mit Getränkekühler 55.0124.6040 oder separat, für 3 Wasser-, Saft-, Milchkaraffen 06.1770.6040, 3 Getränkeflaschen (Bsp. Wasser, Wein, etc.) mit max. 10 cm Flaschendurchmesser, 6 Getränkeflaschen (Bsp. Wasser, Saft, Bier etc.) mit max. 7 cm Flaschendurchmesser / with cooling core for freezing. Stackable. Can be used with beverage cooler 55.0124.6040 or separately, for 3 water decanter 06.1770.6040, 3 beverage bottles (e.g. water, wine, etc.) with max. 4 in. bottle diameter, 6 beverage bottles (e.g. water, juice, beer, etc.) with max. 2 3/4 in. bottle diameter

Kunststoff / plastic

Größe	size
cm	in.
25,3 x 24 x 13,3	10 x 9 <sup>1</sup> / <sub>2</sub> x 5 <sup>3</sup> / <sub>4</sub>

55.0125.9990







**Cerealien-/Saft-Set**

set for cereal/juice dispenser  
 presentoir a cereales/jus de fruit  
 set para cereales/jugo  
 set per cereali/succhi

bestehend aus Gestell und 3 Schüttflöten mit Deckel, Inhalt je 2 Ltr., für Saft, Milch oder Cerealien /  
 consisting of base and 3 containers with lid, cap. 67,6 oz. each, for juice, milk or cereals

Cromargan®, SAN klar / Cromargan®, SAN clear

Größe	size	
cm	in.	
44,5 x 17,2 x 29,4	17 1/2 x 6 3/4 x 11 1/2	<b>06.3648.6040</b>

Ersatzteil / spare part:

Gestell, 3 Ausschnitte / base, for 3 inserts 06.3648.6045

Größe	size
cm	in.
44,5 x 17,2 x 3	17 1/2 x 6 3/4 x 1 1/4

Cerealien/Saft-Flöte / cereal/juice flute 06.8253.6040

Höhe	height	Inhalt	cap.	Ø	Ø
cm	in.	Ltr.	oz.	cm	in.
29,4	11 1/2	2	67,6	12,6	5



**Buffet-Set, Glas**

buffet set, glass  
 ensemble buffet, verre  
 juego de bufete, cristal  
 set per buffet, vetro

bestehend aus Gestell und 3 Gläsern (Inhalt je 0,7 Ltr.) inkl. Deckel mit Beschriftungsmöglichkeit. Beschriftungs-Beispiele zum Download auf [www.wmf-hotel.de](http://www.wmf-hotel.de) /  
 consisting of base with 3 glasses (cap. 23,66 oz. each) incl. lid. Motifs for labelling available for download on [www.wmf-hotel.de](http://www.wmf-hotel.de)

Cromargan®, Glas / stainless 18/10, glass

Größe	size	
cm	in.	
44,5 x 17,2 x 13	17 1/2 x 6 3/4 x 5	<b>06.8242.6040</b>

Ersatzteil / spare part:

Gestell, 3 Ausschnitte / base, for 3 inserts 06.3648.6045

Größe	size
cm	in.
44,5 x 17,2 x 3	17 1/2 x 6 3/4 x 1 1/4

Glasbehälter / glass bowl 60.8241.9990

Höhe	height	Inhalt	cap.	Ø	Ø
cm	in.	Ltr.	oz.	cm	in.
13	5	0,75	25,35	10,5	4 1/4

Deckel, mit Plexihülle / lid, with plexi cover 06.8241.6042

Plexihülle für Deckel / plastic holder for lid 60.8241.9996

### Buffet-Set, Porzellan

buffet set, porcelain  
ensemble buffet, porcelaine  
juego de bufete, porcelana  
set per buffet, porcellana

bestehend aus Gestell und 3 Porzellanbehältern (Inhalt je 0,65 Ltr.)  
inkl. Deckel mit Beschriftungsmöglichkeit. Beschriftungs-Beispiele zum  
Download auf [www.wmf-hotel.de](http://www.wmf-hotel.de) /  
consisting of base with 3 porcelain bowls (cap. 21,97 oz. each) incl. lid.  
Motifs for labelling available for download on [www.wmf-hotel.de](http://www.wmf-hotel.de)



Cromargan®, Porzellan / stainless 18/10, porcelain

Größe	size	
cm	in.	
44,5 x 17,2 x 13	17 <sup>1</sup> / <sub>2</sub> x 6 <sup>3</sup> / <sub>4</sub> x 5	<b>06.8257.6040</b>

Ersatzteil / spare part:

Gestell, 3 Ausschnitte / base, for 3 inserts 06.3648.6045

Größe	size
cm	in.
44,5 x 17,2 x 3	17 <sup>1</sup> / <sub>2</sub> x 6 <sup>3</sup> / <sub>4</sub> x 1 <sup>1</sup> / <sub>4</sub>

Porzellanbehälter / porcelain bowl 60.8258.9990

Höhe	height	Inhalt	cap.	Ø	Ø
cm	in.	Ltr.	oz.	cm	in.
13	5	0,65	21,97	10,5	4 <sup>1</sup> / <sub>4</sub>

Deckel, mit Plexihülle / lid, with plexi cover 06.8241.6042

Plexihülle für Deckel / plastic holder for lid 60.8241.9996



### Teller-/Schalengestell

plate and bowl stand  
support pour bols à céréales  
soporte para platos o fuentes  
supporto per piatti e coppe

ohne Glasschalen /  
without glass bowls

Cromargan® / stainless 18/10

Höhe	height	Ø Ring	Ø ring
cm	in.	cm	in.
40,4	16	19,5	7 <sup>3</sup> / <sub>4</sub>

**06.4394.6040**

Zubehör / accessory:

Glasschale, 20 cm / glass bowl, 20 cm 19.9999.8642

### Dessertgestell

dessert stand  
présentoir à gâteau  
soporte plato postre  
porta piattini per dessert

ohne Gläser /  
w/o glasses

Cromargan® / stainless 18/10

Größe	size	
cm	in.	
40,6 x 7 x 4,9	16 x 2 <sup>3</sup> / <sub>4</sub> x 2	<b>06.8230.6040</b>

Zubehör / accessory:

Glas S (VPE 6 Stk.) / glass S (unit 6 pcs.) 60.2506.9990



**Dessertgestell  
PURE EXCLUSIV**

dessert stand  
présentoir à gâteau  
soporte plato postre  
porta piattini per dessert

in 2 Holzvarianten. Mit 3 Einsätzen für wahlweise Gläser S, Tassen S oder Sahnekännchen (o. Abb.) von KaffeeKultur und Tassen S von CultureCup (o. Abb.). Nicht spülmaschinengeeignet! (ohne Gläser) / in 2 wood versions. With 3 inserts alternatively for glasses S, cups S or creamer (w/o pic.) of CoffeeCulture and cups S CultureCup (w/o pic.). Not dishwasher-safe! (w/o glasses)

Cromargan®, Holz dunkel gebeizt, Holz lackiert / stainless 18/10, wood dark stained, wood lacquered

Menage klein dunkel / stand small dark

Größe	size	
cm	in.	
20,5 x 6,2 x 3,7	8 x 2 <sup>1</sup> / <sub>2</sub> x 1 <sup>1</sup> / <sub>2</sub>	<b>55.0039.6040</b>

Menage klein natur / stand small nature

Größe	size	
cm	in.	
20,5 x 6,2 x 3,7	8 x 2 <sup>1</sup> / <sub>2</sub> x 1 <sup>1</sup> / <sub>2</sub>	<b>55.0039.6140</b>

Glas S (VPE 6 Stk.) / glass S (unit 6 pcs.)

Höhe	height	Inhalt	cap.	
cm	in.	Ltr.	oz.	
7,4	3	0,1	3,4	<b>60.2506.9990</b>

\* Artikel einzeln bestellen / please order articles separately



**Dessertgestell  
PURE EXCLUSIV**

dessert stand  
présentoir à gâteau  
soporte plato postre  
porta piattini per dessert

in 2 Holzvarianten. Mit 3 Einsätzen für wahlweise Gläser S, Tassen S (o. Abb.) oder Sahnekännchen von KaffeeKultur und Tassen S von CultureCup (o. Abb.). Nicht spülmaschinengeeignet! / in 2 wood versions. With 3 inserts alternatively for glasses S, cups S (w/o pic.) or creamer of CoffeeCulture and cups S of CultureCup (w/o pic.). Not dishwasher-safe!

Cromargan®, Holz dunkel gebeizt, Holz lackiert / stainless 18/10, wood dark stained, wood lacquered

Menage klein dunkel / stand small dark

Größe	size	
cm	in.	
20,5 x 6,2 x 3,7	8 x 2 <sup>1</sup> / <sub>2</sub> x 1 <sup>1</sup> / <sub>2</sub>	<b>55.0039.6040</b>

Menage klein natur / stand small nature

Größe	size	
cm	in.	
20,5 x 6,2 x 3,7	8 x 2 <sup>1</sup> / <sub>2</sub> x 1 <sup>1</sup> / <sub>2</sub>	<b>55.0039.6140</b>

Sahnekännchen (VPE 6 Stk.) / creamer (unit 6 pcs.)

Höhe	height	Inhalt	cap.	
cm	in.	Ltr.	oz.	
7	2 <sup>3</sup> / <sub>4</sub>	0,1	3,4	<b>55.0033.9990</b>

Deckel mit Ausschnitt / lid with cut-out **55.0031.6040**

Espresso-/Mokkalöffel / demi-tasse spoon **54.9901.6040**

\* Artikel einzeln bestellen / please order articles separately





### Dessertgestell

dessert stand  
présentoir à gâteau  
soporte platos postre  
porta piattini per dessert

passend für Teller bis Ø 16 cm (ohne Teller) /  
fitting for plates Ø 6<sup>1</sup>/<sub>4</sub> in. (without plates)

Cromargan® / stainless 18/10

Höhe	height	Ø	Ø	Ø Ring	Ø ring
cm	in.	cm	in.	cm	in.
25,5	10	18,5	7 <sup>1</sup> / <sub>4</sub>	10,5	4 <sup>1</sup> / <sub>4</sub>

06.4397.6040



### Serviergestell

serving stand  
présentoir à assiette  
soporte platos  
portapiatti

passend für Teller Ø 26 cm (ohne Teller) /  
fitting for plates Ø 10<sup>1</sup>/<sub>4</sub> in. (without plates)

Cromargan® / stainless 18/10

Höhe	height	Ø	Ø	Ø Ring	Ø ring
cm	in.	cm	in.	cm	in.
40	15 <sup>3</sup> / <sub>4</sub>	28,5	11 <sup>1</sup> / <sub>4</sub>	18,6	7 <sup>1</sup> / <sub>4</sub>

06.4395.6040



### Etagère, 3-teilig PURE

etagere, 3 parts  
étagère, en 3 parties  
frutero, de 3 pisos  
porta frutta, 3 piani

Cromargan® / stainless 18/10

Höhe	height	Ø Schale	Ø bowl
cm	in.	cm	in.
52,5	20 <sup>3</sup> / <sub>4</sub>	46 / 37 / 28	18 / 14 <sup>1</sup> / <sub>2</sub> / 11

06.0470.6040



### Mokkaétagère, 3-teilig

#### PURE

pastry stand, 3 parts  
 porte petits fours, en 3 parties  
 portapastas, de 3 pisos  
 alzata portadolci, 3 piani

Cromargan® / stainless 18/10

Höhe	height	Ø Schale	Ø bowl
cm	in.	cm	in.
22,5	8 <sup>3</sup> / <sub>4</sub>	9 / 14 / 20	3 <sup>1</sup> / <sub>2</sub> / 5 <sup>1</sup> / <sub>2</sub> / 8

**06.6903.6040**



### Etagère, 3-teilig

#### BISTRO

etagere, 3 parts  
 étagère, en 3 parties  
 frutero, de 3 pisos  
 porta frutta, 3 piani

Cromargan®, Glas / stainless 18/10, glass

Höhe	height	Ø Schale	Ø bowl
cm	in.	cm	in.
56	22	30 / 38 / 50	11 <sup>3</sup> / <sub>4</sub> / 15 / 19 <sup>3</sup> / <sub>4</sub>

**06.6893.6040**

Ersatzteil / spare part:

Glasschale klein / glass plate small	19.9999.8643
Glasschale mittel / glass plate medium	19.9999.8644
Glasschale groß / glass plate large	19.9999.8645



### Etagère

etagere  
étagère  
frutero articulado  
porta frutta

ohne Einsätze, Arme drehbar /  
without inserts, insert holders turnable

rostfrei / stainless steel

Höhe	height	Ringe
cm	in.	psc.
51	20	4tlg.
70	27½	6tlg.

06.3010.6040

06.3011.6040



### Glasschale, 20 cm

glass bowl, 20 cm  
coupe verre glasskin, 20 cm  
depósitos de cristal, 20 cm  
interno in vetro, 20 cm

passend in Etagère 06.3010.6040, 06.3011.6040, 06.4394.6040,  
06.2441.6040 combiNation buffet /  
fitting in etagere 06.3010.6040, 06.3011.6040, 06.4394.6040,  
06.2441.6040 combiNation buffet

Höhe	height	Ø	Ø
cm	in.	cm	in.
8,5	3¼	20	8

19.9999.8642



### Tablett, rund

service tray, round  
plateau de service, rond  
bandeja, redonda  
vassoio, rotondo

passend in Etagère 06.3010.6040, 06.3011.6040, 06.2441.6040  
combiNation buffet /  
fitting in etagere 06.3010.6040, 06.3011.6040, 06.2441.6040  
combiNation buffet

Cromargan® / stainless 18/10

Ø außen	outer Ø	Ø innen	Ø inside
cm	in.	cm	in.
29,5	11½	24,5	9¾

06.3014.6041





**Kühlbehälter, mit Kühlpellet**

cooler, with cooling element  
 coupe réfrigérante, avec élément réfrigérante  
 recipiente, con acumulador de frio  
 base, con elemento refrigerante

passend in Etagère 06.3010.6040, 06.3011.6040, 06.2441.6040  
 combiNation buffet zum Kühlen von Tablett 06.3014.6041 /  
 fitting in etagere 06.3010.6040, 06.3011.6040, 06.2441.6040  
 combiNation buffet to cool tray 06.3014.6041

Cromargan® / stainless 18/10

Ø	Ø
cm	in.
19	7½

**06.3014.6044**

Ersatzteil / spare part:

Kühlpellet / cooling element

19.9999.5850



**Früchtekorb**

fruit basket  
 panier à fruits  
 frutero  
 fruttiera

passend in Etagère 06.3010.6040, 06.3011.6040, 06.2441.6040  
 combiNation buffet nur in Verbindung mit Kühlbehälter 06.3014.6045  
 (bitte separat bestellen) /  
 fitting together with cooler 06.3014.6045 (please order separately) in  
 etagere 06.3010.6040, 06.3011.6040, 06.2441.6040 combiNation buffet

Cromargan® / stainless 18/10

Höhe	height	Ø	Ø
cm	in.	cm	in.
22,5	8¾	26	10¼

**06.6521.6040**



**Plattenständer niedrig, GN 1/1**

tray stand low, GN 1/1  
 support pour plaques bas, GN 1/1  
 soporte platos bajo, GN 1/1  
 supporto piatto basso, GN 1/1

kombinierbar mit Servierplatten GN 1/1 06.2431.9990 (CORIAN), 06.7660.6040 (Edelstahl), 60.3053.9990 (Porzellan), 06.2432.9990 (Kunststoff), Kühlakku GN 1/2 und Abdeckhauben 06.2937.6040, 55.0134.6040 /  
 combinable with serving plates GN 1/1 06.2431.9990 (CORIAN), 06.7660.6040 (stainless steel 18/10), 60.3053.9990 (Porcelain), 06.2432.9990 (Plastic), cooling block GN 1/2 and covers 06.2937.6040, 55.0134.6040

stapelbar /  
 stackable

Cromargan® / stainless 18/10

Größe	size
cm	in.
51 x 30 x 12	20 <sup>1</sup> / <sub>8</sub> x 11 <sup>3</sup> / <sub>4</sub> x 4 <sup>3</sup> / <sub>4</sub>

55.0132.6040



**Plattenständer hoch, GN 1/1**

tray stand high, GN 1/1  
 support pour plaques haut, GN 1/1  
 soporte platos alto, GN 1/1  
 supporto piatto alto, GN 1/1

kombinierbar mit Servierplatten GN 1/1 06.2431.9990 (CORIAN), 06.7660.6040 (Edelstahl), 60.3053.9990 (Porzellan), 06.2432.9990 (Kunststoff), Kühlakku GN 1/2 und Abdeckhauben 06.2937.6040, 55.0134.6040 /  
 combinable with serving plates GN 1/1 06.2431.9990 (CORIAN), 06.7660.6040 (stainless steel 18/10), 60.3053.9990 (Porcelain), 06.2432.9990 (Plastic), cooling block GN 1/2 and covers 06.2937.6040, 55.0134.6040

stapelbar /  
 stackable

Cromargan® / stainless 18/10

Größe	size
cm	in.
51 x 30 x 18	20 <sup>1</sup> / <sub>8</sub> x 11 <sup>3</sup> / <sub>4</sub> x 7 <sup>1</sup> / <sub>8</sub>

55.0133.6040



**Kühlakku, GN 1/2**

cooling block, GN 1/2  
 brigue réfrigérante, GN 1/2  
 acumulador refrigerador, GN 1/2  
 tavoletta per il ghiaccio, GN 1/2

2 Stück für Plattenständer GN 1/1 /  
 2 pcs. for trays stands GN 1/1

Kunststoff mit Kühlflüssigkeit / plastic with cooling liquid

Kühlakku, Gastronorm 1/2 /  
 cooling block, Gastronorm 1/2

Größe	size
cm	in.
25,5 x 20,3 x 3,2	10 x 8 x 1 <sup>1</sup> / <sub>4</sub>

60.3065.9990





**Platten, GN 1/1**

platters, GN 1/1  
 planche pour recipient, GN 1/1  
 fuente, GN 1/1  
 piatto, GN 1/1

passend auf Plattenständer hoch und niedrig und alle GN 1/1 Rahmen /  
 fitting on tray stand high and low and all GN 1/1 frames

	Größe cm	size in.	
CORIAN®	53 x 32,5	20 <sup>3</sup> / <sub>4</sub> x 12 <sup>3</sup> / <sub>4</sub>	06.2431.9990
Cromargan® / stainless 18/10	53 x 32,5	20 <sup>3</sup> / <sub>4</sub> x 12 <sup>3</sup> / <sub>4</sub>	06.7660.6040
Porzellan / porcelain	2 x 53 x 32,5	3/4 x 20 <sup>3</sup> / <sub>4</sub> x 12 <sup>3</sup> / <sub>4</sub>	60.3053.9990
Kunststoff / plastic	53 x 32,5	20 <sup>3</sup> / <sub>4</sub> x 12 <sup>3</sup> / <sub>4</sub>	06.2432.9990



**Abdeckhaube**

cover for trays  
 cloche pour plateaux  
 campana para bandejas  
 coperchio adatto per vassoio

mit 2 seitlichen Eingriffen, passend für Tablett GN 1/1 ohne Griffe und  
 Plattenständer niedrig/hoch /  
 with two side openings, fitting for trays GN 1/1 without handles and on  
 tray stands low/high

Kunststoff glasklar, Griff verchromt /  
 high quality plastic, handle chrome plated

Größe cm	size in.	
55,5 x 35 x 14,5	21 <sup>3</sup> / <sub>4</sub> x 13 <sup>3</sup> / <sub>4</sub> x 5 <sup>3</sup> / <sub>4</sub>	06.2937.6040



**Abdeckhaube**

cover for trays  
 cloche pour plateaux  
 campana para bandejas  
 coperchio adatto per vassoio

halbrollend, passend für Platten GN 1/1 ohne Griffe und Plattenständer  
 niedrig/hoch /  
 half rolling, fitting for plates GN 1/1 without handles and tray stands  
 low/high

Kunststoff glasklar, Griff verchromt /  
 high quality plastic, handle chrome plated

Größe cm	size in.	
53 x 32,5 x 17	20 <sup>3</sup> / <sub>4</sub> x 12 <sup>3</sup> / <sub>4</sub> x 6 <sup>3</sup> / <sub>4</sub>	55.0134.9990



**Tablett, rund  
CLASSIC**

serving tray, round  
plateau de service, rond  
bandeja, redonda  
vassoio, rotondo

Ø	Ø
cm	in.
29,5	11 1/2
35	13 3/4
41,7	16 1/2

Cromargan®	versilbert
stainless 18/10	silverplated
<b>06.7260.6040</b>	<b>19.7260.6440</b>
<b>06.7261.6040</b>	<b>19.7261.6440</b>
<b>06.7262.6040</b>	<b>19.7262.6440</b>



**Tablett, rund  
BISTRO**

serving tray, round  
plateau de service, rond  
bandeja, redonda  
vassoio, rotondo

stapelbar /  
stackable

Cromargan® / stainless 18/10

Ø	Ø
cm	in.
42,6	16 3/4

**06.7679.6040**



**Tablett, oval**

serving tray, oval  
plateau de service, ovale  
bandeja, oval  
vassoio, ovale

Cromargan® / stainless 18/10

Größe	size
cm	in.
51,6 x 39,3	20 1/4 x 15 1/2

**06.7265.6040**



**Kaffeetablett  
PURE**

serving tray  
plateau de service  
bandeja  
vassoio

stapelbar, oval /  
stackable, oval

Cromargan® / stainless 18/10

Größe	size
cm	in.
27 x 17	10 1/2 x 6 3/4

**06.7550.6040**



**Tablett, oval**

**PURE**

serving tray, oval  
 plateau de service, ovale  
 bandeja, oval  
 vassoio, ovale

passend für Toastständer 06.4280.6040 und Porzellanschale 3geteilt 60.3538.9990 /  
 suitable for toast rack 06.4280.6040 and for porcelain bowl 3pcs. 60.3538.9990

stapelbar /  
 stackable

Cromargan® / stainless 18/10

Größe	size
cm	in.
24,5 x 12	9 <sup>1</sup> / <sub>2</sub> x 4 <sup>3</sup> / <sub>4</sub>

**06.7551.6040**



**Tablett**  
**URBAN**

tray  
 plateau  
 bandeja  
 vassoio

Cromargan® / stainless 18/10

Größe	size
cm	in.
23 x 10,7	8 x 4 <sup>1</sup> / <sub>4</sub>

**55.0058.6045**



**Tablett, oval**

serving tray, oval  
 plateau de service, ovale  
 bandeja, oval  
 vassoio, ovale

Größe	size
cm	in.
22 x 15,5	8 <sup>3</sup> / <sub>4</sub> x 6
27 x 20	10 <sup>1</sup> / <sub>2</sub> x 8
29 x 22,5	11 <sup>1</sup> / <sub>2</sub> x 8 <sup>3</sup> / <sub>4</sub>

Cromargan®	versilbert
stainless 18/10	silverplated
<b>06.7540.6040</b>	<b>19.7540.6440</b>
<b>06.7542.6040</b>	<b>19.7542.6440</b>
<b>06.7543.6040</b>	<b>19.7543.6440</b>



**Tablett, oval  
CLASSIC**

serving tray, oval  
plateau de service, ovale  
bandeja, oval  
vassoio, ovale

Cromargan® / stainless 18/10

Größe	size
cm	in.
59,5 x 46,7	23 <sup>1</sup> / <sub>2</sub> x 18 <sup>1</sup> / <sub>2</sub>

06.7836.6040\*

\* Maße ohne Griffe / measures without handles



**Tablett, oval  
BISTRO**

serving tray, oval  
plateau de service, ovale  
bandeja, oval  
vassoio, ovale

stapelbar /  
stackable

Cromargan® / stainless 18/10

Größe	size
cm	in.
51,6 x 39	20 <sup>1</sup> / <sub>4</sub> x 15 <sup>1</sup> / <sub>4</sub>

06.7681.6040



**Tablett, Gastronorm,  
CLASSIC**

serving tray, Gastronorm  
plateau de service, Gastronorm  
bandeja, Gastronorm  
vassoio, Gastronorm

Passend auf alle GN <sup>1</sup>/<sub>1</sub> Rahmen von combiNation buffet /  
fitting on all GN <sup>1</sup>/<sub>1</sub> frames of combiNation buffet

GN <sup>1</sup>/<sub>1</sub>, rechteckig /  
GN <sup>1</sup>/<sub>1</sub>, rectangular

Größe	size
cm	in.
53 x 32,5	20 <sup>3</sup> / <sub>4</sub> x 12 <sup>3</sup> / <sub>4</sub>

Cromargan®	versilbert
stainless 18/10	silverplated
<b>06.7849.6040</b>	<b>19.7849.6440</b>



**Tablett Gastronorm  
CLASSIC**

serving tray Gastronorm  
plateau de service Gastronorm  
bandeja Gastronorm  
vassoio Gastronorm

rechteckig /  
rectangular

Cromargan® / stainless 18/10

	Größe	size
	cm	in.
GN <sup>1</sup> / <sub>1</sub>	53 x 32,5	20 <sup>3</sup> / <sub>4</sub> x 12 <sup>3</sup> / <sub>4</sub>
GN <sup>2</sup> / <sub>1</sub>	65 x 53	25 <sup>1</sup> / <sub>2</sub> x 20 <sup>3</sup> / <sub>4</sub>

06.7838.6040

06.7839.6040

Maße ohne Griffe / measures without handles





**Tablett, Gastronorm**

serving tray, Gastronorm  
 plateau de service, Gastronorm  
 bandeja, Gastronorm  
 vassoio, Gastronorm

rechteckig /  
 rectangular

Cromargan® / stainless 18/10

	Größe cm	size in.	
GN 1/2*	32,5 x 26,5	12 <sup>3</sup> / <sub>4</sub> x 10 <sup>1</sup> / <sub>2</sub>	<b>06.7658.6040</b>
GN 1/1**	53 x 32,5	20 <sup>3</sup> / <sub>4</sub> x 12 <sup>3</sup> / <sub>4</sub>	<b>06.7660.6040</b>
GN 2/1	65 x 53	25 <sup>1</sup> / <sub>2</sub> x 20 <sup>3</sup> / <sub>4</sub>	<b>06.7661.6040</b>

\* Passend auf alle GN 1/2 Rahmen / fitting on all GN 1/2 frames

\*\* Passend auf alle GN 1/1 Rahmen und auf Plattenständer niedrig/hoch /  
 fitting on all GN 1/1 frames and on tray stands low/high



**Tablett Gastronorm  
 BISTRO**

serving tray Gastronorm  
 plateau de service Gastronorm  
 bandeja Gastronorm  
 vassoio Gastronorm

GN 1/1, stapelbar, rechteckig /  
 GN 1/1, stackable, rectangular

Cromargan® / stainless 18/10

Größe cm	size in.	
53 x 32,5	20 <sup>3</sup> / <sub>4</sub> x 12 <sup>3</sup> / <sub>4</sub>	<b>06.7680.6040</b>



**Tablett Gastronorm  
 NEUTRAL**

serving tray Gastronorm  
 plateau de service Gastronorm  
 bandeja Gastronorm  
 vassoio Gastronorm

rechteckig /  
 rectangular

Cromargan® / stainless 18/10

Größe cm	size in.	
GN 1/1	53 x 32,5	20 <sup>3</sup> / <sub>4</sub> x 12 <sup>3</sup> / <sub>4</sub>
GN 2/1	65 x 53	25 <sup>1</sup> / <sub>2</sub> x 20 <sup>3</sup> / <sub>4</sub>

Maße ohne Griffe / measures without handles



### Tablett, rechteckig, Gastronorm

serving tray, rectangular, Gastronorm  
 plateau de service, rectangulaire, Gastronorm  
 bandeja, rectangular, Gastronorm  
 vassoio, rettangolare, Gastronorm

Passend auf alle GN 1/1 Rahmen von combiNation buffet /  
 fitting on all GN 1/1 frames of combiNation buffet

GN 1/1, stapelbar, rechteckig, schnittfest, spülmaschinenfest /  
 GN 1/1, stackable, rectangular, resistant against cutting, dishwasher-safe

Kunststoff, Cromargan® - Griffe /  
 high quality plastic, handle stainless 18/10

Größe	size
cm	in.
53 x 32,5	20 <sup>3</sup> / <sub>4</sub> x 12 <sup>3</sup> / <sub>4</sub>

06.7683.6040



### Tablett, rechteckig

serving tray, rectangular  
 plateau de service, rectangulaire  
 bandeja, rectangular  
 vassoio, rettangolare

Cromargan® / stainless 18/10

Größe	size
cm	in.
40,1 x 29	15 <sup>3</sup> / <sub>4</sub> x 11 <sup>1</sup> / <sub>2</sub>
52,6 x 40,8	20 <sup>3</sup> / <sub>4</sub> x 16

06.7269.6040

06.7271.6040



### Tablett, rechteckig

serving tray, rectangular  
 plateau de service, rectangulaire  
 bandeja, rectangular  
 vassoio, rettangolare

Cromargan® / stainless 18/10

Größe	size
cm	in.
28,5 x 21	11 <sup>1</sup> / <sub>4</sub> x 8 <sup>1</sup> / <sub>4</sub>
33 x 26	13 x 10 <sup>1</sup> / <sub>4</sub>
42,5 x 31,5	16 <sup>3</sup> / <sub>4</sub> x 12 <sup>1</sup> / <sub>2</sub>

06.7585.6040

06.7586.6040

06.7588.6040



### Tablett, rechteckig CLASSIC

serving tray, rectangular  
 plateau de service, rectangulaire  
 bandeja, rectangular  
 vassoio, rettangolare

Cromargan® / stainless 18/10

Größe	size
cm	in.
77,2 x 50,7	30 <sup>1</sup> / <sub>2</sub> x 20

06.7842.6040

Maße ohne Griffe / measures without handles



**Tablett, rechteckig  
NEUTRAL**

serving tray, rectangular  
plateau de service, rectangulaire  
bandeja, rectangular  
vassoio, rettangolare

Cromargan® / stainless 18/10

Größe	size
cm	in.
52,6 x 40,8	20 <sup>3</sup> / <sub>4</sub> x 16

06.8444.6040

Maße ohne Griffe / measures without handles



**Käseglocke  
NEUTRAL**

cheese dish  
cloche à fromage  
quesera  
porta formaggio

Holzeinsatz Buche / beech wooden insert

	Ø	Ø	
	cm	in.	
passt in Tablett 7262 / fitting tray 7262	36,7	14 <sup>1</sup> / <sub>2</sub>	60.3103.9990

Plexiglashaube / plastic cover

	Ø	Ø	
	cm	in.	
passt zu Einsatz 3103 / fitting insert 3103	34	13 <sup>1</sup> / <sub>2</sub>	06.2864.6040



**Abdeckhaube**

cover for trays  
cloche pour plateaux  
campana para bandejas  
coperchio adatto per vassoio

mit 2 seitlichen Eingriffen, passend für Tablett GN 1/1 ohne Griffe und Plattenständer niedrig/hoch /  
with two side openings, fitting for trays GN 1/1 without handles and on tray stands low/high

Kunststoff glasklar, Griff verchromt /  
high quality plastic, handle chrome plated

Größe	size
cm	in.
55,5 x 35 x 14,5	21 <sup>3</sup> / <sub>4</sub> x 13 <sup>3</sup> / <sub>4</sub> x 5 <sup>3</sup> / <sub>4</sub>

06.2937.6040



**Kuchen-/Tortenplatte**

cake plate  
plat à tarte  
plato tarta  
piatto da torta

Cromargan® / stainless 18/10

Höhe	height	Ø	Ø
cm	in.	cm	in.
14,5	5 <sup>3</sup> / <sub>4</sub>	36	14 <sup>1</sup> / <sub>4</sub>

06.4274.6040

**Früchtekorb**

fruit basket  
panier à fruits  
frutero  
fruttiera

passend in Etagère 06.3010.6040, 06.3011.6040, 06.2441.6040  
combiNation buffet nur in Verbindung mit Kühlbehälter 06.3014.6045  
(bitte separat bestellen) /  
fitting together with cooler 06.3014.6045 (please order separately) in  
etagere 06.3010.6040, 06.3011.6040, 06.2441.6040 combiNation buffet

Cromargan® / stainless 18/10

Höhe	height	Ø	Ø
cm	in.	cm	in.
22,5	8 <sup>3</sup> / <sub>4</sub>	26	10 <sup>1</sup> / <sub>4</sub>

06.6521.6040

**Brotkorb, rund  
OLE PALSBY**

bread-basket, round  
panier à pain, rond  
cesta del pan, redonda  
cestino per il pane, rotondo

Cromargan® / stainless 18/10

Ø	Ø
cm	in.
18	7 <sup>1</sup> / <sub>2</sub>
21	8 <sup>1</sup> / <sub>4</sub>
26	10 <sup>1</sup> / <sub>4</sub>

06.6575.6040

06.6513.6040

06.6514.6040

**Brotkorb  
PURE**

bowl for bread  
panier à pain  
panera  
portapane

stapelbar /  
stackable

Cromargan® teilmattiert / stainless 18/10 partly satin finished

Größe	size
cm	in.
25 x 14 x 5	9 <sup>3</sup> / <sub>4</sub> x 5 <sup>1</sup> / <sub>2</sub> x 2

06.6535.6040

**Brotkorb**

bread-basket  
panier à pain  
cesta del pan  
cestino per il pane

nicht mit Wasser oder Chemikalien reinigen. Reinigung nur im  
Silbertauchbad oder mit speziellen Pflegemitteln für Silberartikel /  
do not clean with water or chemicals. Cleaning only in silver-dip-bath  
or with special polish for silver articles

versilbert / silverplated

Größe	size
cm	in.
22,3 x 16,3 x 6	8 <sup>3</sup> / <sub>4</sub> x 6 <sup>1</sup> / <sub>2</sub> x 2 <sup>1</sup> / <sub>4</sub>
27 x 19 x 6,5	10 <sup>3</sup> / <sub>4</sub> x 7 <sup>1</sup> / <sub>2</sub> x 2 <sup>1</sup> / <sub>2</sub>

19.6319.7030

19.6329.6440



**Brottschale**

bowl for bread  
panier à pain  
panera  
portapane

Größe	size
cm	in.
28 x 17	11 x 6 <sup>3</sup> / <sub>4</sub>

Cromargan®	versilbert
stainless 18/10	silverplated
<b>06.6380.6040</b>	<b>19.6380.6440</b>



**Brottschale**

bowl for bread  
panier à pain  
panera  
portapane

oval, Durchbruchdekor /  
oval, stencil pattern

Cromargan® / stainless 18/10

Größe	size
cm	in.
20 x 15	8 x 6

**06.6571.6040**



**Universalschale**

**PURE**

universal dish  
coupe universelle  
recipiente universal  
ciotola universale

stapelbar /  
stackable

Cromargan® teilmattiert / stainless 18/10 partly satin finished

Höhe	height	Ø Schale	dish Ø
cm	in.	cm	in.
5,5	2 <sup>1</sup> / <sub>4</sub>	12	4 <sup>3</sup> / <sub>4</sub>

**06.1799.6040**



**Universalschale**

finger bowl  
coupe universelle  
recipiente universal  
ciotola universale

Cromargan® / stainless 18/10

Inhalt	cap.	Ø Schale	dish Ø
Ltr.	oz.	cm	in.
0,2	7	12	4 <sup>3</sup> / <sub>4</sub>

**06.1849.6040**





**Obstschale  
BISTRO**

fruit stand  
coupe à fruits  
frutero  
alzata per frutta

Cromargan®, Glas / stainless 18/10, glass

Höhe	height	Ø Schale	Ø bowl
cm	in.	cm	in.
16	6 <sup>1</sup> / <sub>4</sub>	38	15

**06.6895.6040**

Ersatzteil / spare part:

Glasschale mittel / glass plate medium

19.9999.8644



**Obstschale**

fruit bowl  
coupe à fruits  
frutero  
alzata per frutta

Cromargan® / stainless 18/10

Größe	size
cm	in.
22,5 x 22,5 x 7,2	8 <sup>3</sup> / <sub>4</sub> x 8 <sup>3</sup> / <sub>4</sub> x 2 <sup>3</sup> / <sub>4</sub>

**06.8236.6040**





# TRENDS & THEMEN

trends & topics

Pure Exclusiv Colour

PVD-Besteck

PVD -cutlery

Hotelzimmer

rooms

Apartments

Glas

glass

Servierwagen

servicing trolleys

Küche

kitchen

Kaffeemaschinen

coffee machines

Eintönigkeit war gestern. Mit den neuen PVD-Beschichtungen von WMF können Sie Farbe ins Spiel bringen. PVD-beschichtetes Besteck kombiniert funktionelle Vorteile mit ganz neuen Gestaltungsmöglichkeiten. Geben Sie Ihrem Gedeck mit zusätzlichen Farbakzenten ein unverwechselbares Aussehen.

Bei dem hier abgebildeten Besteckmodell handelt es sich lediglich um ein Beispiel. Sie können jedes WMF Cromargan® Besteck in den hier dargestellten Farbvarianten beschichten lassen, ausgenommen hiervon sind aus technischen Gründen jedoch die Hohlheft-Messer.

Bitte beachten Sie, dass die Farbvarianten auftragsbezogen gefertigt werden. Näheres zu Preisen und Lieferzeiten erhalten Sie auf Anfrage.

Monochrome is out-of-date!  
With WMF's new PVD coatings, you can bring your cutlery to life with colour. PVD coated cutlery combines functional advantages with entirely new design possibilities. Give your table spread a distinctive look by adding some exciting colour accents.

The models shown here represent only some examples from the range. You can get any of the WMF Cromargan® cutlery models coated in the colours indicated. This excludes the hollow-handled knives due to technical constraints.

Please note that colour blends are made-to-order. Full details regarding pricing and delivery times are available on request.



Colour me!



**kupfer bronze (poliert)**  
copper bronze (polished)



**gold (poliert)**  
gold (polished)



**hellgold (poliert)**  
pale gold (polished)



**anthrazit (poliert)**  
gun metal (polished)

**WMF Besteck  
in trendigen  
Farben**  
WMF cutlery in  
trendy colours



## PURE EXCLUSIV COLOUR

Harmonie und Gleichklang sind die Komponenten, die jeden schönen Aufenthalt mit prägen. Bisher musste man sich dabei oft auf schwarz und weiß beschränken, um wirklich alle Accessoires aufeinander abstimmen zu können.

Das neue PURE EXCLUSIV COLOUR eröffnet dabei ganz neue Möglichkeiten. Bereits für geringe Stückzahlen können Sie die unendlich variablen Produkte von PURE EXCLUSIV farblich an Ihre Räumlichkeiten und farbigen Tischideen anpassen. Jeder RAL-Farbtone ist dabei realisierbar.

Mit WMF PURE EXCLUSIV COLOUR bringen Sie ganz einfach mehr Esprit auf jeden gedeckten Tisch.

## PURE EXCLUSIV COLOUR

Harmony and unity are the key components of any dining experience. Until now, one was generally only limited to white and black to ensure that all the accessories matched.

The PURE EXCLUSIV COLOUR range opens the world to new, exciting possibilities. With endlessly customizable PURE EXCLUSIV products, there are many new, colourful options for your establishment and table designs, even with comparatively few items. All RAL colour tones are available.

The WMF PURE EXCLUSIV COLOUR range will bring your table to life.



**RAL 9003**  
**Signalweiß**  
signal white



**RAL 3002**  
**Karminrot**  
carmine red



**RAL 4004**  
**Bordeauxviolet**  
claret violet



**RAL 6018**  
**Gelbgrün**  
yellow green

Bitte beachten Sie, dass die abgebildeten Farbtöne der PURE EXCLUSIV COLOUR Artikel nicht exakt den originalen RAL-Farbtönen entsprechen und lediglich einen kleinen Auszug aus der kompletten RAL-Edition darstellen!

Da die Farbvarianten auftragsbezogen gefertigt werden, erhalten Sie nähere Informationen zu Preisen und Lieferzeiten auf Anfrage.

Please note that the colour tones featured on the PURE EXCLUSIV COLOUR articles do not exactly match the actual RAL colour tones and represent only a small selection of the complete RAL colour tone edition.

The colour options are made-to-order. Full details regarding pricing and delivery times are available on request.



Weitere Artikel und Kombinationsmöglichkeiten aus der Serie PURE EXCLUSIV COLOUR finden Sie in der Broschüre PURE EXCLUSIV.



You can find more items and combination options from the PURE EXCLUSIV COLOUR series in the PURE EXCLUSIV brochure.



**Frische  
Farben gegen  
Eintönigkeit**  
Fresh New Colours  
– An End to  
Monochrome





Unser Roomservice - das Angebot an hochwertigen, stilvollen und funktionalen Artikeln, die sich sinnvoll in das Design Ihrer Zimmerausstattung integrieren lassen und Ihren Gast während seines Aufenthaltes begleiten.

Our room service - the range of high quality, stylish and functional products reasonably integrate in the design of your room furniture and accompany your guest during his residence.



Blumenvasen  
flower vases



Früchteschalen  
fruit bowls



Alle unsere Besteckmodelle im Überblick im Katalogteil I - „BESTECK“  
All our models as overview in catalogue part I - „FLATWARE“



Kaffee & Tee  
coffee & tea



Zucker- /und Milch-Sets  
sugar and milk sets



Saucen- und Dip-Menagen  
Stand for dips



Eiseimer  
ice bucket



Glas  
glass



Doppelwandkannen  
Double wall pots

Hotelzimmer  
rooms



Apartments liegen weltweit im Trend der Zeit und den Gast erfreut das Gefühl des Vertrauten. Mit unseren funktionalen, designorientierten Artikeln helfen wir, dass es sich ganz wie „Zuhause“ anfühlt.

Apartments meet the current trend worldwide and the guest enjoys the feeling of familiarity. With the aid of our functional, design orientated products it feels like "at home".



Alle unsere Besteckmodelle im Überblick im Katalogteil I - „BESTECK“  
All our models as overview in catalogue part I - „FLATWARE“



Seiher  
strainer



Gewürzmühlen  
spice mills



Pfannen  
pans



Kochtöpfe  
cooking pots



Messerserien  
kitchen knives



Kinder-Frühstück-Sets  
kids breakfast-sets



Glas  
glass



Porzellan  
porcelain



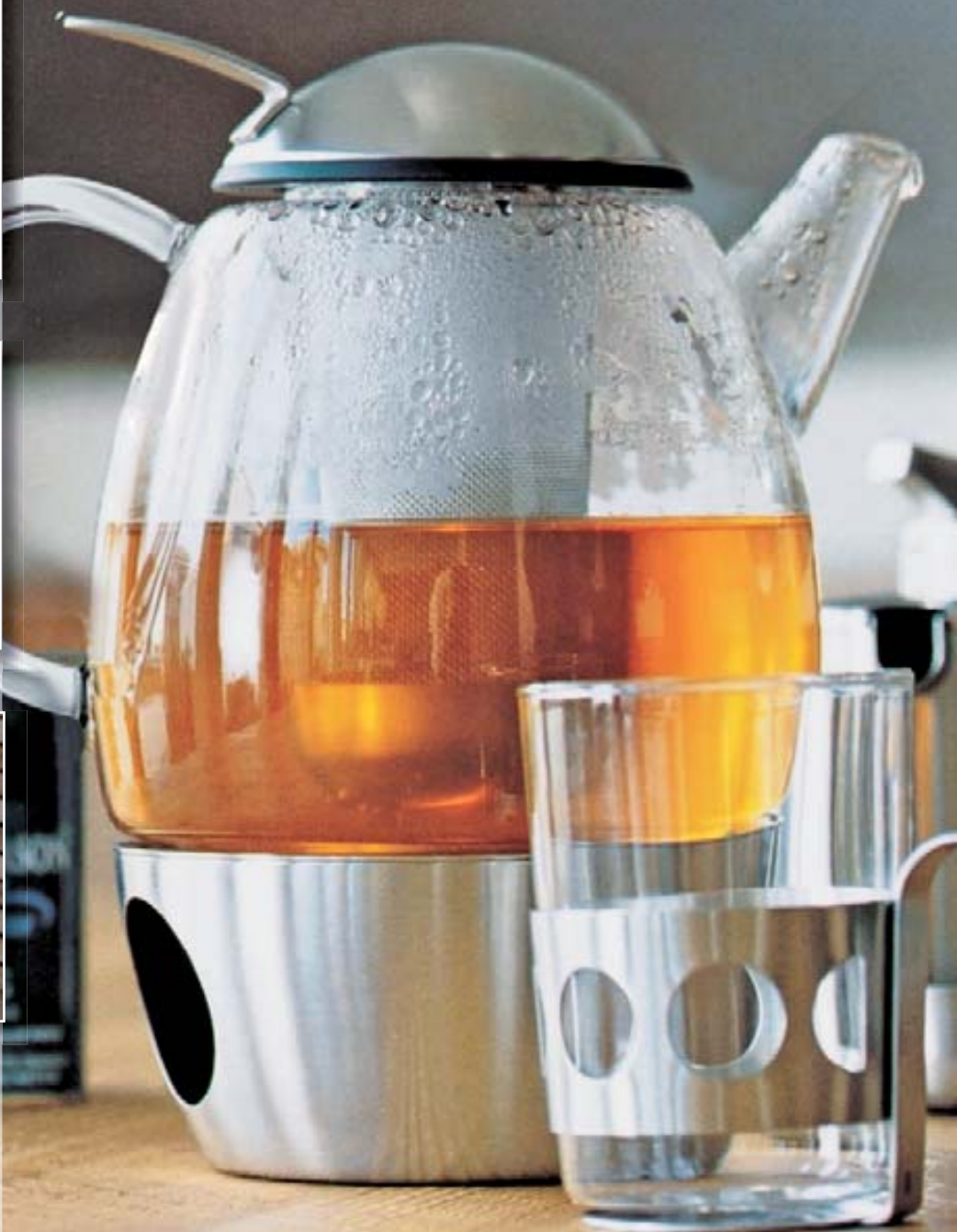

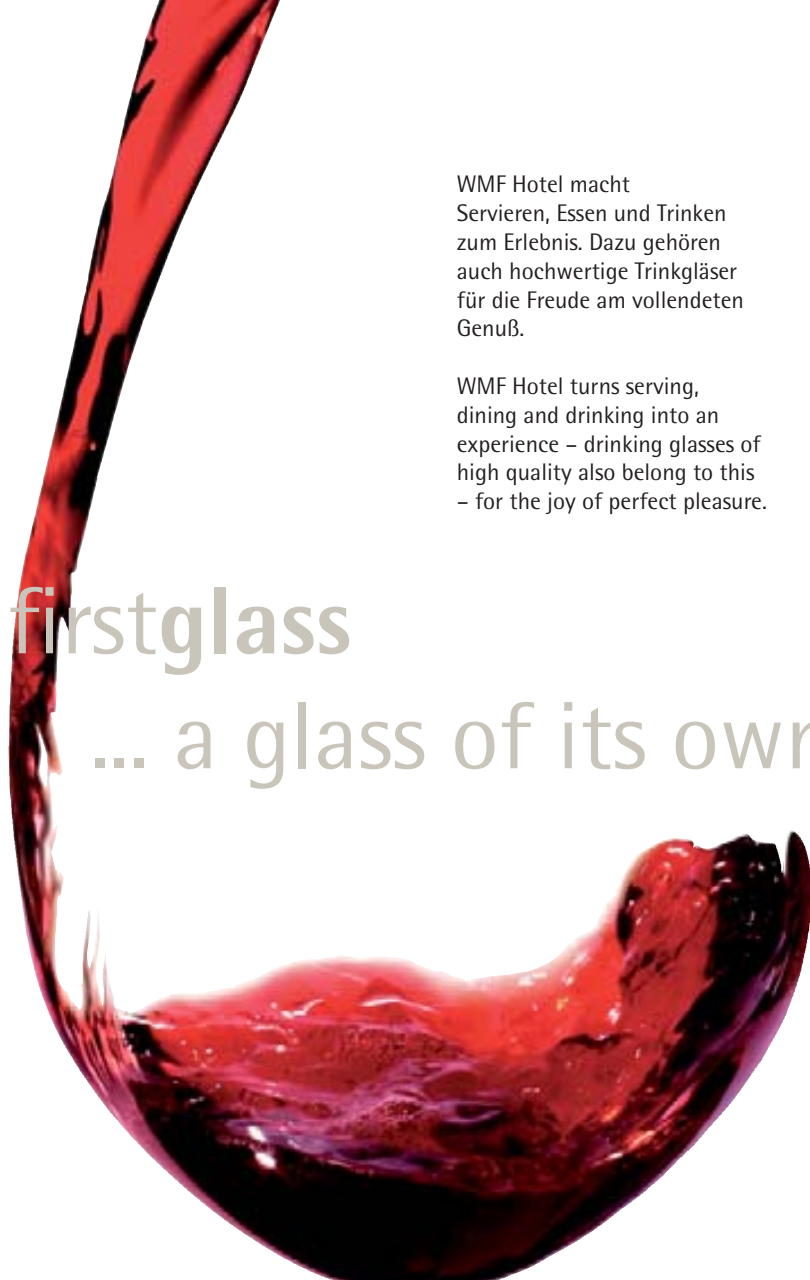

WMF Hotel macht  
Servieren, Essen und Trinken  
zum Erlebnis. Dazu gehören  
auch hochwertige Trinkgläser  
für die Freude am vollendeten  
Genuß.

WMF Hotel turns serving,  
dining and drinking into an  
experience – drinking glasses of  
high quality also belong to this  
– for the joy of perfect pleasure.

# WMF firstglass ... a glass of its own



Weitere Informationen  
zur Serie firstglass  
finden Sie in der  
gleichnamigen  
Broschüre.

## KOMPETENZ:

Kompetenz bedeutet für uns ein bleifreies Kristallglas, dessen Form und Brillanz den Ansprüchen der besten Weine gerecht wird. Eine zweckdienliche Gläserauswahl braucht keinen riesigen Gläserschrank, denn nur Glasformen, die geschmacklich wirklich nachvollziehbare Erlebnisse fördern, machen Sinn.

## COMPETENCE:

Competence means to us a lead-free crystal glass whose shape and brilliance meet the requirements of the best wines. A useful selection of glasses does not require a lot of storage as only glass shapes which complement the wine-tasting experience make sense.



You can find further  
information in the  
firstglass brochure.

## DESIGN:

Wie kein anderes Produkt spielt ein perfektes Glas seine Stärken dadurch aus, ein Präsentationsrahmen für das Besondere zu sein. Nicht die kleinste Unsauberkeit trübt den Blick nach Innen. Nicht der Werkstoff Glas muss wirken, sondern die feinen Spiegelungen und die weichen, fassenden Formen. Im perfekten Zusammenspiel bei WMF firstglass umrahmen sie den Inhalt und bringen ihn glänzend zur Geltung.

## DESIGN:

Like no other product a perfect glass highlights its quality by its form. No imperfections spoil the presentation of the wine. Not the material glass must act but the fine reflections and the soft, merging shapes. The composition of WMF firstglass gives shape and form to accentuate its content brilliantly.



Glas  
glass





WMF Hotel Servier- und Servicewagen passen einfach überall.  
3 Serien im Sortiment (Rondo, Royal, Bistro). Sonderfarben passend zu Ihrer Einrichtung gerne auf Anfrage.  
Das ganze Sortiment finden Sie in unserem Teilkatalog WMF Hotel Servier- und Servicewagen.

WMF Hotel serving and service trolleys fit in perfectly, anywhere.  
As well as the standard colours shown below, our serving and service trolleys are also available in custom colours according to your requirements or with different leg profiles – to suit your décor.

### Qualitätsmerkmale:

Ein Wagen, viele Funktionen. Durch das Wechseln der Einsätze können Sie den Servierwagen der Serien Bistro, Rondo und Royal z. B. in einen Käsewagen etc. verwandeln. So sparen Sie Geld und Platz für viele weitere Wagen.

### Quality features:

One trolley, lots of uses. By swapping over the top assemblies you can convert Bistro, Rondo and Royal series serving trolleys into a cheese trolley, for example. A feature which saves you money and the space needed for separate trolleys.



Unempfindlich gegen Feuchtigkeit durch wasserfesten Lack (keine stehende Nässe).  
Insensitive to moisture thanks to waterproof varnish (no stagnant water).



Praktische durchdachte Lösungen für den professionellen Einsatz.  
Practically thought-out solutions for professional use.



Leicht und leise zu bewegen durch hochwertige (z. T. vergoldete) Vollgummi-Lenkrollen.  
Light and easy to move on high-quality (some gold-plated) smooth rubber steering castors.



Hohe Tragkraft von 80 kg.  
Big load capacity of 80 kg.



Hohe Stabilität durch verdeckt integrierten Stahlrohrrahmen.  
Good stability, frame is reinforced with steel tube inside.



Robuste Rahmen und Kanten aus Massivholz.  
Sturdy frame and edges made from solid wood.

**Servierwagen**  
serving trolleys



Der harte Gastronomiealltag ist eine Herausforderung, der wir uns gerne stellen. Langjährige Erfahrung, ein umfangreiches Profi-Sortiment aus geprüften Materialien in einer hochwertigen Verarbeitung. Dies sind beste Voraussetzungen für unser „Küchenwerkzeug“.

The tough everyday catering trade is a challenge, to which we gladly rise. Experience of many years, an extensive professional assortment from compliant materials. These are the best qualifications for our "professional kitchen equipment".



Kochgeschirr  
cookware



Kochgeschirr  
cookware



Kochgeschirr  
cookware



Pfannen  
pans



Sauteusen  
saucepan



Seiher  
sieves



Rührbesen  
whisks



Küchenmesser  
kitchen knives



Schneidbretter  
cutting boards



Küchenkleininventar  
kitchen utensils



Küchengeräte  
kitchen equipment



Küchengeräte  
kitchen equipment



**Küche**  
kitchen



Unter einer Vielzahl verschiedenster Typen und Ausführungen finden Sie genau die Maschine, die den individuellen Anforderungen Ihres Betriebes gerecht wird.

Somewhere in the wide range of different models and versions you will find exactly the right machine to suit the particular requirements of your business.



WMF Kaffeekultur und Qualität made in Germany - weltweit. Tauchen Sie ein in die Welt der Kaffeervielfalt und lassen Sie sich verwöhnen.



WMF coffee culture and quality made in Germany - worldwide. Dip into the world of coffee variety and let your senses be spoiled.



Fordern Sie unverbindlich eines unserer Kaffeemaschinen Prospekte an oder informieren Sie sich über [www.wmf-kaffeemaschinen.de](http://www.wmf-kaffeemaschinen.de)  
Please, request one of our coffee machine folders or visit [www.wmf-coffeemachines.com](http://www.wmf-coffeemachines.com)



Kaffeemaschinen  
coffee machines







# Pflege | Reparatur maintenance | repair



**Material**  
material

**Aufarbeitung & Reparatur**  
refurbishment & repair

**Pflege-Tipps**  
maintenance

**Pflegemittel**  
cleaning aids

## Material:

Die WMF verarbeitet bei Bestecken und Tafelgeräten hauptsächlich korrosions- und säurebeständige Edelstähle (Cromargan®, Chromstahl), wobei Cromargan® teilweise mit einer Silberauflage veredelt wird.



### Cromargan®

- Cromargan® ist das eingetragene Warenzeichen der WMF für Edelstahl Rostfrei 18/10
- Edelstahl Rostfrei 18/10 Cromargan® wurde bereits 1927 für die WMF rechtlich geschützt.
- WMF verwendet Cromargan® für die Herstellung von Besteck, Kochgeschirr und vielen anderen Produkten.

### Eigenschaften

- auch bei intensivem Gebrauch unverwüstlich und pflegeleicht
- spülmaschinenfest
- temperaturwechselbeständig
- geschmacksneutral und beständig gegen alle Speisesäuren
- absolut hygienisch

### Chromstahl

Der von WMF eingesetzte Chromstahl weist eine sehr hohe Beständigkeit sowohl gegenüber Speisesäuren als auch bei der Beanspruchung in Geschirrspülmaschinen auf. Verwendet wird dieser Werkstoff für hochwertige Messerklingen.

### Silber

Bei Hotelartikeln wird Silber als Oberflächenbeschichtung, d.h. als galvanischer Niederschlag, verarbeitet. Basismaterial von versilberten Bestecken ist Cromargan®. Glanzversilbertes WMF Besteck zeichnet sich durch einen besonders hohen Gebrauchswert, in Verbindung mit dem festlichen Glanz des Silbers aus. Ein Besteck, das täglich benutzt werden kann und das noch nach vielen Jahren sein schönes Aussehen behält.

### Eigenschaften

- Metall mit dem höchsten Reflexionsvermögen
- absolut alltagstauglich
- antibakterielle Wirkung

## Material:

For cutlery and tableware WMF mainly uses:

High quality steels (Cromargan®, chrome steel) which are resistant to corrosion and acid, whereas Cromargan® is partly finished with silver plating.



### Cromargan®

- Cromargan® is the registered trademark of WMF for special stainless steel 18/10
- Cromargan® has registered in 1927 as a trademark of WMF
- WMF uses Cromargan® for the production of cutlery, cookware and a lot of other products.

### Characteristics

- indestructible and easy to clean even when intensively used
- dishwasher safe
- resistant to temperature changes
- tasteless and resistant to all food acids
- completely hygienic

### Chrome steel

The chrome steel used by WMF shows a very high resistance to food acids as well as to intensive use of dishwashers. This material is used for high quality knife blades.

### Silver

Silver is being used as surface coating, i.e. as a galvanic precipitate for hotel products.

Cromargan® is the basic material of silver plated cutlery. Polished silver plated WMF cutlery is characterized by a very high level of use in relation to the brilliance of the silver. A cutlery which can be used daily and keeps its beautiful look even after many years.

### Characteristics

- metal with the highest level of reflection
- completely suitable for daily use
- antibacterial effect



Material  
material

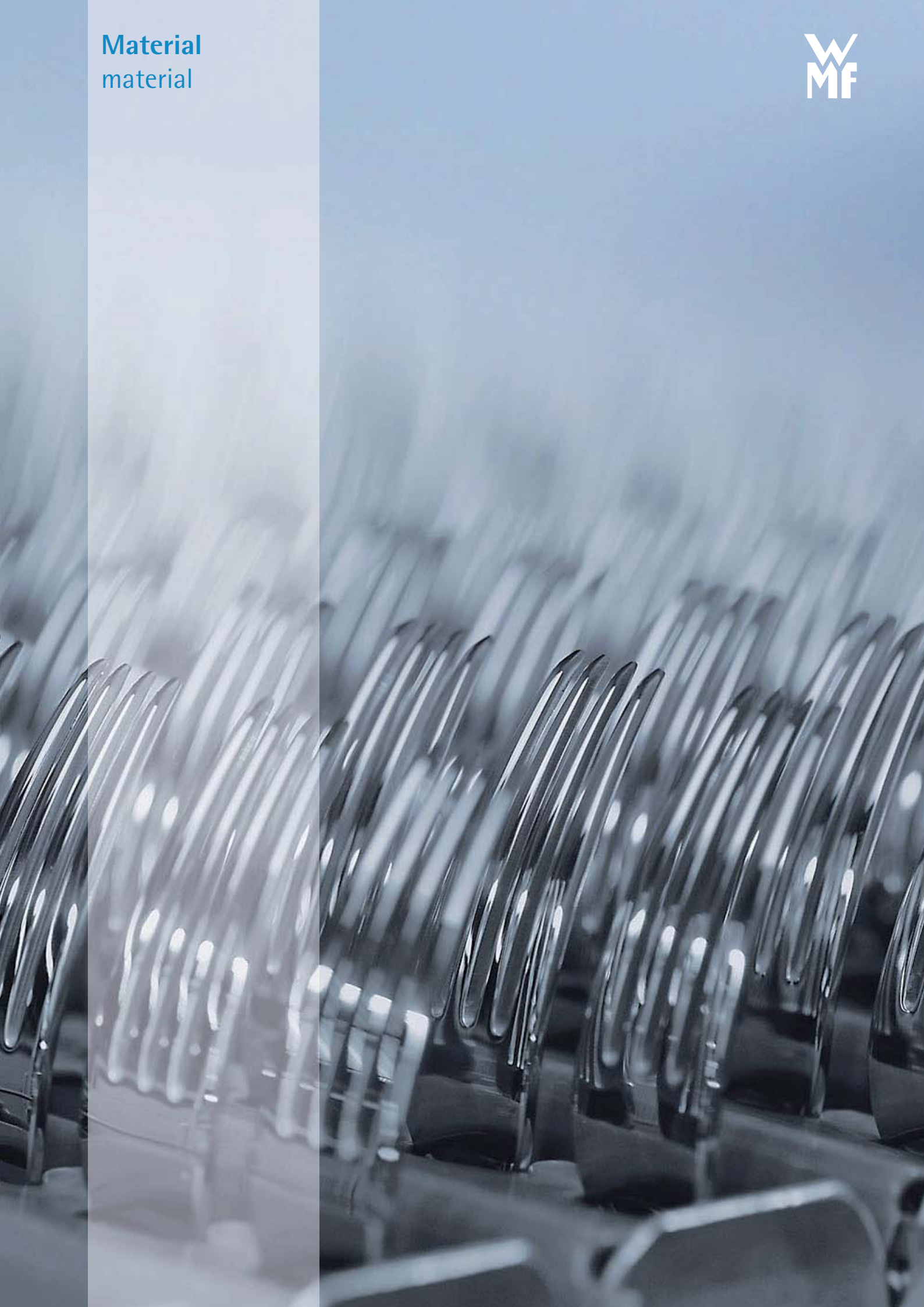





## Aufarbeitung & Reparatur

Aus alt mach neu – WMF Hotel ist nicht nur ein Anbieter qualitativ hochwertigster Produkte für den gedeckten Tisch und das Buffet, sondern bietet Ihnen auch den einzigartigen Service Ihre Produkte zu reparieren und aufzufrischen.

Nutzen Sie unser Know-how.

Unser Service-Team berät Sie gerne und erstellt Ihnen ein unverbindliches Angebot für folgende Service-Leistungen:

- Oberflächenbearbeitung von Serviergeräten und Bestecken: Polieren, Mattieren oder Sandstrahlen.
- Schweißen und Löten von z.B. Griffen und Scharnieren.
- Komplette Neuversilberung von Tablett, Kannen, Leuchter, etc.
- Ver- und Bearbeitung von Edelstahl, Messing, Neusilber, etc.
- Galvanikverfahren: Versilberung, Vergoldung, Verkupfern, Vernickeln, Verchromen.
- Erneuerung Wellenschliff bei Messern.
- Laserkennzeichnung / Stempelung / Gravuren sowie Ätzung von Bestecken und Serviergeräten.

Bitte wenden Sie sich bei Bedarf an Ihren zuständigen WMF Verkaufsberater oder nehmen Sie direkt Kontakt auf zu unserem Service-Team unter [info@WMF-Hotel.de](mailto:info@WMF-Hotel.de)

## Refurbishment & Repair

Make new from old – WMF Hotel is not only a supplier of high-class quality products for the table and the buffet but also offers an unique service to repair and polish up your products.

Take advantage of our know-how.

Our service team likes to advise you submits to you an offer without commitment for the following services:

- Processing of the surface of serving dishes and cutlery: Polishing, mat finishing or sandblasting.
- Welding and soldering of handles and hinges for example.
- Complete new silvering of serving trays, pots, candelabras, etc.
- Machining and processing of high quality steel, brass, new silver, etc.
- Electroplating process: silver, gold, copper, nickel and chromium plating.
- Renewal of serrated knives.
- Labelling with laser / stamping / engraving as well as etching of cutlery and service dishes.

For any requirements please apply to your responsible WMF sales agent or contact us directly under [info@WMF-Hotel.de](mailto:info@WMF-Hotel.de)

Aufarbeitung  
& Reparatur  
refurbishment &  
repair







## Pflege-Tipps

Ein gutes Besteck kann Sie über lange Zeit erfreuen. Dafür verdient es auch ein wenig Zuwendung und Pflege, damit eingetrocknete Speisereste, Feuchtigkeit oder falsches Handling diesem nicht dauerhaft Schaden. Alle WMF Bestecke in der original WMF Legierung Cromargan® sind spülmaschinenfest. Damit Ihr Besteck immer so schön bleibt wie am ersten Tag, hier einige Pflgetipps:

- Reinigen Sie Ihr Besteck nach Gebrauch von groben Speiseresten und lassen Sie es nie längere Zeit ungespült liegen.
- Besteck darf nicht eingeweicht werden oder längere Zeit feucht liegen bleiben.
- Beim Waschen in der Spülmaschine stellen Sie die Besteckteile mit dem Griff nach unten in den Korb. Sie vermeiden Kratzer, indem Sie Bestecke unterschiedlicher Art getrennt voneinander spülen.
- Nehmen Sie Ihr Besteck möglichst bald nach Beendigung des Spülgangs aus der Maschine und trocknen Sie es bei Bedarf ab. Falls dies nicht möglich ist, öffnen Sie bitte die Tür der Maschine, damit der Dampf abziehen kann und kein Feuchtigkeitsstau entsteht.
- Wir empfehlen, nach dem Auffüllen Ihrer Spülmaschine mit Regeneriersalz einen Leerspülgang durchzuführen.
- Verwenden Sie nur hochwertige Geschirrspülmittel, und beachten Sie die Hinweise auf den Packungen der Spülmittel, damit Sie stets mit einem glänzenden Ergebnis rechnen können. Beachten Sie auch die Gebrauchsanleitung Ihrer Geschirrspülmaschine.

Für Bestecke mit perfekter Glanzversilberung gelten folgende Pflegehinweise:

Sie sind spülmaschinenfest und im täglichen Gebrauch unkompliziert. Falls Ihr Silberbesteck längere Zeit nicht benutzt wurde, empfehlen wir das WMF Purargan® Silberpflegemittel.

## Maintenance

A good cutlery can please you for a long time. For this reason it deserves a little attention and care so that dried up leftovers, humidity and wrong handling causes durable damage.

All WMF cutlery models in the original WMF alloy Cromargan® are dishwasher safe. For keeping your cutlery as beautiful as on the first day, please see the following care hints:

- After use please clean your cutlery of rough leftovers and do not leave it uncleaned for any length of time.
- Cutlery must not be soaked or left damply for any length of time.
- When cleaning in the dishwasher please put the cutlery items with the handle on bottom in the basket. You avoid scratches when cleaning cutleries of different types separately.
- Take your cutlery out of the dishwasher as soon as possible after ending of the cleaning process and dry it if necessary. If this is not possible please open the door of the dishwasher so that the damp can move off and no humidity accumulation can occur.
- We recommend making a cleaning process with the empty dishwasher first after refilling the regenerating salt.
- Use only high quality cleaning products and pay attention to the advices on the packages of the washing-up liquids so that you can always expect a brilliant result. Pay also attention to the operation instructions of your dishwasher.

For cutlery with perfect polished silver plating the following care advices are valid:

They are dishwasher safe and uncomplicated in daily use. If the silver cutlery is not being used for any length of time we recommend the WMF Purargan® silver care product.



Pflege-Tipps  
maintenance







**Purargan® Silbertauchbad**

Purargan®-silver-dip-bath  
 Purargan®-bain à immersion pour l'argenterie  
 Purargan®-baño de inmersión limpiaplata  
 Purargan®-bagno ad immersione per la pulizia dell'argento

Zur regelmäßigen Behandlung versilberter Teile mit leichtem bis mittleren Anlauf. /  
 For regular care of silverplated items with slight to medium tarnish.

Inhalt	cap.	
Ltr.	oz.	
5	175	<b>14.2826.9990</b>



**Purargan® C, -Pflegemittel für Silber, Messing und Kupfer**

Purargan® C, -silver, brass and copper polish  
 Purargan® C, -produit de nettoyage pour l'argenterie, laiton et cuivre  
 Purargan® C, -limpia-plata, latón y cobre  
 Purargan® C, -liquido per la pulizia dell'argento

geeignet für starken Anlauf und gleichzeitiges Aufpolieren der Oberfläche der Produkte /  
 suitable for heavy tarnish and also for polishing the surface of the products

Inhalt	cap.	
Ltr.	oz.	
1	35	<b>14.2828.9990</b>



**Purargan® forte, -Pflegemittel für Silber, Messing und Kupfer**

Purargan® forte, -silver, brass and copper polish  
 Purargan® forte, -produit de nettoyage pour l'argenterie, laiton et cuivre  
 Purargan® forte, -limpia-plata, latón y cobre  
 Purargan® forte, liquido per la pulizia dell'argento

geeignet für leichten bis mäßigen Anlauf, enthält Wiederanlauf-Schutz /  
 suitable for slight to moderate tarnish; contains anti-tarnish protection

Inhalt	cap.	
Ltr.	oz.	
1	35	<b>14.2831.9990</b>



**Purargan®-Silber-Pflegetuch**

Purargan®-silver polishing cloth  
 Purargan®-chiffon nettoyeur pour argenterie  
 Purargan®-pañó de limpieza para platería  
 Purargan®-panno per la cura dell'argento

Reinigt und schützt durch Polieren vor Anlauf von Silber, Kupfer, Messing und Zinn. /  
 Cleans and polishes to protect silver, copper, brass and tin from tarnishing.

**14.2822.9990**



Artikel	Seite	Artikel	Seite	Artikel	Seite
"4 for you" - Löffel	60	Ess-Stäbchen Ablage	62	Mokkaétagère	111, 214
Abdeckhaube	154, 218, 224	Ess-Stäbchen Paar	62	Nudellöffel	51
Adapter für Elektroheizteil	188	Ess-Stäbchen Set	62	Obstschale	121, 227
Allround "CultureCup-Set"	67	Etagère	158, 213 - 215	Parmesanreibe mit Behälter	51
Allround "KaffeeKultur-Set"	71	Flaschenteller	97	Petits Fours-Ständer	112 - 113
Ascher	117	Fleischgabel	50	Plastik-Tischnummer	132
Asia-Set	141	Früchtekorb	119, 158, 216, 225	Platte	152 - 153, 185
Bargestell	115	Gastronorm-Einsatz	186	Platten	218
Beilagenschale	157	Gebäck- und Servierzange	52	Plattenständer hoch	217
Besteckablage	190 - 191	Getränkekühler	98, 209	Plattenständer niedrig	217
Besteckbaum	159	Glas LATTE (VPE 6 Stk.)	67	Platzteller	102
Blumenvase	127 - 128	Glas S (VPE 6 Stk.)	68	Plexiglashülle S	160
Bowlenlöffel	54	Glasbehälter	75	Portions-Chafing Dish	179
Brennstoffdose	190	Glaskrug	155	Portionsschöpfer	55
Brennstoffdosenhalter	189 - 190	Glasschale	157 - 158, 215	Porzellanbehälter	69, 74
Brennstoffhalter Coffee Urn	194	Gläser-Set	76	Porzellan-Einsatz	182, 184 - 185, 187
Brille	156	Grundreling L	148	Porzellan-Einsätze	185
Brotkorb	119, 225	Grundreling M	148	Porzellankugel	156 - 157
Brotmesser	56	Happy Spoon	59	Porzellanschale	91, 113
Brotschale	120, 226	Heizelement	150, 188 - 189	Porzellantasse M flach mit Griff	68
Buffetgestell	171 - 173	Heizelement Coffee Urn	194	Porzellantasse M hoch mit Griff	68
Buffet-Set	210 - 211	Honig-/Sahnespender	83	Porzellantasse S mit Griff	68
Butterkühler	105 - 107	Hummergabel	53	Punchbowl	93 - 94
Café au Lait-Set	71	Hummerzange	53	Purargan® C	254
Café Crème-Set	66, 70	Hygieneschutz	160	Purargan® forte	254
Cappuccino-Set	66	Kaffeebereiter	78	Purargan® Silbertauchbad	254
Ceralien-/Saft-Set	210	Kaffeekanne	78 - 80, 82	Purargan®-Silber-Pflegetuch	254
Cerealien-/Saft-Set	210	Kaffeetablett	91, 219	Rahmen	151 - 152
Cerealien-/Saft-Set	210	Kartenhalter	131	Relish-Pickles-Gestell	114 - 115
Cerealien-/Saft-Set	210	Kartoffellöffel	55	Rotweinwiege	93
Cerealien-/Saft-Set	210	Kaviarkühler	109	Saftbar	206
Cerealien-/Saft-Set	210	Kaviarlöffel	59	Saftdispenser	204
Cerealien-/Saft-Set	210	Kaviarmesser	59	Sahne-/Zucker-Set	73
Cerealien-/Saft-Set	210	Kinderset	63	Sahnegießer	82
Cerealien-/Saft-Set	210	Korkenzieher	61	Sahnekännchen	74
Cerealien-/Saft-Set	210	Krümelsammler	116	Sahnekännchen (VPE 6 Stk.)	74
Cerealien-/Saft-Set	210	Kuchen-/Tortenplatte	224	Sahne-Zucker-Set	84 - 85
Cerealien-/Saft-Set	210	Kühlakku	155, 217	Salat-/Vorlegebesteck	50
Cerealien-/Saft-Set	210	Kühlbehälter	159, 216	Salatzeige	51
Cerealien-/Saft-Set	210	Kühlelement	98, 209	Salz- und Pfeffergestell	134
Cerealien-/Saft-Set	210	Käsedose	143	Salz-/Pfeffer-Set	140
Cerealien-/Saft-Set	210	Käseglocke	224	Salzmühle / Pfeffermühle	133
Cerealien-/Saft-Set	210	Käsemesser	60	Salzstreuer / Pfefferstreuer	133
Cerealien-/Saft-Set	210	Latte Macchiato-Set	66, 70, 76	Saucenlöffel	54
Cerealien-/Saft-Set	210	Légumier	104 - 105	Sauciere	104
Cerealien-/Saft-Set	210	Leuchter	122 - 123	Schild mit Kette	194
Cerealien-/Saft-Set	210	Löffel "CultureCup"	69	Schneckengabel	53
Cerealien-/Saft-Set	210	Löffel "KaffeeKultur"	60	Schneckenzange	54
Cerealien-/Saft-Set	210	Marmeladegestell	113	Schreibtafel S	160
Cerealien-/Saft-Set	210	Menage	108, 142	Senftopf	143
Cerealien-/Saft-Set	210	Milchdispenser	205	Serviergestell	109, 213
Cerealien-/Saft-Set	210	Milchkaffee-Set	70	Serviertablett für Zucker	83
Cerealien-/Saft-Set	210	Milchkanne	79 - 81	Speisekartenhalter	131
Cerealien-/Saft-Set	210	Milchkännchen	90	Steakbesteck	58
Cerealien-/Saft-Set	210	Milch-Zucker-Set	84, 86 - 89	Steakbesteck SOLID	58
Cerealien-/Saft-Set	210			Steakmesser	58
Cerealien-/Saft-Set	210			Steakmesser*	58

Artikel	Seite
Suppenmarmite	182 - 184
Suppenschöpfer	55
Suppenstation	183
Tablett	67, 92, 114, 135, 152 - 153, 159, 215, 219 - 224
Tablett Gastronorm	221 - 222
Teeglas	76
Teekanne	78 - 80, 82
Teelichtleuchter 3fl. klein	126
Teesieb	77 - 78
Teesieb-Behälter	77, 79
Teesieb-Einsatz	77
Teller-/Schalengestell	211
Tellercloche	102 - 103
Tischnummer	131
Tischnummern-Aufsteller	130
Tischnummernständer	129 - 130
Tischrestebehälter	116
Toastständer	114
Tortenheber	59
Tortenmesser	60
Tranchiergabel	57
Tranchiermesser	57
Universalschale	105, 120, 226
Universalzange	52
Vorlege-/ Aufschnittgabel	56
Wandhalterung Cer.disp.	199 - 200
Wein-/Sektkühler	94 - 95
Weinkorb	93
Weinkühler	95
Weinkühlerständer	96
Windlicht	124 - 125
Zahnstocher- und Süßstoffbehälter	91, 117, 132, 142
Zahnstocherbehälter	117
Zigarrenabschneider	118
Zitronenpresse	77
Zuckerdose	80 - 81, 90
Zuckerdosierer	83
Zuckergestell	83, 85
Zuckerstangengefäß	90
Zuckerzange	53

Article	Page	Article	Page	Article	Page
"4 for you" spoon	60	egg cup set	116	oil and vinegar set	134 - 139,
4-pc. child's set	63	egg spoon	56, 116		142
all-round "CultureCup Set"	67	espresso double set	71	oil/vinegar bottle	135
all-round "KaffeeKultur Set"	71	espresso set	66, 70		
ash tray	117	etagere	158,	<b>parmesan grater with</b>	
Asia set	141		213 - 215	storage box	51
		extension rail L	148	parmesan jar	143
<b>bar-relish dish</b>	115	extension rail M	149	pasta serving spoon	51
basic rail L	148			pastry serving tongs	52
basic rail M	148	<b>finger bowl</b>	105, 120,	pastry stand	111, 214
beverage cooler	98, 209		226	petits-fours-stand	112 - 113
blackboard S	160	flower vase	127 - 128	pie server	59
bowl for bread	119 - 120,	frame	151 - 152,	plastic table number	132
	225 - 226	fruit basket	171 - 173	plate and bowl stand	211
bowl for ingredients	157		119, 158,	plate cover	102 - 103
bread knife	56		216, 225	plate tray	102
bread-basket	119, 225	fruit bowl	121, 227	platter	152, 185
buffet set	210 - 211	fruit stand	121, 227	platter Gastronorm	153
burner holder	189 - 190			platters	218
burner holder coffee urn	194	<b>glass bowl</b>	157 - 158,	plexi glass frame S	160
butter cooler	105 - 107		215	porcelain bowl	156 - 157
		glass dish	75	porcelain bowl 3-section	91, 113
<b>café au lait set</b>	71	glass LATTE (unit 6 pcs.)	67	porcelain cup M	
café crème set	66, 70	glass pitcher	155	high with handle	68
caffè Latte set	70	glass S (unit 6 pcs.)	68	porcelain cup M	
cake knife	60	glass set	76	low with handle	68
cake plate	224	GN insert	186	porcelain cup S with handle	68
can opener	61	GN porcelain insert	187	porcelain dish	69, 74
candelabra	122	gravy boat	104	porcelain insert	182,
candle stick	123	gravy ladle	54		184 - 185
cappuccino set	66			potato spoon	55
card holder	131	<b>happy spoon</b>	59	punch bowl	93 - 94
carving knife	57	heating element	150,	punch bowl ladle	54
caviar cooler	109		188 - 189,	Purargan® C	254
caviar knife	59		194	Purargan® forte	254
caviar spoon	59	holder for heating element	188	Purargan®-silver polishing	
cereal dispenser	198 - 199	honey/cream dispenser	83	cloth	254
Chafing Dish	149 - 150,	hygienic cover	160	Purargan®-silver-dip-bath	254
	170 - 171,				
	176 - 180	ice bucket	100 - 101	rack for utensils	190 - 191
chafing dish serving set	50, 192	ice cream bowl	110	red wine cradle	93
cheese dish	224	ice spoon XL	61	relish or condiment server	114 - 115
cheese knife	60	ice tongs	52		
chillcup	110	ice tray	154 - 155	salad serving tongs	51
chopstick set	62	ice tube	206	salad/buffet serving set	50
chopstick stand	62	ice-shovel	55	salt and pepper set	140
chopsticks pair	62	insert for chafing dish	184	salt mill / pepper mill	133
cigar cutter	118	insert holder	156	salt shaker / pepper shaker	133
coaster for bottles	97			salt-pepper-set	134
coffee pot	78 - 80,	<b>jam stand</b>	113	service tray	159, 215
	82	juice bar	206	serving fork	50, 56
coffee press	78	juice dispenser	204	serving stand	109, 213
coffee urn	193			serving tray	67,
cooler	159, 216	latte macchiato set	66, 70, 76		91 - 92,
cooling block	155, 217	lemon/orange squeezer	77		114,
cooling element	98, 209	lid with cut-out	69, 73		152 - 153,
cork-screw	61	lobster fork	53		219 - 224
cover for trays	154, 218,	lobster-crack	53	servicing tray for sugar	83
	224			servicing tray Gastronorm	221 - 222
creamer	74, 82, 90	<b>meat fork</b>	57	set for cereal/juice dispenser	210
creamer (unit 6 pcs.)	74	menage	108, 142	silent waiter	116
		menu stand	131	single items "KaffeeKultur"	72
<b>dessert stand</b>	107 - 109,	milk dispenser	205	snail fork	53
	211 - 213	milk jug	79 - 81	snail tweezer	54
dressing insert	158	mustard pot	143	solid alcohol	190
dressing ladle	54			soup ladle	55
		<b>name plate with chain</b>	194	soup tureen	182 - 184

Article	Page
spoons "CultureCup"	69
spoons "KaffeeKultur"	60
stand for wine/champagne cooler	96
steak flatware	58
steak fork and knife SOLID	58
steak knife	58
steak knife*	58
sugar and creamer set	84
sugar and milk set	73, 85 - 89
sugar basin	80 - 81, 90
sugar dispenser	83
sugar pack holder	90
sugar server	83
sugar set	85
sugar tongs	53
table crumbler	116
table lamp	124 - 125
table lamp with glass	124
table number	130 - 131
table number stand	129 - 130
tea glass	76
tea pot	78 - 80, 82
tea strainer	77 - 78
tea strainer holder	77, 79
tea strainer insert	77
tealight candle stick	126
toast rack	114
toothpick- and sweetener box-holder	91, 117, 132, 142
toothpick-holder	117
tray	135, 220
tray stand high	217
tray stand low	217
universal dish	105, 120, 226
utensil holder	159
vegetable dish and cover	104 - 105
wall mount for cer. disp.	199 - 200
water pitcher	99 - 100
wine / champagne cooler	94 - 95
wine cooler	95
wine-basket	93

<b>Article</b>	<b>Page</b>	<b>Article</b>	<b>Page</b>	<b>Article</b>	<b>Page</b>
adaptateur pour plaque électrique	188	cuiller à punch	54	panier à fruits	119, 158, 216, 225
alcool solidifié	190	cuiller à sauce	54	panier à pain	119 - 120, 225 - 226
articles isolés "KaffeeKultur"	72	cuillère à spaghetti	51	panier à vin	93
assiette de présentation	102	cuillers "CultureCup"	69	passoire	77
		cuillers "KaffeeKultur"	60	passoire à thé	77 - 78
<b>bac réfrigérant</b>	154 - 155	<b>dessous de bouteille</b>	97	pelle à gâteau	59
baguettes paire	62	dispenseur de céréales	198 - 199	pichet à eau froide	
bar à jus de fruit	206	dispenseur de jus	204	double paroi	100
bati	171 - 173	dispenseur de lait	205	pince à escargots	54
boîte de table	116	distributeur à miel / crème	83	pince à gâteau	52
bol à punch	93 - 94	double fixation murale p. disp. à céréales	200	pince à glace	52
bol à verre	157	<b>élément réfrigérante</b>	98, 209	pince à homard	53
bol de acero	157	<b>ensemble buffet</b>	210 - 211	pince à salade	51
boule porcelaine	156 - 157	étagère	158, 213 - 215	pince à sucre	53
brique réfrigérante	155, 217	étagère à couverts	159	planche Gastronorm pour recipient	153
broc en verre	155	étiquette avec chaîne	194	planche pour recipient	152, 218
burette à vinaigre/huile	135	<b>fourchette à escargots</b>	53	plaque électrique	150, 188 - 189, 194
		fourchette à homard	53	plat	185
<b>cadre</b>	151 - 152	fourchette à viande	50, 56 - 57	plat à tarte	224
cafetière	78 - 80, 82	<b>fromagère</b>	143	plateau	135, 220
cafetière à piston	78	<b>garniture pour saucière</b>	158	plateau de service	67, 91 - 92, 114, 152 - 153, 159, 215, 219 - 224
carafe à l'eau	99	GN intérieur	186	plateau de service Gastronorm	221 - 222
carafe à l'eau	99	GN intérieur en intérieur	187	plateau de service pour sucre	83
cendrier	117	<b>happy spoon</b>	59	plateau pléxiglas	160
Chafing Dish	149 - 150, 170 - 171, 176 - 180	huilier-vinaigrier	134 - 139, 142	plateau pléxiglas S	160
	122 - 123	<b>intérieur en porcelaine</b>	182, 184 - 185	porte brûleur	189 - 190
chandelier	124 - 125	intérieur pour chafing dish	184	porte brûleur coffee urns	194
chandelier avec verrine		<b>kit "CultureCup" polyvalent</b>	67	porte menu	131
chandelier bougie		kit "KaffeeKultur" polyvalent	71	porte numéro de table	129 - 130
à chauffe-plat	126	kit ASIA	141	porte petits fours	111 - 113, 214
chillcup	110	kit baguettes	62	porte-bouteille	93
cloche à fromage	224	kit café au lait	70 - 71	porte-carte	131
cloche pour assiette	102 - 103	kit café crème	66, 70	porte-cure-dents	117
cloche pour plateaux	154, 218, 224	kit cappuccino	66	porte-cure-dents et récipient pour sucrées	91, 117, 132, 142
coffee urn	193	kit espresso	66, 70	pot à lait	79 - 81
coupe à fruits	121, 227	kit espresso double	71	pots à lait	90
coupe à glace	110	kit latte-macchiato	66, 70	pots à sucriers	90
coupe en porcelaine 3 parties	91, 113	<b>latte-macchiato-set</b>	76	présentoir à assiette	109, 213
coupe réfrigérante	159, 216	légumier et couvercle	104 - 105	présentoir a cereales/jus de fruit	210
coupe universelle	105, 120, 226	louche	55	présentoir à gâteau	107 - 109, 211 - 213
		louche à potage	55	presse-citron	77
coupe verre glasskin	158, 215	<b>marmite à potage</b>	182 - 184	Purargan® C	254
coupe-cigares	118	menagère	108, 142	Purargan® forte	254
couteau à caviar	59	menagère 2 pièces	134	Purargan®-bain à immersion pour l'argenterie	254
couteau à fromage	60	menagère 3 pièces	140	Purargan®-chiffon nettoyeur pour argenterie	254
couteau à pain	56	moulin à sel / moulin à poivre	133		
couteau à steak	58	moutardier	143	<b>ramasse-brosse</b>	116
couteau à steak*	58	<b>numéro de table</b>	130 - 131	rangement pour baguettes	62
couteau à tarte	60	numéro de table en plastique	132	râpe à parmesan avec oite fraicheur	51
couteau à viande	57	<b>ouvre-boîte</b>	61		
couvercle avec découpe	69, 73				
couvert à salade/servir	50				
couvert à steak	58				
couvert à steak SOLID	58				
couvert enfant	63				
crémier	74, 82				
crémier (UV 6 pc.)	74				
cuiller "4 for you"	60				
cuiller à caviar	59				
cuiller à glace	55				
cuiller à glace XL	61				
cuiller à oeuf	56, 116				
cuiller à pommes de terre	55				



<b>Article</b>	<b>Page</b>
réceptacle en porcelaine	69, 74
réceptacle en verre	75
refraîchisseur à beurre	105 - 107
refraîchisseur à caviar	109
saucière	104
saupoudreuse à sucre	83
seau à boisson	98, 209
seau à glace	100 - 101
seau à vin	95
seau à vin / champagne	94 - 95
service à relish	114 - 115
service à sucre	83
service à sucriers	85
service pots à lait / sucriers	73, 84 - 89
service pour chafing dish	50, 192
set à glass	76
set de coquetier	116
simple fixation murale pour disp. à céréales	199
soucoupe pour passoire à thé	77, 79
sucrier	80 - 81, 90
support	156
support 3 barres de base L	148
support 3 barres de base M	148
support 3 barres supplémentaire L	148
support 3 barres supplémentaire M	149
support couverts à servir	190 - 191
support pour bols à céréales	211
support pour confiture	113
support pour pain grillé	114
support pour plaques bas	217
support pour plaques haut	217
support pour seau à champagne	96
tableau S	160
tasse en porcelaine M haute avec anse	68
tasse en porcelaine M plate avec anse	68
tasse en porcelaine S avec anse	68
théière	78 - 80, 82
tire-bouchon	61
tube à glace	206
vase à fleurs	127 - 128
verre à thé	76
verre LATTE (UV 6 pc.)	67
verre S (UV 6 pc.)	68

Articulo	Página	Articulo	Página	Articulo	Página
abrelatas	61	cucharas "CultureCup"	69	juego universal para el	
acumulador refrigerador	155, 217	cucharas "KaffeeKultur"	60	"KaffeeKultur"	71
adaptador para placa		cucharon patatas	55	juego vasos	76
calentadora	188	cuchillo carne	57		
árbol cubertero	159	cuchillo caviar	59	lechera	79 - 81
artículos diversos		cuchillo pan	56	legumbreira con tapa	104 - 105
"KaffeeKultur"	72	cuchillo queso	60	linterna con cristal	124 - 125
azucarero	80 - 81, 90	cuchillo steak	58		
azucarero para azúcar		cuchillo steak*	58	marco	151 - 152
en cañas	90	cuchillo tarta	60	marco de metacrilato S	160
		cuenco de porcelana		molinillo sal / molinillo	
		3 divisiones	91, 113	pimienta	133
bajoplató	102	depósito para chafing dish	184	mostacero	143
bandeja	67, 91 - 92, 114, 135, 152 - 153, 159, 215, 219 - 224	depósitos de cristal	157 - 158, 215	número de mesa	130 - 131
bandeja con azucareros	83	dispensador de cereales	198 - 199	número de mesa plástico	132
bandeja Gastronorm	221 - 222	dispensador de zumo	204		
bandeja para hielo	154 - 155	dispensador leche	205	pala para hielo	55
bol de acero	157	dispensador miel / nata	83	pala para hielo XL	61
bola de porcelana	156 - 157	dosificador azúcar	83	pala tarta	59
botella de aceite/vinagre	135			palillero	117
		elemento refrigerador	98, 209	palillero y dispensador	
		enfriador caviar	109	de edulcorante	91, 117, 132, 142
		enfriador para		panera	119 - 120, 225 - 226
		mantequilla	105 - 107		
		etiqueta con cadena	194	pinza caracoles	54
cafetera	78 - 80, 82	exprimidor para limones	77	pinza de azúcar	53
cafetera de émbolo	78			pinza hielo	52
campana	103	florero	127 - 128	pinza para ensalada	51
campana con pomo	102	frutero	119, 121, 158, 213 - 214, 216, 225, 227	pinza para langostas	53
campana para bandejas	154, 218, 224			pinza pasteles	52
		frutero articulado	158, 215	pizarra S	160
candelabro	122	fuelle	152, 185, 218	placa calentadora	150, 188 - 189, 194
candelero	123			place calentadora	189
candelero lamparilla	126	fuelle Gastronorm	153	plato tarta	224
cazo ponche	54			ponchera	93 - 94
cazo porciones	55	GN interior	186	porta aperitivos	114 - 115
cazo salsa	54	GN interior porcelana	187	porta menus	131
cazo sopa	55			porta número de mesa	129 - 130
cenicero	117	happy spoon	59	porta número de mesa	
cesta del pan	119, 225			(sin grabación)	130
cesta vino	93	interior colador té	77 - 78	porta número de mesa	
Chafing Dish	149 - 150, 170 - 171, 176 - 180	interior de porcelana	185	(sin número)	129
		interior porcelana	182, 184 - 185	portabotella	97
combustible	190			portabotellas	93
copa cóctel mariscos	110	jarra agua	99 - 100	portacubos champán	96
copa helado	110	jarra de cristal	155	portapastas	111 - 113, 214
cortapuros	118	juego ASIA	141	portatarjetas	131
cremera	74, 82, 90	juego azúcarero	85	portatostadas	114
cremera (UV 6 p.)	74	juego azúcarero / cremera	73, 84 - 89	protector higiénico	160
cubierto ensalada/servir	50			Purargan® C	254
cubierto niño	63	juego café con leche	70 - 71	Purargan® forte	254
cubierto servir chafing dish	50	juego café-crème	66, 70	Purargan®-baño de inmersión	
cubierto steak	58	juego capuchino	66	limpiaplata	254
cubierto steak SOLID	58	juego de bufete	210 - 211	Purargan®-pañó de limpieza	
cubiertos para chafing dish	192	juego de palillos	62	para platería	254
cubo bebida	98, 209	juego espresso	66, 70		
cubo hielo	100 - 101	juego espresso doble	71	quesera	224
cubo vino	95	juego latte macchiato	66, 70, 76		
cubo vino / champán	94 - 95	juego palillos	62	rallador queso	51
cuchara "4 for you"	60	juego universal para el		recipiente	143, 159, 216
cuchara caviar	59	"CultureCup"	67	recipiente colador	77
cuchara huevos	56, 116				
cuchara pasta	51				

<b>Articulo</b>	<b>Página</b>
recipiente colador té	77, 79
recipiente de cristal	75
recipiente de porcelana	74, 185
recipiente de procelana	69
recipiente desperdicios	116
recipiente para salsas	158
recipiente sopa	182 - 183
recipiente universal	105, 120, 226
recogemigas	116
sacacorchos	61
salsera	104
servicio condimento	134, 140
servicio de azúcar	83
set 3 recipientes	108, 142
set de huevera	116
set para cereales/jugo	210
set para zumos	206
sopera para chafing dish	183 - 184
soporte	156
soporte adicional L	148
soporte adicional M	149
soporte buffet	171 - 173
soporte cubiertos servir	190 - 191
soporte de bar	115
soporte para mermelada	113
soporte para palillos	62
soporte para platos o fuentes	211
soporte plato postre	107 - 109, 211 - 212
soporte platos	109, 213
soporte platos alto	217
soporte platos bajo	217
soporte platos postre	109, 213
soporte principal L	148
soporte principal M	148
soporte quemador	189 - 190
soporte quemador urna de café	194
sujeción doble de pared para disp. Cereales	200
sujeción sencilla de pared para disp. cereales	199
tapa con recorte	69, 73
taza de procelana M alta con asa	68
taza de procelana M baja con asa	68
taza de procelana S con asa	68
tenedor bogavante	53
tenedor caracoles	53
tenedor carne	50, 56 - 57
tetera	78 - 80, 82
tubo para hielo	206
urna de café	193
vaso LATTE (UV 6 p.)	67
vaso S (UV 6 p.)	68
vaso té	76
vinagreras	134 - 139, 142

<b>Articolo</b>	<b>Pagina</b>	<b>Articolo</b>	<b>Pagina</b>	<b>Articolo</b>	<b>Pagina</b>
abriscatole	61	dispenser cereali	198 - 199	pinza universale	52
adattatore per piastra		dispenser latte	205	porta formaggio	224
riscaldante	188	dispenser per succhi di frutta	204	porta frutta	213 - 215
alcool solido	190			porta immagini in plexi S	160
alzata per frutta	121, 227	elemento per il ghiaccio	98, 209	porta piattini per dessert	107 - 109, 211 - 213
alzata porta dolci	111 - 113	estensione L	148	porta posante	190 - 191
alzata portadolci	111, 214	estensione M	149	porta rifiuti per tavolo	116
		etagere	158	porta stuzzicadenti	117
<b>base</b>	159, 216			porta stuzzicadenti	
bicchiere da tè	76	forchetta aragosta	53	e contenitore per dolcificante	91, 117, 132, 142
bicchieri LATTE (UV 6 p.)	67	forchetta da antipasto	50, 56	portacarta	131
bicchieri S (UV 6 p.)	68	forchetta per lumache	53	portamenu	131
bowl per punch	93 - 94	forchettone	57	portaoggetti per bacchette	62
bricchetto per il latte	74	formaggiera	143	portapane	119 - 120, 225 - 226
bricchetto per il latte (UV 6 p.)	74	fornello	189 - 190	portapiatti	109, 213
brocca di vetro	155	fornello coffee urn	194	portapostate con stuttura	
brocca per acqua	99	fruittiera	119, 158, 216, 225	ad albero	159
brocca termica a doppia parete	100			portasalatini / olive	114 - 115
		<b>GN interno</b>	186	porta-toast	114
<b>caffettiera</b>	78 - 80, 82	GN interno in porcellana	187	posacenero	117
caffettiera con filtro	78	grattuggia formaggio		posate chafing dish	50, 192
candeliere	122 - 123	con contenitore	51	posate da bistecca	58
candeliere lumino	126			posate da bistecca SOLID	58
caraffa per aceto/olio	135	<b>happy spoon</b>	59	posate servire insalata	50
cavatappi	61			Purargan® C	254
cestino per il pane	119, 225	inserto piatto chafing dish	184	Purargan® forte	254
cestino portavino	93	interno in porcellana	182, 184 - 185	Purargan®-bagno ad	
Chafing Dish	149 - 150, 170 - 171, 176 - 180	interno in vetro	157 - 158, 215	immersione per la pulizia	
				dell'argento	254
<b>chillcup</b>	110	<b>lampa da tavola alta</b>		Purargan®-panno per la cura	
ciotola universale	105, 120, 226	c. paralum	125	dell'argento	254
coffee urn	193	lampa da tavola alta			
colino per tè	77 - 78	con paralume	124 - 125	<b>raccoglibriciole</b>	116
colino per tè con vaschetta		lattiera	79 - 81, 90	ramaiolo	55
raccogliocce	77			recipiente di porcellana	69, 74
colonna per secchio		lavagna S	160	recipiente di vetro	75
spumante	96	legumiera con coperchio	104 - 105	rinfrecavino / spumante	95
coltellino per caviale	59			rinfresca bevanda	98, 209
coltello carne	57	<b>macinasale / macinapepe</b>	133	rinfresca-burro	105 - 107
coltello da bistecca	58	menage	134, 140	rinfresca-caviale	109
coltello da bistecca*	58	ménage per tapenade	108, 142	rinfrescavino	95
coltello formaggio	60	mestolino salsa	54	rinfrescavino / spumante	94 - 95
coltello pane	56				
coltello torta	60	<b>numero tavolo</b>	130 - 131	<b>salsiere</b>	104
contenitore per colino tè	77, 79	numero tavolo in plastica	132	secchiello da ghiaccio	100
contenitore per salsa	158			secchiello da ghiaccio	100 - 101
coperchio adatto per vassoio	154, 218, 224	<b>oliera</b>	134 - 139, 142	segnatavola	129 - 130
				senapiera	143
<b>coperchio con punto aperto</b>		<b>paio bacchette</b>	62	set "CultureCup" completo	67
per cucchiaino	69, 73	pala da torta	59	set "KaffeeKultur" completo	71
copertura	160	piastra riscaldante	150, 188 - 189, 194	set ASIA	141
coppa gelato	110			set bacchette	62
copripiatto con pomolo	102 - 103	piatto	152, 218	set café au lait	71
cremiera	82	piatto da torta	224	set café crème	66, 70
cucchiaini "CultureCup"	69	piatto Gastronorm	153	set café espresso doppio	71
cucchiaini "KaffeeKultur"	60	piatto segnaposto	102	set café latte	70
cucchiaino "4 for you"	60	pinza per aragoste	53	set cappuccino	66
cucchiaino per bowl	54	pinza per ghiaccio	52	set da bicchieri	76
cucchiaino per caviale	59	pinza per lumache	54	set da café espresso	66, 70
cucchiaino per patate	55	pinza per zucchero	53	set girevole per succhi	
cucchiaino per uovo	56, 116	pinza servire insalata	51	di frutta	206
cucchianino per gelato	55	pinza servire per dolci	52	set latte-macchiato	66, 70, 76
cucchianino per gelato XL	61			set lattiera zuccheriera	73, 84 - 89
cucchiaino per pasta	51				

<b>Articolo</b>	<b>Pagina</b>
set per bambini	63
set per bar	115
set per buffet	210 - 211
set per cereali/succhi	210
set portauovo	116
set zuccheriera	85, 90
sfera in porcellana	156 - 157
singolo articolo	
"KaffeeKultur"	72
sottobottiglia	97
spremilimone	77
spuntasigari	118
supporto	156
supporto per confetture	113
supporto per dispenser cereali	199
supporto per dispenser cereali dop.	200
supporto per piatti e coppe	211
supporto piatto alto	217
supporto piatto basso	217
<b>targhetta ad appoggio per numero tavolo</b>	<b>129 - 130</b>
targhetta con aggancio a catenella	194
tassa di porcellana M alta con maniglia	68
tassa di porcellana M bassa con maniglia	68
tassa di porcellana S con maniglia	68
tavoletta per il ghiaccio	155, 217
teiera	78 - 80, 82
telaio	151 - 152, 171 - 173
tubo in acciaio	206
<b>unità base L</b>	<b>148</b>
<b>unità base M</b>	<b>148</b>
<b>vasca per ghiaccio</b>	<b>154 - 155</b>
vaso da fiori	127 - 128
vassoietto tripartito portazucchero	91, 113
vassoio	67, 91 - 92, 114, 135, 152 - 153, 159, 185, 215, 219 - 224
vassoio Gastronorm	221 - 222
vassoio per zucchero	83
versamiele / versalette	83
versavino	93
versazucchero	83
<b>zuccheriera</b>	<b>80 - 81, 83, 90</b>
zuppiera	182 - 183
zuppiera per chafing dish	183 - 184





Showrooms  
Sales offices in Germany

Frankfurt  
Otto-Volger-Straße 5  
65843 Sulzbach  
☎ 0 61 96 / 75 00-07  
Fax 0 61 96 / 74 88 2  
verkaufsbuero.sulzbach@wmf.de

Berlin  
Am Borsigturm 15  
13507 Berlin  
☎ 030 / 496-65 11  
Fax 030 / 496-98 06  
verkaufsbuero.berlin@wmf.de

Hamburg  
Mönckebergstr.13  
20095 Hamburg  
☎ 0 40 / 23 03 21  
Fax 0 40 / 23 68 77 31  
verkaufsbuero.hamburg@wmf.de

Tochtergesellschaften  
Subsidiaries

WMF Nederland B.V.  
Postbus 20604  
1001 NP Amsterdam  
Netherlands

Showroom:  
Gyroscoopweg 82/84  
1042 AX Amsterdam  
Netherlands  
☎ +31 20 480 80 85  
Fax +31 20 480 80 98  
business@wmf.nl

WMF in Österreich GmbH  
Etrichgasse 13  
6020 Innsbruck  
Austria  
☎ +43 512 33 02 - 0  
Fax +43 512 33 02 - 97  
gastro@wmf.at

WMF Schweiz AG  
Bernstraße 90  
8953 Dietikon  
Switzerland  
☎ +41 43 322 93 33  
Fax +41 43 322 93 99  
gastro@wmf.ch

WMF Española, S.A.  
Avda. Llano Castellano, 15  
28034 Madrid/Spain  
☎ +34 91 334 12 15  
Fax +34 91 729 32 22  
hotel@wmf.es

WMF France S.A.R.L.  
13/15 rue Nicolas Ledoux  
94000 Creteil  
France  
☎ +33 1 49 80 80 10  
Fax +33 1 49 80 70 90  
info@wmf.fr

WMF United Kingdom Ltd.  
31 Riverside Way  
Uxbridge  
Middlesex UB8 2YF  
United Kingdom  
☎ +44 1895 816 100  
Fax +44 1895 816 105  
sales@wmf.uk.com

WMF Japan Corp. K.K.  
23-5, Nishishinbashi 3-Chome Minato-ku  
Tokyo 105-0003  
Japan  
☎ +81 3 5408 3301  
☎ +81 3 5408 3302 (hotel)  
Fax +81 3 5408 3311  
info@wmf-japan.co.jp  
wmfj@wmf-japan.co.jp

WMF Shanghai Co. Ltd.  
1101-1102 International  
Capital Plaza  
1318 North SiChuan Road  
Hongkou District  
Shanghai 200086  
P.R. China  
☎ +86 21 5515 5212  
Fax +86 21 5515 5220  
info@wmf-china.com

WMF Hotel  
Eine Marke der proHeq GmbH  
A brand of proHeq GmbH  
Carl-Benz-Straße 10  
D-75217 Birkenfeld, Germany  
☎ +49 (0) 72 31 / 4885 500  
Fax +49 (0) 72 31 / 4885 590  
info@wmf-hotel.de  
www.wmf-hotel.de



WMF Hotel ist nach DIN EN ISO 9001-2008  
zertifiziert und garantiert Ihnen ein Höchstmaß  
an Zuverlässigkeit und Kundenorientierung

WMF Hotel is certified in accordance with DIN EN  
ISO 9001-2008. This guarantees the highest level  
of reliability and customer satisfaction