



- AGRICULTURE
- AIRPORTS
- BUOY & MARINE
- COASTAL

- HYDROLOGY
- INDUSTRIAL & PLC
- INTRINSICALLY SAFE
- IOT

- METEOROLOGY
- OCEANOGRAPHY
- ROAD MANAGEMENT
- POLAR AND WINTER

- SHIPS
- SKI LIFT & SNOW MAKING
- SMART CITIES
- WEATHER STATIONS

Wind speed & wind direction



MeteoWind 2

Anemometer with wind vane. Exceeds **WMO, MEASNET & Class 1** requirements or accuracy for meteorology & wind resource assessment. Very low 4mA power consumption with inrush protection offer an intrinsically safe solution for hazardous environments. Protected oversize bearings offer superb dirt and weather resistance that has been tested to provide **long-term measurement stability & reliability** in dirty & dusty environments.

Serviceable bearing & cups with high dirt resistance

- Serviceability of rotor bearing, anemometer cups and wind vane
- Special double-arm reinforced cup design with over-size bearings offer robustness.
- Highest level of 3 stage lightning, EMC, Surge & ESD protection
- Industry standard RS-485 output
- Simple & robust MODBUS RTU and ASCII communication protocol is user selectable
- Long-term tested dirt resistance in highly dusty environments with salt-spray
- *All models feature a weather proof locking bayonet connector.*

Elliptic cup design offers snow resistance and high accuracy per WMO & MEASNET standards

Dual arm reinforced cup design for all weather reliability

- WMO & MEASNET compliant wind speed and direction.
- 10Hz sampling rate to accurately capture wind gusts.
- Fast response and minimal over-speeding for accurate wind gust measurement.
- Robust two arm reinforced rotor cup design
- Special flat elliptical cups offer superb snow shedding with very good hail resistance
- Exceptional snow shedding and hail resistance due to an all-metal anodized-aluminum body with special fiber reinforced GRP and UV stabilized black dual-arm cup design

Heated anemometer with wind vane 25 Watts of heat for all weather reliability

- 25W built in dual heater distributes heat where it is needed most.
- Heater can be controlled manually from a data logger or automatically based on anemometer temperature only or based on anemometer temperature and wind speed.
- Safe operation from 5V up to a 24V DC power source.
- Heater output of can be controlled by input voltage
- 25W at 24V for high reliability all weather deicing
- 6W at 12V with user selectable automatic or manual control for AWOS/AWS weather stations
- Patented flat elliptic cups offer superb winter snow shedding even without heating.

For applications where WMO accuracy and reliability with lightning protection and all-weather resistance is important

UPGRADE TO INTRINSICALLY SAFE

mechanically strong, 4mA power consumption, inrush protection, triple level lightning, transient, surge, ESD protection.





Measurement standards of anemometer & wind vane				
	Range	Resolution	Accuracy	Sampling rate
Wind speed	0-80 m/s	0.01m/s	< 1% of measured value (0.3 - 50 m/s) or < ±0.2 m/s ±0.05m/s (4-16m/s) with MEASNET CALIBRATION	10Hz @ 3 pulses per revolution
Wind direction	0-360°	1°	2° (no dead-spot)	10Hz
Linearity	R ² > 0.99995 MEASNET/IEC 61400-12-1:2005			
Tilt angle sensitivity	Cosine response, see graph. (Horizontal wind speed measurement)			
Starting wind speed	<0.3m/s			
Default linearity constants (Calibration equation coefficients)	Defaults: Slope = 0.43 m/s Offset = 0.33 m/s ($m/s = 0.43 * freq(Hz) + 0.33$) For MEASNET accuracy without calibration: Slope = 0.4341 m/s Offset = 0.3054 m/s			
Distance constant (Delay distance)	<3m (est.) (per ASTM D 5096-96)			
Electrical specifications of anemometer & wind vane				
Output signal & communication	RS-485 with Modbus RTU & ASCII, (also available: Frequency, 0-10V, 4-20mA, RS232, RS422)			
Supply Voltage	5...24VDC with inrush protection & reverse polarity protection			
Power consumption	4mA (combined wind speed & direction at 10Hz sampling including RS485 communication)			
Lightning & surge protection	per IEC EN 61000-4-5 on both data & power lines, Surge, EFT/Burst, ESD 15kV			
Environmental rating of anemometer & wind vane				
Operating temperature	-40°C to +80°C			
Operating humidity range	0% to 100% RH			
Survival wind speed	>90m/s (324kph, 200mph)			
Connection	Bayonet connector with silicone o-ring			
IP – Protection rating	IP55W (DIN 40050)			
General anemometer & wind vane specifications				
Heater (optional)	25W (1.1A) @ 24VDC (6W @ 12VDC), User selectable manual or automatic heater control			
Weight (mass)	Anemometer = aprox. 300g (without stainless steel mount)			
Dimensions	Anemometer rotor diameter = Ø164mm, Wind vane radius = 136mm, Total height = 320mm			
Patented / Registered	OHIM 002153882-0001, 002153882-0002, 002153882-0003			
Mounting	two M4 screws with supplied holder as pictured below			

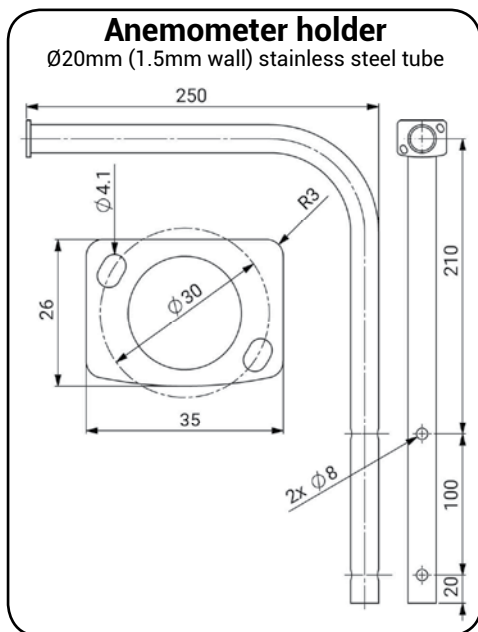

Compact design

Combining of the anemometer and wind vane electronics allows this compact design to shine. Improved levels of reliability are made possible due to the reduction of electrical components. Compact size increases anemometer accuracy and reduces snow buildup for improved winter operations and more effective heater deicing.

Other customer related benefits from this combined wind sensor include:

- Reduction in the number of connectors & wiring for better weather & lightning resistance
- Reduction in mounting hardware and installation time
- Simpler & faster maintenance
- Simpler data logger configuration

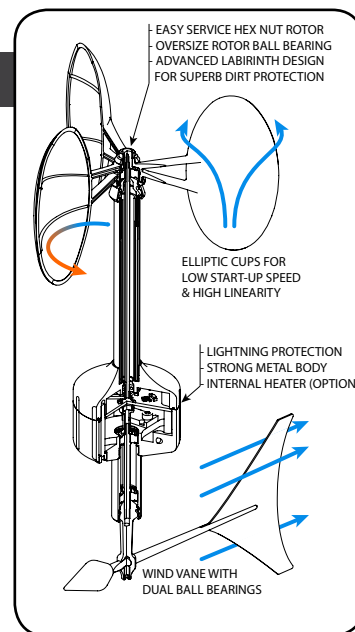

Reach your Gold Standard of measurement with BARANI sensors. ISO:9001 quality.



accredited by the / *akkreditiert durch die***Deutsche Akkreditierungsstelle GmbH**as calibration laboratory in the / *als Kalibrierlaboratorium im***Deutschen Kalibrierdienst**Deutsche
Akkreditierungsstelle
D-K-15140-01-00Calibration certificate
*Kalibrierschein*Calibration mark
Kalibrierzeichen

1721109
D-K-
15140-01-00
04/2017

Object <i>Gegenstand</i>	Combined Wind Sensor
Manufacturer <i>Hersteller</i>	BARANI DESIGN, s.r.o. Slovakia
Type <i>Typ</i>	Elliptic Anemometer 3 / MeteoWind 2
Serial number <i>Fabrikat/Serien-Nr.</i>	-
Customer <i>Auftraggeber</i>	BARANI DESIGN, s.r.o. Slovakia
Order No. <i>Auftragsnummer</i>	Email 2017-03-29, Jeneiova
Project No. <i>Projektnummer</i>	VT170471
Number of pages <i>Anzahl der Seiten</i>	4
Date of Calibration <i>Datum der Kalibrierung</i>	25.04.2017

This calibration certificate documents the traceability to national standards, which realize the units of measurement according to the International System of Units (SI).

The DAkKS is signatory to the multilateral agreements of the European co-operation for Accreditation (EA) and of the International Laboratory Accreditation Cooperation (ILAC) for the mutual recognition of calibration certificates. The user is obliged to have the object recalibrated at appropriate intervals.

Dieser Kalibrierschein dokumentiert die Rückführung auf nationale Normale zur Darstellung der Einheiten in Übereinstimmung mit dem Internationalen Einheitensystem (SI).

Die DAkKS ist Unterzeichner der multilateralen Übereinkommen der European co-operation for Accreditation (EA) und der International Laboratory Accreditation Cooperation (ILAC) zur gegenseitigen Anerkennung der Kalibrierscheine. Für die Einhaltung einer angemessenen Frist zur Wiederholung der Kalibrierung ist der Benutzer verantwortlich.

This calibration certificate may not be reproduced other than in full except with the permission of both the German Accreditation Body and the issuing laboratory. Calibration certificates without signature are not valid. This calibration certificate has been generated electronically.

Dieser Kalibrierschein darf nur vollständig und unverändert weiterverbreitet werden. Auszüge oder Änderungen bedürfen der Genehmigung sowohl der Deutschen Akkreditierungsstelle als auch des ausstellenden Kalibrierlaboratoriums. Kalibrierscheine ohne Unterschrift haben keine Gültigkeit. Dieser Kalibrierschein wurde elektronisch erzeugt.

Date
Datum

23.06.2017

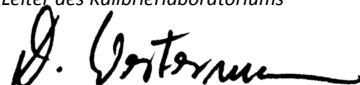
Head of the calibration laboratory
Leiter des Kalibrierlaboratoriums

Dipl. Phys. Dieter Westermann

Person in charge
Bearbeiter

Heiko Westermann, B. Sc.

Calibration object
Kalibriergegenstand

Combined Wind Sensor

Calibration procedure
Kalibrierverfahren

- Deutsche WindGuard Wind Tunnel Services: QM-KL-AK-VA
- Based on following standards:
- MEASNET: Anemometer calibration procedure
 - IEC 61400-12-1: Power performance measurements of electricity producing wind turbines
 - IEC 61400-12-2: Power performance of electricity producing wind turbines based on nacelle anemometry
 - ISO 3966: Measurement of fluid in closed conduits
 - ISO 16622: Meteorology - Sonic anemometers/thermometers

Place of calibration
Ort der Kalibrierung

Windtunnel of Deutsche WindGuard WindTunnel Services GmbH, Varel

Test conditions
Messbedingungen

wind tunnel area	10000 cm ²
anemometer frontal area	200 cm ²
diameter of mounting pipe	34 mm
blockage ratio ¹⁾	0.020 [-]
software version	7.7

¹⁾ Due to the special construction of the test section no blockage correction is necessary.

Ambient conditions
Umgebungsbedingungen

air temperature	25.2 °C ± 0.1 °C
air pressure	1006.7 hPa ± 0.3 hPa
relative air humidity	28.0 % ± 2.0 %

Measurement uncertainty
Messunsicherheit

The expanded uncertainty assigned to the measurement results is obtained by multiplying the standard uncertainty by the coverage factor $k = 2$. It has been determined in accordance with DAkkS-DKD-3. The value of the measurand lies within the assigned range of values with a probability of 95%.
The reference flow speed measurement is traceable to the German NMI (Physikalisch-Technische Bundesanstalt) standard for flow speed. It is realized by using a PTB owned and calibrated Laser Doppler Anemometer (Standard Uncertainty 0.2 %, $k=2$)

Additional remarks
Zusätzliche Anmerkungen

Revision 1.0 (replaces certificate dated 08.06.2017)

Calibration result
Kalibrierergebnis

Sensor out	Tunnel Speed	Uncertainty (k=2)
Hz / 2	m/s	m/s
4.227	3.926	0.050
6.461	5.896	0.051
8.631	7.814	0.050
10.905	9.803	0.051
13.323	11.888	0.052
15.686	13.894	0.052
17.806	15.763	0.052
16.812	14.881	0.052
14.458	12.853	0.051
12.144	10.861	0.051
9.754	8.815	0.051
7.543	6.870	0.050
5.239	4.857	0.050

File: 1721109

Statistical analysis	Slope	0.86825 (m/s)/(Hz/2) ±0.00170 (m/s)/(Hz/2)
	Offset	0.3054 m/s ±0.020 m/s
	Standard error (Y)	0.025 m/s
	Correlation coefficient	0.999979

Remarks The calibrated sensor complies with the demanded linearity of MEASNET



Graphical representation of the result
Grafische Darstellung des Ergebnisses

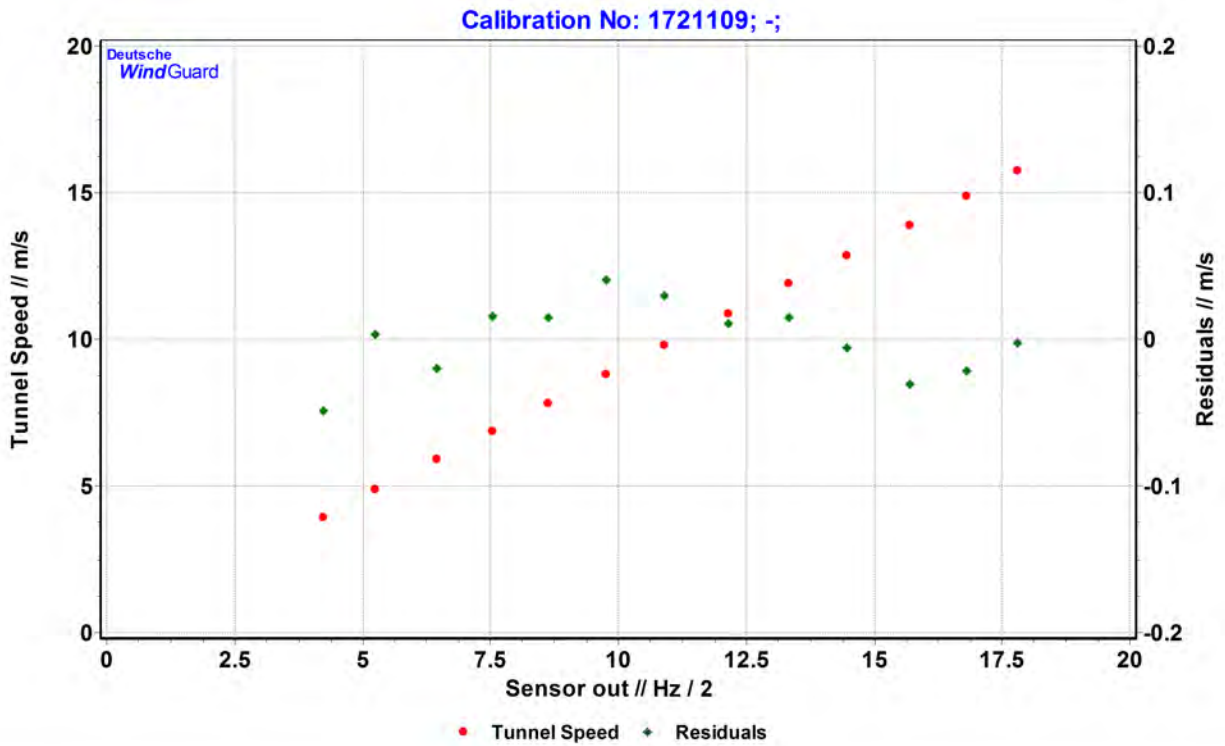

Photo of the measurement setup
Foto des Messaufbaus



Remark: The proportions of the set-up may not be true to scale due to imaging geometry.